



RODAMIENTOS Y COMPONENTES
BEARINGS AND COMPONENTS



CATÁLOGO TÉCNICO GENERAL
GENERAL TECHNICAL CATALOGUE



1.03.15

www.isb-bearing.com



Política ambiental

El presente **Catalogo Tecnico ISB®** ha sido realizado con **material ecologico certificado FSC®**.
El proceso productivo del papel se lleva a cabo respetando las normativas vigentes **DS/EN ISO 14001** e **ISO 9001:2008**.
Las tintas para la impresión son de base vegetal.
Por favor continúe Usted también con su compromiso por la protección del medio ambiente.

Environmental policy

*This **ISB® Technical Catalogue** has been produced with **FSC® 100% certified paper**.
Manufacturing process follows the regulations in force: **DS/EN ISO 14001** and **ISO 9001:2008**.
Inks used are vegetable based.
Please continue your actions in order to protect the environment and recycle properly.*

■ SEDE PRINCIPALE
HEAD OFFICE



■ MAGAZZINO
WAREHOUSE

■ UFFICIO COMMERCIALE
SALES DEPARTMENT

sede ITALIA



ITALCUSCINETTI S.p.A.
forniture industriali
industrial supplies



ITALCUSCINETTI S.p.A. - Via Caponnetto, 15 - 42048 Rubiera (RE) ITALIA
Vendite ITALIA Tel. 0039 0522 621811 - Fax 0039 0522 628926
Export Sales Dept. Tel. 0039 0522 621830 - Fax 0039 0522 626149
Purchasing Dept. Tel. 0039 0522 621880 - Fax 0039 0522 629255
Codice Fiscale e Partita IVA CEE IT 00966080350
R.E.A. C.C.I.A.A. RE 153325 - Capitale Sociale € 1.000.000 i.v.
info@italcuscinetti.it - www.italcuscinetti.it

sede CINA

SHANGHAI ITALCUSCINETTI CO., LTD.

SHANGHAI ITALCUSCINETTI CO., LTD. - No. 89, Lane 85 Qianyun Road
Xujing Town, Qingpu District - Shanghai 201702 (People's Republic of China)
Tel. 0086 21 5988 5302 - Fax 0086 21 5988 5305 - info@italbearings.cn



Cuscinetti e Componenti
Bearings and Components



www.isb-bearing.com



Cuscinetti a rullini
Ruote libere
Componenti per la
movimentazione lineare
Needle bearings
Free wheels
Components for
linear motion

TSC

Supporti
autoallineanti
Self-aligning
bearing units

SKF-FAG

Completo assortimento in
pronta consegna
Big and full assortment of
bearings with prompt delivery

PROGRAMA GENERAL DE VENTAS

GENERAL SALES PROGRAM



RODAMIENTOS Y COMPONENTES *
*BEARINGS AND COMPONENTS **



SOPORTES AUTOALINEANTES *
*SELF-ALIGNING BEARING UNITS **



**RÓTULAS - CABEZAS DE ARTICULACIÓN
- HORQUILLAS ***
*SPHERICAL PLAIN BEARINGS
ROD ENDS - CLEVISSES **



CASQUILLOS *
*BUSHES **



CORONAS GIRATORIAS *
*SLEWING BEARINGS **



**ELECTRICAL MOTORS STANDARD
RODAMIENTOS PARA APLICACIONES
"BAJA RUMOROSIDAD" ***
*BEARINGS FOR "LOW NOISE" APPLICATIONS **

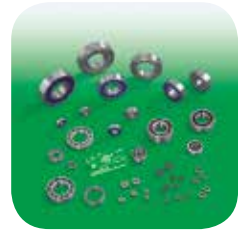

**RODAMIENTOS DE BOLAS
EN MATERIALES POLIMÉRICOS ***
*POLYMERIC BALL BEARINGS **



RODAMIENTOS DE AGUJAS *
*NEEDLE BEARINGS **



RUEDAS LIBRES *
*FREE WHEELS **



**COMPONENTES PARA
SISTEMAS LINEALES ***
*COMPONENTS FOR LINEAR MOTION **



SOPORTES AUTOALINEANTES *
*SELF-ALIGNING BEARING UNITS **



DISPONIBLE UN STOCK AMPLIO Y COMPLETO
DE RODAMIENTOS CON ENTREGA INMEDIATA.
*WIDE AND COMPLETE ASSORTMENT
OF BEARINGS WITH PROMPT DELIVERY.*

RODAMIENTOS SKF - FAG
SKF - FAG BEARINGS





CATÁLOGO TÉCNICO GENERAL
GENERAL TECHNICAL CATALOGUE

Distribuidor / Distributor



PAÍSES DONDE ESTAMOS PRESENTES

COUNTRIES WHERE WE ARE REPRESENTED

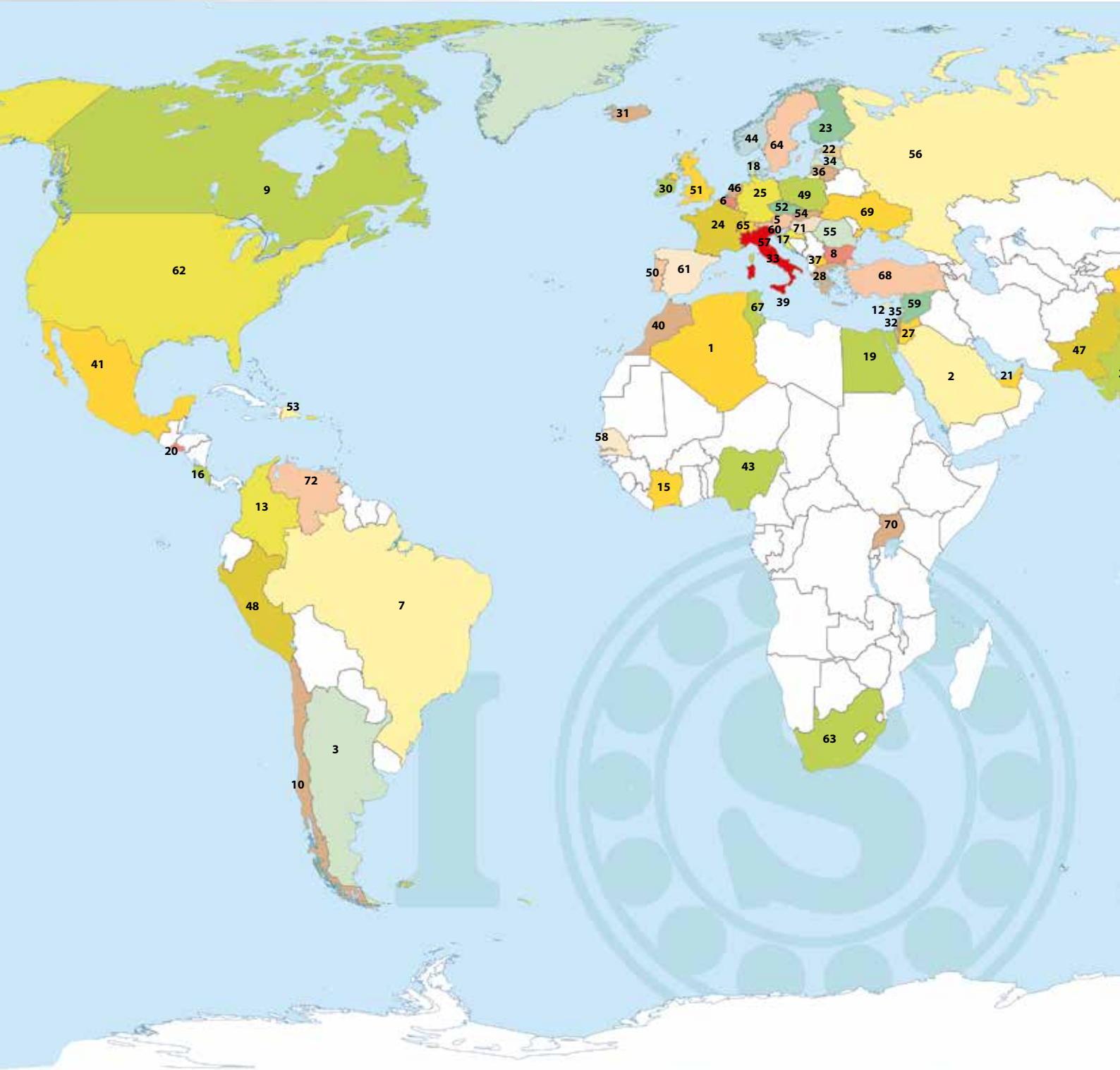

*hora legal (período de marzo a octubre en Italia)

*summer time (from March to October in Italy)

hora solar (-1)

standard time (-1)

para las capitales con el horario indicado en rojo no existe una hora legal

time is indicated in red for capitals with no daylight saving time (DST)



	1 ARGELIA (Argel - 11:00)		ALGERIA
	2 ARABIA SAUDITA (Riyadh - 13:00)		SAUDI ARABIA
	3 ARGENTINA (Buenos Aires - 07:00)		ARGENTINA
	4 AUSTRALIA (Canberra - 20:00)		AUSTRALIA
	5 AUSTRIA (Viena - 12:00)		AUSTRIA
	6 BÉLGICA (Bruselas - 12:00)		BELGIUM
	7 BRASIL (Brasilia - 07:00)		BRAZIL
	8 BULGARIA (Sofia - 13:00)		BULGARIA
	9 CANADA (Ottawa - 06:00)		CANADA
	10 CHILE (Santiago - 06:00)		CHILE
	11 CHINA (Pekín - 18:00)		CHINA
	12 CHIPRE (Nicosia - 13:00)		CYPRUS
	13 COLOMBIA (Bogotá - 05:00)		COLOMBIA
	14 COREA DEL SUR (Seúl - 19:00)		SOUTH KOREA
	15 COSTA DE MARFIL (Abidjan - 10:00)		IVORY COAST
	16 COSTA RICA (San José - 04:00)		COSTA RICA
	17 CROACIA (Zagreb - 12:00)		CROATIA
	18 DINAMARCA (Copenhague - 12:00)		DENMARK
	19 EGIPTO (El Cairo - 13:00)		EGYPT
	20 EL SALVADOR (San Salvador - 04:00)		EL SALVADOR
	21 EMIRADOS ÁRABES UNIDOS (Abu Dhabi - 14:00)		UNITED ARAB EMIRATES
	22 ESTONIA (Tallinn - 13:00)		ESTONIA
	23 FINLANDIA (Helsinki - 13:00)		FINLAND
	24 FRANCIA (París - 12:00)		FRANCE
	25 ALEMANIA (Berlín - 12:00)		GERMANY
	26 JAPÓN (Tokio - 19:00)		JAPAN
	27 JORDANIA (Amman - 13:00)		JORDAN
	28 GRECIA (Atenas - 13:00)		GREECE
	29 INDIA (Nueva Delhi - 15:30)		INDIA
	30 IRLANDA (Dublín - 11:00)		IRELAND
	31 ISLANDIA (Reykjavik - 10:00)		ICELAND
	32 ISRAEL (Jerusalén - 13:00)		ISRAEL
	33 ITALIA (Roma - 12:00)*		ITALY
	34 LETONIA (Riga - 13:00)		LATVIA
	35 LIBANO (Beirut - 13:00)		LEBANON
	36 LITUANIA (Vilnius - 13:00)		LITHUANIA
	37 MACEDONIA (Skopie - 12:00)		MACEDONIA
	38 MALASIA (Kuala Lumpur - 18:00)		MALAYSIA
	39 MALTA (Valletta - 12:00)		MALTA
	40 MARRUECOS (Rabat - 10:00)		MOROCCO
	41 MÉXICO (Ciudad de México - 06:00)		MEXICO
	42 NEPAL (Kathmandú - 15:45)		NEPAL
	43 NIGERIA (Abuja - 11:00)		NIGERIA
	44 NORUEGA (Oslo - 12:00)		NORWAY
	45 NUEVA ZELANDIA (Wellington - 22:00)		NEW ZEALAND
	46 HOLANDA (Ámsterdam - 12:00)		NETHERLANDS
	47 PAQUISTÁN (Islamabad - 16:00)		PAKISTAN
	48 PERÚ (Lima - 05:00)		PERU
	49 POLONIA (Varsovia - 12:00)		POLAND
	50 PORTUGAL (Lisboa - 11:00)		PORTUGAL
	51 REINO UNIDO (Londres - 11:00)		UNITED KINGDOM
	52 REPUB. CHECA (Praga - 12:00)		CZECH REPUBLIC
	53 REPUB. DOMINICANA (Santo Domingo - 06:00)		DOMINICAN REPUBLIC
	54 REPUB. ESLOVACA (Bratislava - 12:00)		SLOVAKIAN REPUBLIC
	55 RUMANÍA (Bucarest - 13:00)		RUMANIA
	56 RUSIA (Moscú - 14:00)		RUSSIA
	57 SAN MARINO (San Marino - 12:00)		SAN MARINO
	58 SENEGAL (Dakar - 10:00)		SENEGAL
	59 SIRIA (Damasco - 13:00)		SYRIA
	60 ESLOVENIA (Liubliana - 12:00)		SLOVENIA
	61 ESPAÑA (Madrid - 12:00)		SPAIN
	62 ESTADOS UNIDOS DE AMÉRICA (Washington - 06:00)		UNITED STATES OF AMERICA
	63 SUDÁFRICA (Pretoria - 12:00)		SOUTH AFRICA
	64 SUECIA (Estocolmo - 12:00)		SWEDEN
	65 SUIZA (Berna - 12:00)		SWITZERLAND
	66 TAIWAN (Taipei - 18:00)		TAIWAN
	67 TUNISIA (Túnez - 11:00)		TUNISIA
	68 TURQUÍA (Ankara - 13:00)		TURKEY
	69 UCRAINA (Kiev - 13:00)		UKRAINE
	70 UGANDA (Kampala - 14:00)		REPUBLIC OF UGANDA
	71 HUNGRÍA (Budapest - 12:00)		HUNGARY
	72 VENEZUELA (Caracas - 06:00)		VENEZUELA

Producción

Production

Todos los productos **ISB®** son fabricados exclusivamente por empresas que cuentan con Sistema de Calidad certificado según las normas UNI EN ISO 9001:2008.

*All products **ISB®** are manufactured exclusively by companies with UNI EN ISO 9001:2008 certified Quality System.*



Control de calidad en Asia

Asia quality control

... una serie de controles adicionales son realizados por Laboratorios externos especializados, dotados de modernos dispositivos.

Laboratorio Control Calidad.



... an additional series of tests are conducted by specialised third party Laboratories using the latest instruments.

Quality Control Laboratory.

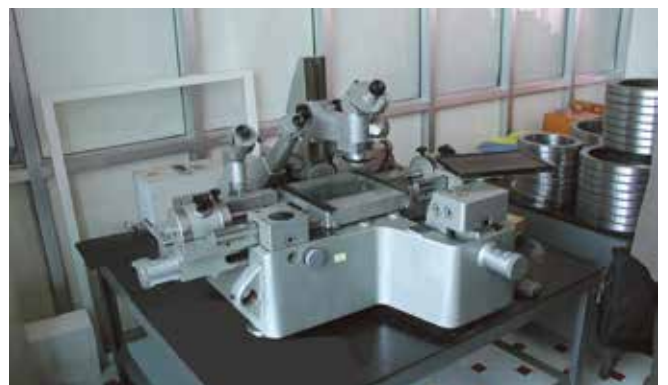
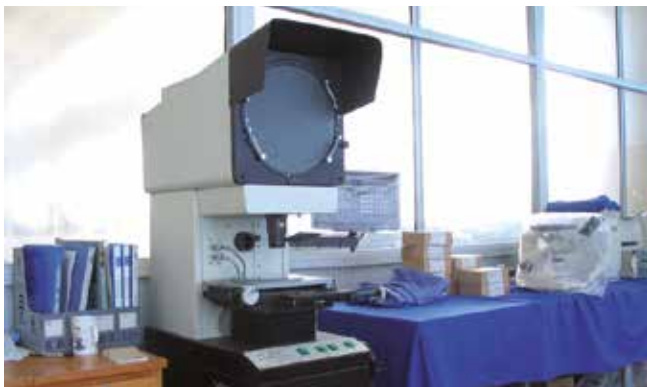

Control de calidad en Italia

Italy quality control

... centro de control de calidad en nuestra sede en ITALIA.

... un staff de Ingenieros técnicos de la Calidad, a su servicio.

... a quality control centre is located in our ITALY headquarters.

... our staff of technical engineers at your service, for Quality.



Documentación calidad

Quality documentations



ISIR N° 002/09

Page n° 1 / 2

14001470
CF 648
20/02/2009

20/02/2009

Bearing 6200 Z

14001470
CF 648
20/02/2009

Bearing 6200 2R5

Caratteristiche controllate Inspected characteristics

Posizione Key	Dimensione nominale Specific nominal dimension Material specification	Unità di misura Unit of measure	Tolleranze Tolerances	Risultati della misurazione Measurement results			Stato Status	Verifica Control
				Ampli 8	Ampli 7	Ampli 9	OK	OK
1	D.e. Φ 30	mm	0/-0.009	29.996	29.999	29.999	-	Ok
2	Foro d.I. Φ 10	mm	0/-0.008	9.999	9.999	9.999	-	Ok
3	Altezza 9	mm	0/-0.120	8.955	8.955	8.955	-	Ok
4	Vdp	mm	0.006	0.003	0.003	0.003	-	Ok
5	Vdmp	mm	0.006	0.007	0.007	0.007	-	Ok
6	VDP	mm	0.007	0.007	0.007	0.007	-	Ok
7	VDmp	mm	0.007	0.007	0.007	0.007	-	Ok
8	Rumorosità	dB	35	35	35	35	-	Ok
9	Vibrazioni	μ m/s	L = 55	55	55	55	-	Ok
10	*	μ m/s	M = 35	35	35	35	-	Ok
11	*	μ m/s	H = 30	30	30	30	-	Ok

Caratteristiche controllate Inspected characteristics

Posizione Key	Dimensione nominale Specific nominal dimension Material specification	Unità di misura Unit of measure	Tolleranze Tolerances	Risultati della misurazione Measurement results			Stato Status	Verifica Control
				Ampli 8	Ampli 7	Ampli 9	OK	OK
1	D.e. Φ 30	mm	0/-0.009	29.995	29.997	29.999	-	Ok
2	Foro d.I. Φ 10	mm	0/-0.008	9.996	9.998	9.999	-	Ok
3	Altezza 9	mm	0/-0.120	8.965	8.965	8.975	-	Ok
4	Vdp	mm	0.006	0.006	0.006	0.006	-	Ok
5	Vdmp	mm	0.006	0.006	0.006	0.006	-	Ok
6	VDP	mm	0.007	0.007	0.007	0.007	-	Ok
7	VDmp	mm	0.007	0.007	0.007	0.007	-	Ok
8	Rumorosità	dB	35	35	35	35	-	Ok
9	Vibrazioni	μ m/s	L = 55	55	55	55	-	Ok
10	*	μ m/s	M = 35	35	35	35	-	Ok
11	*	μ m/s	H = 30	30	30	30	-	Ok

BEARING TESTING REPORT

DATA CONTROLLO 11/02/2009

1 x brand

14001470

CF 648

20/02/2009

Bearing 6200 Z

BEARING TESTING REPORT

DATA CONTROLLO 11/02/2009

1 x brand

14001470

CF 648

20/02/2009

Bearing 6200 2R5

BEARING TESTING REPORT

DATA CONTROLLO 11/02/2009

1 x brand

14001470

CF 648

20/02/2009

Bearing 6200 Z

BEARING TESTING REPORT

DATA CONTROLLO 11/02/2009

1 x brand

14001470

CF 648

20/02/2009

Bearing 6200 2R5

Trazabilidad producto

Product traceability

CÓDIGO - CODE

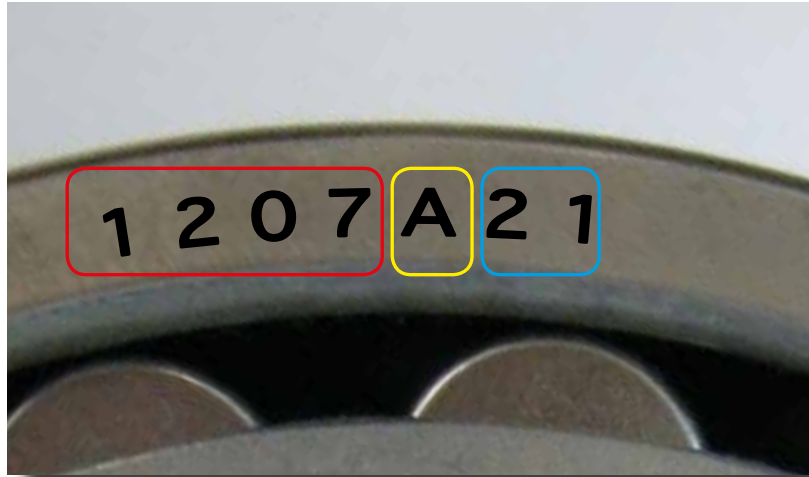

POSICIONAMIENTO 120° - POSITIONING 120°

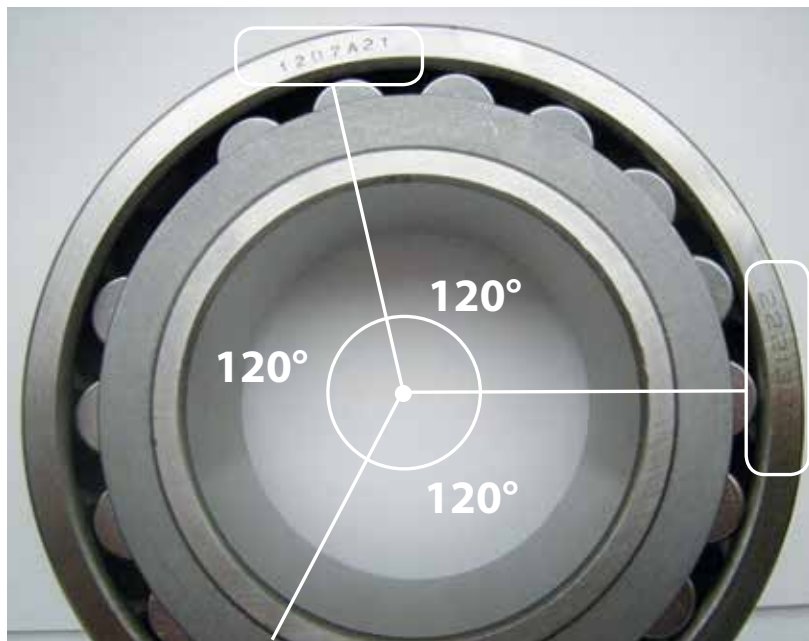

DIMENSIÓN - DIMENSION

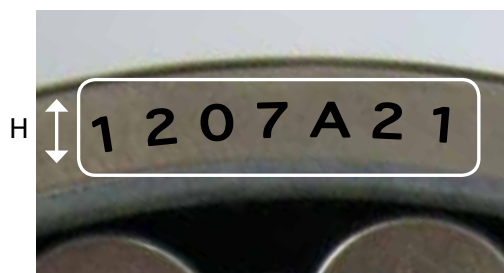

Aplicaciones

Applications

AGRICULTURA
CASA
INDUSTRIA
MÁQUINAS
TIEMPO LIBRE
OFICINAS
VEHÍCULOS

AGRICULTURE
HOME
INDUSTRY
MACHINERIES
FREE TIME
OFFICE
VEHICLES

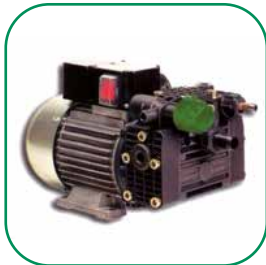

Las numerosas líneas de rodamientos y componentes **ISB®** permiten satisfacer las exigencias en los más diversos sectores de aplicación. La amplia gama y la calidad de los productos permiten garantizar aplicaciones también en condiciones de empleo exigentes. Los rodamientos y componentes **ISB®**, abarcan una producción articulada que incluye todas las tipologías y resulta indicada por lo tanto para satisfacer las más variadas exigencias aplicativas.

*The diverse product lines of **ISB®** bearings and components, make it possible to satisfy the needs of a wide variety of fields of application. The wide range and quality of products is also a guarantee for heavy duty applications. **ISB®** bearings and components are available in versions across-the-board and can meet the requirements of a wide variety of demanding applications.*

Gama productos ISB®

Products range ISB®



**RODAMIENTOS
BEARINGS**

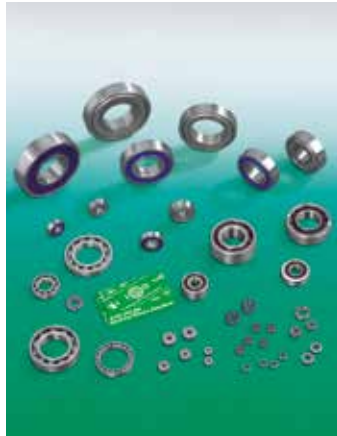

**RODAMIENTOS PARA
APLICACIONES "BAJA
RUMOROSIDAD"
BEARINGS FOR "LOW NOISE"
APPLICATIONS**



**SOPORTES AUTOALINEANTES
SELF-ALIGNING BEARING UNITS**



**RÓTULAS ESFÉRICAS
CABEZAS DE RÓTULAS
HORQUILLAS
SPHERICAL PLAIN BEARINGS
ROD ENDS - CLEVISES**



**CASQUILLOS
BUSHES**



**RODAMIENTOS DE GRANDES
DIMENSIONES
LARGE BEARINGS**



**CORONAS DE GIRO
SLEWING BEARINGS**



**RODAMIENTOS DE BOLAS EN
MATERIALES POLIMÉRICOS
POLYMERIC BALL BEARINGS**



**RODAMIENTOS BONDERIZADOS
PARA ALTAS TEMPERATURAS
BONDERIZED BEARINGS FOR
HIGH TEMPERATURES**



**BOLAS PORTANTES
BOLAS DE PRECISIÓN
RODILLOS Y AGUJAS
DE PRECISIÓN
BALL TRANSFER UNITS
PRECISION BALLS
PRECISION ROLLERS
AND NEEDLES**



**RETENES METÁLICOS
PARA RODAMIENTOS
METALLIC SEALS FOR
BEARINGS**



**PRODUCTOS DE ACERO
INOXIDABLE
STAINLESS STEEL PRODUCTS**

La gama productos ISB® está en continuo desarrollo y en breve, está prevista la ampliación con ulteriores productos.

The ISB® range is continuously in evolution and shortly will be widened by the addition of new items.



ÍNDICE

ISB® MARCA SINÓNIMO DE CALIDAD	4
SISTEMA DE CODIFICACIÓN DE LOS RODAMIENTOS	4
SERIE CONSTRUCTIVA	4
ELECCIÓN DEL RODAMIENTO	7
ELECCIÓN DE LA DIMENSIÓN DEL RODAMIENTO	7
COEFICIENTE DE CARGA DINÁMICA DE REFERENCIA	7
COEFICIENTE DE CARGA ESTÁTICA	7
DURABILIDAD DE LOS RODAMIENTOS	8
DURABILIDAD CON FATIGA NOMINAL	8
LÍMITE DE VELOCIDAD	12
CASOS ESPECIALES. BAJA VELOCIDAD	12
CONDICIONES ESTACIONARIAS	12
TOLERANCIAS DE LOS RODAMIENTOS	12
SÍMBOLOS	13
TABLAS TOLERANCIAS DE LOS RODAMIENTOS	14
JUEGO RADIAL DE LOS RODAMIENTOS DE BOLAS Y DE RODILLOS	18
TABLAS JUEGO RODAMIENTOS	18
TABLAS DIMENSIÓN DE LOS RACORES (BISEL)	21
MATERIALES UTILIZADOS PARA LA FABRICACIÓN DE LOS RODAMIENTOS	23
MATERIAL USADO PARA LA JAULA	23
TRATAMIENTO TÉRMICO	23
TABLA COMPOSICIÓN QUÍMICA DEL ACERO PARA RODAMIENTOS	23
LUBRICACIÓN DE LOS RODAMIENTOS	24
GRASAS UTILIZADAS	25
PAQUETES - EMBALAJES	26
SUFIJOS DE LOS RODAMIENTOS	27

INDEX

ISB® IS A TRADEMARK WHICH IDENTIFIES QUALITY	4
CODING SYSTEM OF THE BEARINGS	4
BEARING TYPE	4
CHOICE OF A BEARING	7
SELECTION OF BEARING SIZE	7
BASIC LOAD RATINGS	7
STATIC LOAD RATING BEARINGS	7
BEARING LIFE	8
BASIC RATING LIFE	8
SPEED LIMIT	12
SPECIAL CASES. LOW SPEED	12
STATIONARY CONDITION	12
BEARING TOLERANCES	12
SYMBOLS	13
TOLLERANCE TABLES OF BEARINGS	14
RADIAL CLEARANCE OF BALL AND ROLLER BEARINGS	18
CLEARANCE TABLES OF BEARINGS	18
MOUNTING CHAMFER DIMENSION TOLERANCES	21
MATERIALS USED DURING THE CONSTRUCTION OF BEARINGS	23
CAGE MATERIALS	23
HEAT TREATMENT	23
CHEMICAL CONTENT OF BEARING STEEL TABLE	23
BEARING LUBRICATION	24
GREASE USED	25
PACKING	26
BEARINGS SUFFIX	27

Índice productos

Products index

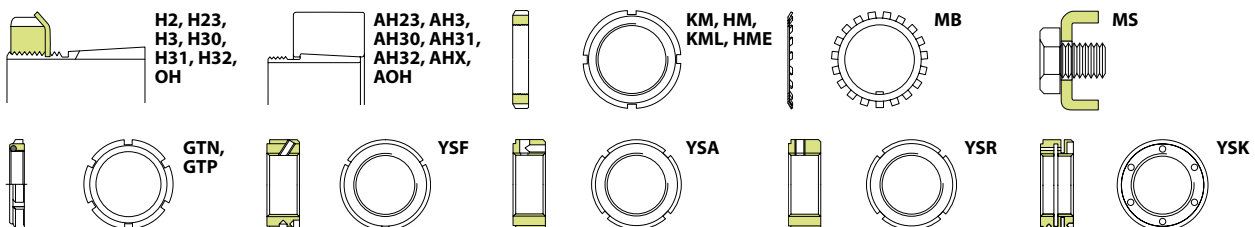
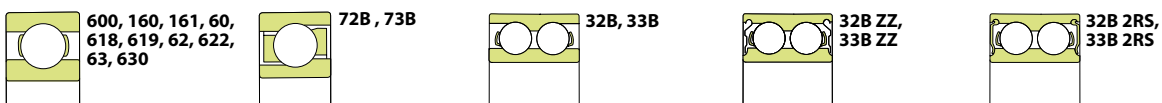
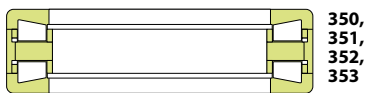
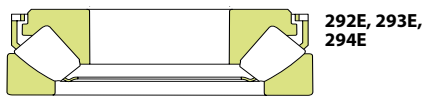
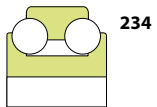
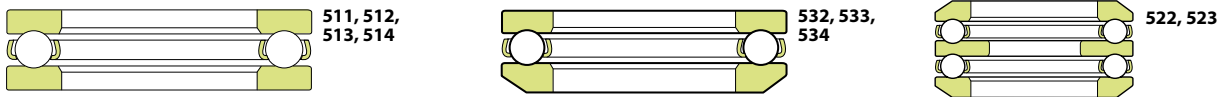
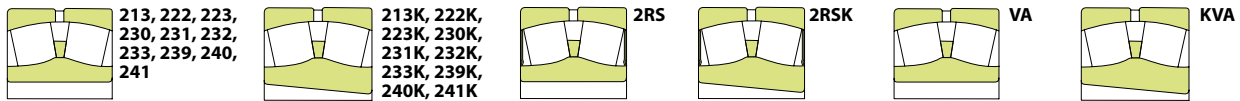
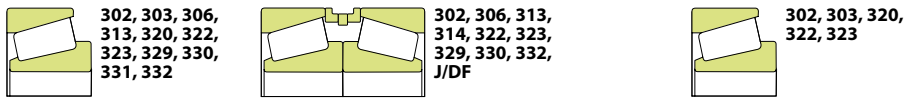
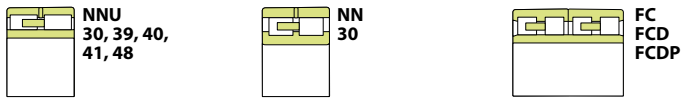
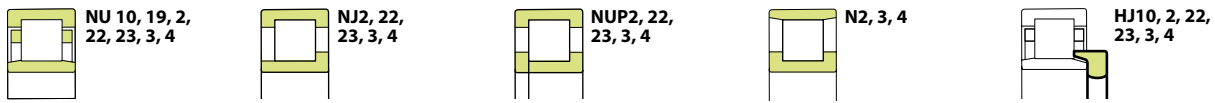
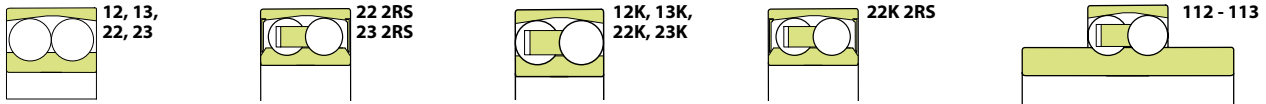
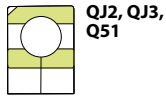
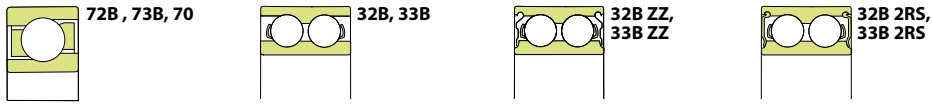
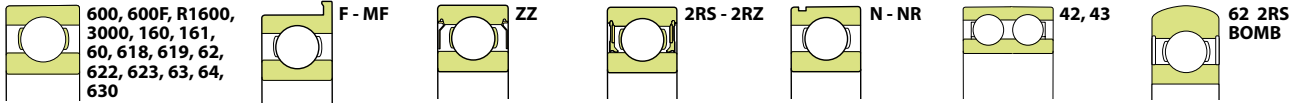

Rodamientos rígidos de bolas <i>Radial deep groove ball bearings</i>	pag. 29
Rodamientos de bolas de contacto angular <i>Angular contact ball bearings</i>	pag. 85
Rodamientos de bolas con cuatro puntos de contacto <i>Four-point contact ball bearings</i>	pag. 99
Rodamientos de bolas a rótula <i>Self-aligning ball bearings</i>	pag. 105
Rodamientos con hilera simple de rodillos cilíndricos <i>Cylindrical roller bearings, single row</i>	pag. 117
Rodamientos de dos/cuatro hileras de rodillos cilíndricos <i>Cylindrical roller bearings, double/four row</i>	pag. 135
Rodamientos de rodillos cónicos, serie métricas y en pulgadas <i>Tapered roller bearings, metric and inches series</i>	pag. 153
Rodamientos de rodillos a rótula <i>Self-aligning roller bearings</i>	pag. 179
Rodamientos axiales de bolas <i>Thrust ball bearings</i>	pag. 207
Rodamientos axiales de contacto angular de bolas, de doble efecto, de alta precisión <i>Angular contact thrust ball bearing, double direction, high-precision</i>	pag. 221
Rodamientos axiales de rodillos a rótula <i>Self-aligning thrust roller bearings</i>	pag. 225
Rodamientos axiales de rodillos cónicos, de doble efecto <i>Tapered roller thrust bearing, double direction</i>	pag. 231
Rodamientos para bombas de agua <i>Water pump bearings</i>	pag. 235
Rodamientos para aplicaciones "baja rumorosidad" <i>Bearings for "low noise" applications</i>	pag. 239
Manguitos y accesorios <i>Sleeves and accessories</i>	pag. 265

ISB® MARCA SINÓNIMO DE CALIDAD

Una marca creada por un pool de fabricantes utilizando elevado knowhow técnico y una maquinaria de avanzada tecnología. La producción abarca todo el sector de los rodamientos estándares; para rodamientos con características técnicas y constructivas particulares está a disposición del cliente una oficina técnica capaz de resolver los problemas inherentes al diseño y a la utilización. Presentamos el programa completo de la producción de los rodamientos estándares ISB®. Este catálogo tiene la función de ayudar y acompañar a los proyectistas de máquinas y equipos, suministrándoles un válido aporte en la búsqueda de las soluciones ideales de empleo de los rodamientos e ilustrar las características técnicas, dimensionales, aplicativas y cualitativas de los rodamientos. La primera parte del catálogo ilustra las características técnicas de todas las series de rodamientos, con las tolerancias dimensionales, el juego de ejecución, la lubricación y otras informaciones técnicas necesarias para la elección del tipo de rodamiento a utilizar. La segunda parte del catálogo incluye las tablas de los rodamientos. En estas tablas los rodamientos están clasificados conforme al tipo de construcción y el diámetro del orificio. Todas las características técnicas constructivas están estandarizadas de conformidad con las normas ISO para suministrar así un producto intercambiable, constante en el tiempo. **Todos los productos ISB® están fabricados de conformidad con la normativa RoHS.**

SISTEMA DE CODIFICACIÓN DE LOS RODAMIENTOS

- El plan general de los rodamientos envolventes métricos está establecido en la norma ISO 15:1998 (excluidos los rodamientos rodillos cónicos);
- los rodamientos radiales métricos de rodillos cónicos están establecidos en la norma ISO 355:1977;
- los rodamientos axiales métricos están establecidos en la norma ISO 104:2002;
- para otras series se adoptan las siglas "europeas".

La sigla de identificación del rodamiento está formada por una serie de letras y de números, todos con un significado preciso y está dividida en tres partes que la identifican, de izquierda a derecha:

- la primera la serie constructiva;
- la segunda la serie dimensional;
- la tercera el diámetro del orificio.

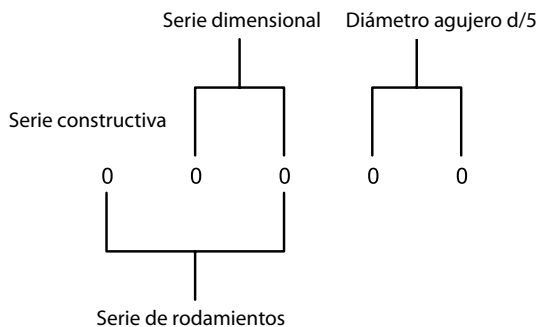

La primera parte de la sigla caracteriza la forma constructiva. Esta parte está siempre indicada en forma numérica, a excepción de los rodamientos de rodillos cilíndricos y para aquellos de bolas con anillo desmontable.

SERIE CONSTRUCTIVA

- | | |
|---|--|
| 0 | Rodamientos de bolas de contacto angular |
| 1 | Rodamientos orientables de bolas |
| 2 | Rodamientos orientables de rodillos, rodamientos axiales orientables de rodillos |

ISB IS A TRADEMARK WHICH IDENTIFIES QUALITY

A brand elaborated by a group of producers using very advanced technical know-how and highest technology machineries. Its production involves all standard bearings schedules; for special technical or constructive requirements a staff of competent technicians works to satisfy every problem about design and utilisation. We are introducing the complete program of basic ISB® bearings production. The purpose of this catalogue is to create a kind of real help for machineries' and equipments' designers: a valid contribution to the research of the best bearings' application; a clear elucidation for technical, dimensional, qualitative and applicative characteristics. The first part of it shows the technical details of every bearing, such as dimensional tolerances, radial clearance, lubrication and some other informations concerning the choice and the type of bearing to use. The second part of it, instead, is dedicated to bearings tables. In these tables all bearings are classified with regard to kind of construction and diameter of bore. All technical constructive characteristics have been determined in accordance with national standard of ISO in order to provide an interchangeable product, steady during the years and of high quality.

All ISB® products are constructed according to RoHS normatives.

CODING SYSTEM OF THE BEARINGS

- The general schedule for metric rolling bearings is established by standard ISO 15:1998 (excluding tapered roller bearings).
- Metric radial tapered roller bearings are established by standard ISO 355:1977.
- Metric thrust bearings are established by standard ISO 104:2002.
- "European" initials are used for other series.

The identification initials of the bearing comprise a series of letters and numbers, all of which have an exact meaning and they are split up into three distinguishing parts, starting from left to right:

- the first is the bearing type;
- the second is the dimensional series;
- the third is the diameter of the bore.

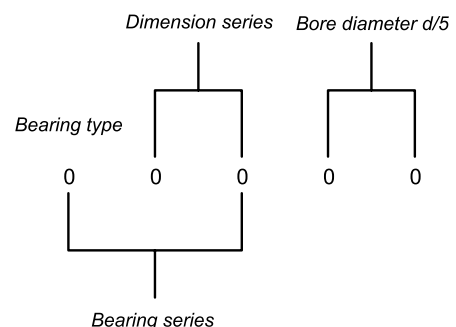

The first part of the initials characterizes the constructional shape. This part is always indicated numerically, with the exception of cylindrical roller bearings and those with balls with removable ring.

BEARING TYPE

- | | |
|---|---|
| 0 | Double row angular contact ball bearing |
| 1 | Self aligning ball bearing |
| 2 | Self aligning roller bearing and aligning roller thrust bearing |

- 3 Rodamientos de rodillos cónicos
- 4 Rodamientos radiales de dos hileras de bolas
- 5 Rodamientos axiales de bolas
- 6 Rodamientos radiales de una hilera de bolas
- 7 Rodamientos de contacto angular de bolas de una hilera de bolas
- 8 Rodamientos axiales de rodillos cilíndricos
- N Rodamientos de rodillos cilíndricos
Una o más letras después "N" como NJ, NU, NUP, la sigla identifica una subfamilia de los rodamientos de rodillos cilíndricos
- QJ Rodamientos con cuatro puntos de contacto

- 3 *Tapered roller bearing*
- 4 *Double row deep groove ball bearing*
- 5 *Thrust ball bearing*
- 6 *Deep groove ball bearing*
- 7 *Angular contact ball bearing*
- 8 *Cylindrical roller thrust bearing*
- N *Cylindrical roller bearing*
If there are one or more letters followed "N" such as NJ, NU, NUP, the code will stand for rib types of bearings
- QJ *Four point contact ball bearing*

La segunda parte de la serie constituye la serie dimensional: se identifican las otras dimensiones del rodamiento, precisamente el diámetro externo y el ancho, expuestos en el diámetro del orificio. Podemos tener, con el mismo orificio y diámetro externo, diversos anchos.

Se distinguen por lo tanto una serie de diámetros y una serie de los anchos.

The second part of the initials represents the dimensional series: the other dimensions of the bearing are identified, namely the outside diameter and the width, in relation to the diameter of the bore. There may be different widths for the same bore and outside diameter.

A series of diameters and a series of widths are therefore distinguished.

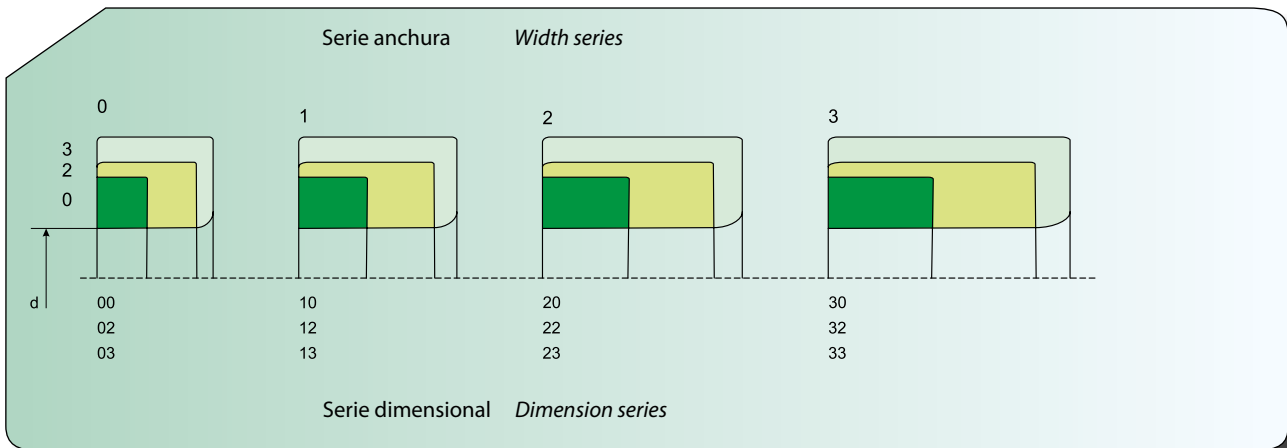

Tanto las series de los diámetros como también la de los anchos, se indican con números internos de una cifra; ambos números forman precisamente la serie dimensional. De izquierda a derecha, el primer número indica las series de los largos, el segundo la de los diámetros. Su combinación se denomina Serie Dimensional y precede el código del diámetro del orificio. Cuando un rodamiento prevé una sola serie de anchos, el número indicativo de la misma no se escribe. El símbolo de la Serie Dimensional estará compuesto sólo por la cifra que caracteriza la serie de los diámetros.

The series of the diameters and that of the widths are both indicated with whole single-figure numbers; these two numbers do indeed form the dimensional series. Starting from left to right, the first number indicates the series of widths and the second the series of diameters. Their combination is called Dimensional Series and comes before the code of the bore diameter. When a bearing has just one series of widths, the relevant indicative number is not written. The symbol of the Dimensional Series will just comprise the figure that characterizes the series of diameters.

La tercera parte define el diámetro del orificio y está compuesto por dos cifras según la siguiente codificación:

- 00 = orificio Ø 10 mm
- 01 = orificio Ø 12 mm
- 02 = orificio Ø 15 mm
- 03 = orificio Ø 17 mm
- 04 = orificio Ø 20 mm (es decir 20 : 5 = 04)
- 05 = orificio Ø 25 mm (es decir 25 : 5 = 05)
- ... hasta:
- 96 = orificio Ø 480 mm (es decir 480 : 5 = 96)

The third part defines the diameter of the bore and consists of two figures according to the following coding system:

- 00 = bore Ø 10 mm
- 01 = bore Ø 12 mm
- 02 = bore Ø 15 mm
- 03 = bore Ø 17 mm
- 04 = bore Ø 20 mm (20 : 5 = 04)
- 05 = bore Ø 25 mm (25 : 5 = 05)
- ... up to:
- 96 = bore Ø 480 mm (480 : 5 = 96)

Para diámetros de orificio de 500 mm incluido y en adelante, después de la parte de la sigla que indica la Serie Dimensional se pone una barra (/) a la cual sigue el diámetro del orificio expresado en milímetros. Ej: 62/500. En el ámbito de una determinada serie

For bore diameters from 500 mm inclusive and larger, after the part of the initials that indicates the Dimensional Series, there will be a slash (/), followed by the diameter of the bore in millimetres. Example: 62/500. For a certain series of be-

de rodamientos las primeras dos partes de la sigla no cambian, mientras es invariable la última parte, es decir aquella que codifica el diámetro del orificio. Esta parte invariable de la sigla, compuesta por forma constructiva y por serie dimensional, generalmente se denomina "serie de rodamientos".

arings, the first two parts of the initials remain the same, while the last part changes, in other words the part that codifies the diameter of the bore. This invariable part of the initials, made up of constructional shape and dimensional series, is normally called "series of bearings".

Serie de rodamientos
Bearing series code

Tipo de rodamiento <i>Bearing type</i>	Serie derodamiento <i>Bearing series code</i>	Serie constructiva <i>Type of bearing</i>	Serie dimensional <i>Dimensional series code</i>
	618	6	18
	619	6	19
Rodamientos radiales de una hilera de bolas <i>Single row deep groove ball bearing</i>	160	6	(0)0
	60	6	(1)0
	62	6	(0)2
	63	6	(0)3
	64	6	(0)4
Rodamientos radiales de dos hileras de bolas <i>Double row deep ball bearings (with filling slot)</i>	42	4	(2)2
	44	4	(2)3
	719	7	19
Cojinetes de contacto angular de una hilera de bolas <i>Single row angular contact ball bearings</i>	70	7	(1)0
	72	7	(0)2
	73	7	(0)3
	74	7	(0)4
Rodamientos de contacto angular de dos hileras de bolas <i>Double row angular contact ball bearing (with filling slot)</i>	32	(0)	32
	33	(0)	33
Rodamientos con cuatro puntos de contacto <i>Four point contact ball bearing</i>	QJ2	QJ1	(0)2
	QJ3	QJ1	(0)3
	12	1	(0)2
Rodamientos orientables de bolas <i>Self aligning ball bearing</i>	22	(1)	22
	13	1	(0)
	23	(1)	23
	NU10	NU	10
	NU2	NU	(0)2
Rodamientos de una hilera de rodillos cilíndricos <i>Single-row cylindrical roller bearing</i>	NU22	NU	22
	NU32	NU	32
	NU3	NU	(0)3
	NU23	NU	23
	NU4	NU	(0)4
	329	3	29
	320	3	20
	330	3	30
	331	3	31
Rodamientos de rodillos cónicos <i>Tapered roller bearing</i>	302	3	02
	322	3	22
	332	3	32
	303	3	03
	313	3	13
	323	3	23
	239	2	39
	230	2	30
	240	2	40
Rodamientos orientables de rodillos <i>Self aligning roller thrust bearing</i>	231	2	31
	241	2	41
	222	2	22
	232	2	32
	213	2	03
	223	2	23
	511	5	11
	512	5	12
Rodamientos axiales de bolas <i>Single direction flat housing washer thrust ball bearing</i>	513	5	13
	514	5	14
	532	5	32
	533	5	33
	534	5	34
	522	5	22
Rodamientos axiales de bolas de doble efecto <i>Double direction flat seat housing washer thrust ball bearing</i>	523	5	23
	524	5	24
	292	2	92
Rodamientos axiales orientables de rodillos <i>Thrust cylindrical roller bearing</i>	293	2	93
	294	2	94

1 - Los números entre paréntesis no deben ser expuestos en el código de la serie de rodamientos
2 - Los rodamientos de rodillos cilíndricos incluyen la serie NJ, NUP, N, NF y NU

1 - Width series codeshower in bracket will be default in bearings series code
2 - Cylindrical roller bearing includes NJ, NUP, N, NF, and NU type

ELECCIÓN DEL RODAMIENTO

La elección del rodamiento está dada principalmente por las características de dimensión y de carga a la cual está sujeto el rodamiento. Las dimensiones y la carga están muchas veces vinculadas al proyecto de la máquina en su conjunto y por lo tanto en muchos casos la elección está limitada a muy pocas tipologías. No existen reglas o tablas precisas, pero generalmente el rodamiento de bolas soporta velocidades elevadas y cargas reducidas, mientras que el rodamiento de rodillos soporta cargas más elevadas pero velocidades inferiores.

Los límites de velocidad de un rodamiento están determinados por la temperatura de funcionamiento. En la elección del rodamiento es importante conocer y considerar los siguientes parámetros:

- exigencias del servicio;
- exigencias de durabilidad de la máquina;
- límites dimensionales del rodamiento;
- factores negativos (vibraciones, golpes, calor, suciedad, ruido aceptable, etc).

ELECCIÓN DE LA DIMENSIÓN DE LOS RODAMIENTOS

Las dimensiones de un rodamiento se eligen considerando las condiciones de carga a las cuales estarán sujetos, la durabilidad nominal de servicio y los prescritos parámetros de seguridad de servicio.

COEFICIENTE DE CARGA DINÁMICA DE REFERENCIA

Para calcular la dimensión de los rodamientos se adopta el coeficiente de clasificación de la carga dinámica de referencia C . Dicho parámetro expresa la carga máxima admisible del rodamiento idóneo para suministrar una durabilidad a la fatiga normal equivalente a 1.000.000 de giros. Los coeficientes de carga dinámica de referencia de los rodamientos **ISB**[®] han sido determinados de conformidad con las normas ISO 281. Teniendo en cuenta los coeficientes de carga dinámica de referencia se calcula el tiempo de servicio necesario para la aparición de signos de fatiga de los materiales, determinando sobre dicha base la durabilidad teórica. En caso de bajas velocidades de rodamiento, de reducidos movimientos oscilantes o en las aplicaciones estacionarias, se tiene en cuenta el coeficiente de carga estática de referencia C_0 . El coeficiente de carga estática de referencia se define como la carga que se verifica en el rodamiento estacionario. Corresponde a un esfuerzo de contacto calculada entre el cuerpo envolvente mayormente cargado y la pista de rodamiento, equivalente a:

- 4600 N/mm² para los rodamientos radiales orientables de bolas.
- 4200 N/mm² para los otros rodamientos de bolas.
- 4.000 N/mm² para todos los rodamientos de rodillos.

Dicho esfuerzo induce a una deformación permanente del cuerpo y del aro de rodadura, equivalente a aproximadamente 1/10000 (0,0001 dw) del diámetro del cuerpo. Las cargas son de tipo simple y radiales, para los rodamientos radiales, de tipo simple y axiales, para los rodamientos axiales.

COEFICIENTE DE CARGA ESTÁTICA

Cuando el rodamiento es estacionario o está sujeto a rotaciones u oscilaciones particularmente lentas (inferiores a 10 rpm), el coeficiente de carga estática no se determinará en función de la fatiga del material, sino en base a la deformación permanente inducida en el lugar del punto de contacto entre el cuerpo y el aro

CHOICE OF A BEARING

Loads and dimensions are the most important factors during the choice of a bearing. These two components are, in the majority of cases, bound to the machinery's project: the choice is therefore restricted to limited cases. Rules or exact tables do not exist usually a ball bearing bears high speeds and low loads, whereas a roller bearing stands lower speeds and higher loads.

Speed limits of a bearing are determined by working temperature. During the choice of it, the following rules have to be followed:

- Gravity of operation
- Machinery's duration
- Encumbrance limit of the bearing
- Negative factors, such as: vibration, collision, heat, dirt, acceptable noise and so on.

SELECTION OF BEARING SIZE.

The size of a bearing is selected by considering different factors, such as its supposed operational life, loads to which it is subjected and prescribed operating safety.

BASIC LOAD RATINGS

*To calculate bearings dimensions, the basic dynamic load rating "C" is used; this factor expresses the admissible load suitable to give a basic rating life up to 1.000.000 revolutions. Basic dynamic and static loads rating for **ISB**[®] bearings have been determined in accordance with standard ISO 281. Considering the basic dynamic load rating, is calculated the service time until the fatigue of the materials appears, determining in this way the calculated rating life. In the case of low speeds, low oscillating movements or stationary applications, "C₀" basic static load rating is considered.*

The basic static load rating is defined as the load acting on the stationary bearing. It corresponds to a calculated contact stress between the most heavily loaded rolling elements and the raceway of:

- 4600 N/mm² for self-aligning ball bearings.
- 4200 N/mm² for all other ball bearings.
- 4000 N/mm² for all roller bearings.

This stress produces a permanent deformation of both rolling elements and raceway, deformation which is about 1/10000 (0,0001 dw) of the rolling element diameter. Loads are pure radial for radial bearings and pure axial for thrust bearings.

STATIC LOAD RATING BEARINGS

When the bearing is stationary or rotates at very slow movements or speeds (lower than 10 r/min), basic static load is not determined by the material fatigue but by permanent deformation caused at the rolling elements and the raceway contact.

de rodadura. Esto es válido también para los rodamientos sujetos a grandes cargas de choque que se verifiquen en el curso de una fracción de giro. En general, el valor de carga podrá aumentar hasta equivaler el coeficiente de carga estática C_0 sin alterar las características operativas del rodamiento. Se deberá convertir en carga estática equivalente la carga estática combinada (carga radial y axial incidentes simultáneamente). Esto se define como la carga (radial para los rodamientos radiales y axial para los rodamientos axiales) que, si aplicada, causaría en el rodamiento la misma deformación permanente inducible por reales condiciones de carga.

La carga estática equivalente está dada por la fórmula:

$$P_0 = X_0 F_r + Y_0 F_a$$

donde:

- P_0 consiste en la carga estática equivalente, expresada en N;
- F_r representa la componente radial de la carga estática de entidad mayor, expresada en N;
- F_a representa la componente axial de la carga estática de entidad mayor, expresada en N;
- X_0 representa el factor de carga radial;
- Y_0 representa el factor de carga axial.

DURABILIDAD DE LOS RODAMIENTOS

La durabilidad de los rodamientos se define como el número de giros, o de horas de funcionamiento, que el rodamiento es capaz de soportar antes que aparezcan los primeros signos de fatiga en uno de sus anillos, o en el aro de rodadura o en los elementos envolventes. Cuando se desee tener en cuenta sólo la fatiga en las superficies de trabajo del rodamiento, se deberán respetar las siguientes condiciones:

- Las fuerzas y las velocidades que se consideren para la evaluación del rodamiento deberán corresponder a las que se verifican a las reales condiciones de servicio.
- Durante todo el período de servicio deberá garantizarse una adecuada lubricación.
- La experiencia demuestra que la razón por la que ceden muchos rodamientos se atribuye a causas diversas a la fatiga, como por ejemplo: elección de un tipo incorrecto de rodamiento, defectos de funcionamiento o de lubricación, presencia de partículas extrañas en el rodamiento u otras causas.

DURACIÓN CON FATIGA NOMINAL

La durabilidad con fatiga normal de un rodamiento o de un grupo de rodamientos idénticos y operantes a idénticas condiciones de servicio, consiste en la durabilidad de servicio equivalente al menos a un grado de fiabilidad del 90%. La durabilidad media de un grupo de rodamientos es muy superior a la durabilidad nominal. La durabilidad a la fatiga nominal se expresa con L_{10} (millones de giros) o L_{10h} (horas de ejercicio). El valor L_{10} podrá calcularse con la ecuación:

$$L_{10} = (C/P)^p$$

donde:

- L_{10} correspondiente a la durabilidad con fatiga nominal, expresada en millones de giros;
- C correspondiente a la carga dinámica del rodamiento, expresada en N;
- P correspondiente a la carga dinámica equivalente, en el rodamiento expresada en N;
- p correspondiente al exponente de durabilidad, de la ecuación, con los siguientes valores:
- $P=3$ para los rodamientos de bolas.
- $P=10/3$ para los rodamientos de rodillos

The same rule is used for rotating bearings standing heavy shock loads which act during a fraction of their revolution. Generally, the value of the load may increase up to the value of the basic static load C_0 , without altering the bearing operation properties. Combined static load (radial and axial load acting together on bearing) must be converted in equivalent static bearing load.

This is defined as the load (radial for radial bearings and axial for thrust bearings), which if applied would cause the same permanent deformation as the real load operative upon the bearing:

$$P_0 = X_0 F_r + Y_0 F_a$$

where:

- P_0 is the equivalent static bearing load, N;
- F_r is the radial component of the heaviest static load, N;
- F_a is the axial component of the heaviest static load, N;
- X_0 is the radial load factor of the bearing;
- Y_0 is the axial load factor of the bearing.

BEARING LIFE

The life of a bearing can be considered as the number of the revolutions or the number of operating hours, that the bearing is able to endure before the first sign of fatigue appears on one of its ring, on the raceway, on the rolling elements. If we want to consider only the fatigue on the bearing operating surfaces, the following conditions have to be observed:

- *Forces and loads considered when evaluating the bearing, should correspond to the real operating conditions.*
- *Proper lubrication should be assured during the entire operative period.*
- *Experience shows that the failure of many bearings does not depend only on fatigue, there are other factors besides this such as: selection of an inadequate bearing type, improper operation or lubrication, outer particles in bearings etc.*

BASIC RATING LIFE

The basic rating life of a single bearing or of a group of identical bearings operating under the same conditions, is the life corresponding to a reliability of 90%. The average life of a group of bearings is higher than the basic rating life. Basic rating life is marked with L_{10} (millions of revolutions) or with L_{10h} (operating hours). L_{10} can be calculate using the equation

$$L_{10} = (C/P)^p$$

where:

- L_{10} is the basic rating life, in millions of revolution;
- C is the basic dynamic load, N;
- P is the equivalent dynamic bearing load, N;
- p is the exponent of the life equation with the following values;
- $P=3$ for ball bearings;
- $P=10/3$ for roller bearings;

Para los rodamientos que operen a velocidad constante, la durabilidad con fatiga nominal, expresada en horas de funcionamiento, podrá calcularse con la presente ecuación:

$$L_{10h} = (1.000.000 / n \cdot 60) \cdot (C / P)^P$$

donde:

n correspondiente a la velocidad rotativa, expresada en rpm.

La tabla 1 expone los valores relativos a la durabilidad con fatiga nominal L_{10} (en millones de giros) en función con la relación C/P. Las tablas 1.1 y 1.2 exponen, respectivamente para los rodamientos de bolas y para los rodamientos de rodillos los valores relativos a la durabilidad con fatiga nominal L_{10h} (en horas de servicio) en función a la relación C/P y a la velocidad. En la determinación de las dimensiones del rodamiento es necesario basar los cálculos sobre durabilidad a la fatiga nominal correspondiente al efectivo empleo. Generalmente esto depende del tipo de máquina, de la durabilidad requerida y de los requisitos inherentes a la seguridad de funcionamiento.

For bearings operating hours, can be calculated using the equation:

$$L_{10h} = (1.000.000 / n \cdot 60) \cdot (C / P)^P$$

where:

n is the rotation speed, expresses in rotations per minutes.

Values of the basic rating life L_{10} (millions of revolutions) as a function of the ratio C/P, can be found in table 2. Values of the basic rating life L_{10h} (operating hours) as a function of the ratio C/P and speed can be found in table 2.2 for ball bearings and 2.3 for roller bearing. To determinate bearing size it is necessary to base the calculations on the rating life corresponding to the purpose of operation. Usually this depends on type of machinery, on the service life and on the requirements regarding operational safety.

1 - Relación de carga C/P para durabilidad L_{10h} millones de giros Load ratio C/P for various lifes values L_{10h} (milions of revolution)

L_{10h}	C/P		L_{10h}	C/P		L_{10h}	C/P	
	Rodamientos de bolas Ball bearings	Rodamientos de rodillos Roller bearings		Rodamientos de bolas Ball bearings	Rodamientos de rodillos Roller bearings		Rodamientos de bolas Ball bearings	Rodamientos de rodillos Roller bearings
0.5	0.793	0.812	220	6.04	5.04	1 800	12.2	9.48
0.75	0.909	0.917	240	6.21	5.18	1 900	12.4	9.63
1	1	1	260	6.38	5.3	2 000	12.6	9.78
1.5	1.14	1.13	280	6.54	5.42	2 200	13	10.1
2	1.26	1.24	300	6.69	5.54	2 400	13.4	10.3
3	1.44	1.39	320	6.84	5.64	2 600	13.8	10.6
4	1.59	1.52	340	6.98	5.75	2 800	14.1	10.8
5	1.71	1.62	360	7.11	5.85	3 000	14.4	11
6	1.82	1.71	380	7.24	5.94	3 200	14.7	11.3
8	2	1.87	400	7.37	6.03	3 400	15	11.5
10	2.15	2	420	7.49	6.12	3 600	15.3	11.7
12	2.29	2.11	440	7.61	6.21	3 800	15.6	11.9
14	2.41	2.21	460	7.72	6.29	4 000	15.9	12
16	2.52	2.3	480	7.83	6.37	4 500	16.5	12.5
18	2.62	2.38	500	7.94	6.45	5 000	17.1	12.9
20	2.71	2.46	550	8.19	6.64	5 500	17.7	13.2
25	2.92	2.63	600	8.43	6.81	6 000	18.2	13.6
30	3.11	2.77	650	8.66	6.98	6 500	18.7	13.9
35	3.27	2.91	700	8.88	7.14	7 000	19.1	14.2
40	3.42	3.02	750	9.09	7.29	7 500	19.6	14.5
45	3.56	3.13	800	9.28	7.43	8 000	20	14.8
50	3.68	3.23	850	9.47	7.56	8 500	20.4	15.1
60	3.91	3.42	900	9.65	7.7	9 000	20.6	15.4
70	4.12	3.58	950	9.83	7.82	9 500	21.2	15.6
80	4.31	3.72	1 000	10	7.94	10 000	21.5	15.8
90	4.48	3.86	1 100	10.3	8.17	12 000	22.9	16.7
100	4.64	3.98	1 200	10.6	8.39	14 000	24.1	17.5
120	4.93	4.2	1 300	10.9	8.59	16 000	25.2	18.2
140	5.19	4.4	1 400	11.2	8.79	18 000	26.2	18.9
160	5.43	4.58	1 500	11.4	8.97	20 000	27.1	19.5
180	5.65	4.75	1 600	11.7	9.15	25 000	29.2	20.9
200	5.85	4.9	1 700	11.9	9.31	30 000	31.1	22

1.1 - Rodamientos de bolas - relación de carga C/P para durabilidad L_{10h} en horas a diversas velocidades (rpm) Ball bearings - load ratio C/P for various rating lifes L_{10h} (operating hours) at various speed n (r/min)

L_{10h}	C/P cuando $n=$		C/P when $n=$					
	50	100	200	300	500	1000	1500	2000
100	0.67	0.84	1.06	1.22	1.44	1.82	2.06	2.29
500	1.14	1.44	1.82	2.08	2.47	3.11	3.56	3.91
1000	1.44	1.82	2.29	2.62	3.11	3.21	4.48	4.93
1250	1.55	1.96	2.47	2.82	3.35	4.22	4.83	5.31
1600	1.69	2.13	2.68	3.07	3.63	4.58	5.24	5.77
2000	1.82	2.29	2.88	3.3	3.91	4.93	5.65	6.21
2500	1.96	2.47	3.11	3.56	4.22	5.31	6.08	6.69
3200	2.13	2.68	3.37	3.86	4.58	5.77	6.6	7.27
4000	2.29	2.88	3.63	4.16	4.93	6.21	7.11	7.83
5000	2.47	3.11	3.91	4.48	5.31	6.69	7.66	8.43
6300	2.66	3.36	4.23	4.84	5.74	7.23	8.28	9.11
8000	2.88	3.63	4.58	5.24	6.21	7.83	8.96	9.86
10000	3.11	3.91	4.93	5.65	6.69	8.43	9.65	10.6
12500	3.35	4.22	5.31	6.08	7.21	9.09	10.4	11.4
16000	3.63	4.58	5.77	4.6	7.83	9.8	11.3	12.4
20000	3.91	4.93	6.21	7.11	8.43	10.6	12.2	13.4
25000	4.22	5.31	6.69	7.66	9.09	11.4	13.1	14.4
32000	4.58	5.77	7.27	8.32	9.86	12.4	14.2	15.7
40000	4.93	6.21	7.83	9.86	10.6	13.4	15.3	16.9
50000	5.31	6.69	8.43	9.65	11.4	14.4	16.5	18.2
63000	5.74	7.23	9.11	10.4	12.4	15.6	17.8	19.6
80000	6.21	7.83	9.88	11.3	13.4	16.9	19.3	21.3
100000	6.69	8.43	10.6	12.2	14.4	18.2	20.8	22.9
200000	8.43	10.6	13.4	15.3	18.2	22.9	26.2	28.8

L_{10h}	C/P cuando $n=$		C/P when $n=$					
	3000	4000	5000	8000	10000	15000	20000	30000
100	2.62	2.88	3.11	3.63	3.91	4.48	4.93	5.65
500	4.48	4.93	5.31	6.21	6.69	7.66	8.43	9.65
1000	5.65	6.21	6.69	7.83	8.43	9.65	10.6	12.2
1250	6.08	6.69	7.21	8.43	9.09	10.4	11.4	13.1
1600	6.6	7.27	7.83	9.16	9.86	11.3	12.4	14.2
2000	7.11	7.83	8.43	9.86	10.6	12.2	13.4	15.3
2500	7.66	8.43	9.09	10.6	11.4	13.1	14.4	16.5
3200	8.32	9.16	9.86	11.5	12.4	14.2	15.7	17.9
4000	8.96	9.86	10.6	12.4	13.4	15.3	16.9	19.3
5000	9.65	10.6	11.4	13.4	14.4	16.5	18.2	20.8
6300	10.4	11.5	12.4	14.5	15.6	17.8	19.6	22.5
8000	11.3	12.4	13.4	15.7	16.9	19.3	21.3	24.3
10000	12.2	13.4	14.4	16.9	18.2	20.8	22.9	26.2
12500	13.1	14.4	15.5	18.2	19.6	22.4	24.7	28.2
16000	14.2	15.7	16.9	19.7	21.3	24.3	26.8	30.7
20000	15.3	16.9	18.2	21.3	22.9	26.2	28.8	33
25000	16.5	18.2	19.6	22.9	24.7	28.2	31.1	35.6
32000	17.9	19.7	21.3	24.9	26.8	30.7	33.7	38.6
40000	19.3	21.3	22.9	26.8	28.8	33	36.3	41.6
50000	20.8	22.9	24.7	28.8	31.1	35.6	39.1	44.8
63000	22.5	24.7	26.6	31.2	33.6	38.4	42.3	48.4
80000	24.3	26.8	28.8	33.7	36.3	41.6	45.8	52.4
100000	26.2	28.8	31.3	36.3	39.1	44.8	49.3	56.5
200000	33	36.3	39.1	45.8	49.3	56.5	62.1	71.1

1.2- Rodamientos de rodillos - relación de carga C/P para durabilidad L_{10h} en horas a diversas velocidades (rpm) Roller bearings - load ratio C/P for various rating lifes L_{10h} (operating hours) at various speed n (r/min)

L_{10h}	C/P cuando $n=$		C/P when $n=$					
	50	100	200	300	500	1000	1500	2000
100	0.7	0.86	1.06	1.19	1.39	1.71	1.93	2.11
500	1.13	1.39	1.71	1.93	2.25	2.77	3.13	3.42
1000	1.39	1.71	2.11	2.38	2.77	3.42	3.86	4.2
1250	1.49	1.83	2.25	2.54	2.97	3.65	4.12	4.5
1600	1.6	1.97	2.43	2.74	3.19	3.93	4.44	4.84
2000	1.71	2.11	2.59	2.93	3.42	4.2	4.75	5.18
2500	1.83	2.25	2.77	3.13	3.65	4.5	5.08	5.54
3200	1.97	2.43	2.99	3.37	3.93	4.84	5.47	5.96
4000	2.11	2.59	3.19	3.61	4.2	5.18	5.85	6.37
5000	2.25	2.77	3.42	3.86	4.5	5.54	6.25	6.81
6300	2.42	2.97	3.66	4.13	4.82	5.93	6.7	7.3
8000	2.59	3.19	3.93	4.44	5.18	6.37	7.2	7.85
10000	2.77	3.42	4.2	4.75	5.54	6.81	7.7	8.39
12500	2.97	3.65	4.5	5.06	5.92	7.29	8.23	8.97
16000	3.19	3.93	4.84	5.47	6.37	7.85	8.86	9.66
20000	3.42	4.2	5.18	5.85	6.81	8.39	9.48	10.3
25000	3.65	4.5	5.54	6.25	7.29	8.97	10.1	11
32000	3.93	4.84	5.96	6.73	7.85	9.66	10.9	11.9
40000	4.2	5.18	6.37	7.2	8.39	10.3	11.7	12.7
50000	4.5	5.54	6.81	7.7	8.97	11	12.5	13.6
63000	4.82	5.93	7.3	8.25	9.61	11.8	13.4	14.6
80000	5.18	6.37	7.85	8.86	10.3	12.7	14.4	15.7
100000	5.54	6.81	8.39	9.48	11	13.6	15.4	16.7
200000	6.81	8.39	10.3	11.7	13.6	16.7	18.9	20.6

L_{10h}	C/P cuando $n=$		C/P when $n=$					
	3000	4000	5000	8000	10000	15000	20000	30000
100	2.38	2.59	2.77	3.19	3.42	3.86	4.2	4.75
500	3.86	4.2	4.5	5.18	5.54	6.25	6.81	7.7
1000	4.75	5.18	5.54	6.37	6.81	7.7	8.39	9.48
1250	5.08	5.54	5.92	6.81	7.29	8.23	8.97	10.1
1600	5.47	5.96	6.37	7.34	7.85	8.86	9.66	10.9
2000	5.85	6.37	6.81	7.85	8.39	9.48	10.3	11.7
2500	6.25	6.81	7.29	8.39	8.97	10.1	11	12.5
3200	6.73	7.34	7.85	9.03	9.66	10.9	11.9	13.4
4000	7.2	7.85	8.39	9.66	10.3	11.7	12.7	14.4
5000	7.7	8.39	8.97	10.3	11	12.5	13.5	15.4
6300	8.25	8.99	9.61	11.1	11.8	13.4	14.6	16.5
8000	8.86	9.66	10.3	11.9	12.7	14.4	15.7	17.7
10000	9.48	10.3	11	12.7	13.6	15.4	16.7	18.9
12500	10.1	11	11.8	13.6	14.5	16.4	17.9	20.2
16000	10.9	11.9	12.7	14.6	15.7	17.7	19.3	21.8
20000	11.7	12.7	13.6	15.7	16.7	18.9	20.6	23.3
25000	12.5	13.6	14.5	16.7	17.9	20.2	22	24.9
32000	13.4	14.6	15.7	18	19.3	21.8	23.7	26.8
40000	14.4	15.7	16.7	19.3	20.6	23.3	25.4	28.7
50000	15.4	16.7	17.9	20.6	22	24.9	27.1	30.6
63000	16.5	17.9	19.2	22.1	23.6	26.7	29.1	32.8
80000	17.7	19.3	20.6	23.7	25.4	28.7	31.2	35.3
100000	18.9	20.6	22	25.4	27.1	30.6	33.4	37.7
200000	23.3	25.4	27.1	31.2	33.4	37.7	41.1	46.4

LÍMITE DE VELOCIDAD

El límite de velocidad se puede definir como la velocidad de rotación más elevada que un rodamiento puede alcanzar en función de su empleo, sin comprometer sus prestaciones ni su durabilidad. El límite de velocidad de los rodamientos depende de varios factores como por ejemplo: tipo de rodamiento, magnitud de la carga, clase de tolerancia, configuración de la jaula, juego de trabajo, lubricante, condiciones de lubricación y de refrigeración, etc. En caso de lubricación con aceite, el límite de velocidad podrá ser determinado en modo aproximado, para los rodamientos radiales, en función del diámetro medio del rodamiento y para los rodamientos axiales, en función del diámetro y la carga de montaje del rodamiento. En las tablas de los datos característicos se suministran los límites de velocidad referidos tanto a la lubricación con aceite como también a aquella con grasa. Cuando no se conozcan muy bien las condiciones operativas de los rodamientos y la calidad del lubricante, se aconseja que la velocidad efectiva no supere el 75% de los valores de velocidad suministrados en el presente catálogo. En caso de cargas de gran magnitud, de durabilidad nominal inferior a las 75000 horas de servicio y de rodamientos con diámetro medio superior a 100 mm, los valores de velocidad suministrados por el catálogo deberán ser multiplicados por el factor f . En caso carga combinada, los valores de velocidad suministrados en el catálogo se deberán multiplicar por el factor f_1 .

CASOS ESPECIALES. BAJAS VELOCIDADES

A velocidades significativamente reducidas no se podrá formar la película de lubricante elastodinámico entre las superficies a contacto del cuerpo envolvente y el aro de rodadura. En este caso se deberán emplear lubricantes con determinados aditivos.

CONDICIONES ESTACIONARIAS

Si se presentan condiciones estacionarias prolongadas los rodamientos tenderán a vibrar, los micro-movimientos que se dan en las superficies de contacto entre el elemento envolvente y la pista de deslizamiento podrían dañar estas últimas, con un consecuente aumento de nivel de las vibraciones y disminución de la durabilidad. Resulta además preferible la lubricación con aceite respecto a la grasa.

TOLERANCIAS DE LOS RODAMIENTOS

Las tolerancias de los rodamientos han sido normalizadas a nivel nacional e internacional de conformidad con las normas ISO. Los rodamientos se fabrican en general con clase de tolerancias P0. Bajo demanda, pueden además ser fabricados en clases de tolerancia P6, P5, P4 y P2. Estos últimos rodamientos se emplean para aplicaciones especiales, como guía de alta precisión de árboles o altísimas velocidades de rodamiento. Se suministran tablas para las tolerancias relativas a:

- dimensiones de los rodamientos;
- racores, perfiles de montaje.

SPEED LIMIT

The speed limit can be defined as the maximum rotation speed reached by a bearing, without compromising its performances. The speed limit depends on different factors, such as: type of bearing, magnitude of load, tolerance class, cage design, operational clearance, lubricant, lubrication and cooling conditions, and so on. In case of oil lubrication, the bearing speed limit can be approximately determined for radial bearings, as a function of the mean bearing diameter; concerning thrust bearings, instead, speed limit is determined as a function of the dimension and weight of the bearing's outting. In bearing tables, the value of speed limit are given for both grease and oil lubrication. In the case of insufficient informations about quality of lubrication and operating conditions, the effective speed is recommended not to exceed the 75% of the speed indicated in this catalogue. In the case of heavy loads, when the rating life is shorter than 75000 operating hours and bearing mean diameter is larger than 1000 mm, speed limits indicated in this catalogue, have to be multiplied by factor "f". If the load is combined, the speed from this catalogue have to be multiplied by factor "f1".

SPECIAL CASE. LOW SPEEDS

At very low speeds it is impossible the formation of an elastohydrodynamic lubricant film between the rolling elements and raceway. Lubricants with special additives should be used in such cases.

STATIONARY CONDITIONS

If in long term stationary conditions, bearings start vibrating, the micromovement at the rolling elements and at the raceway contacts produces damages on the contact surfaces. In this way vibration level is increased and the life is shorter. Oil lubrication is preferable to grease lubrication.

BEARINGS TOLERANCES

In accordance with ISO rules bearing tolerances have been nationally and internationally standardized. Bearings are usually manufactured to the tolerance class P0. Under request they can be supplied with P6, P5, P4 and P2 tolerance classes. These latter bearings are used for special applications, such as very high speeds or very accurate shaft guidance. The value of the limit for these tolerance classes are given for:

- dimensions of bearings;
- mounting chamfer.

SÍMBOLOS

d	Diámetro nominal del orificio
d_{mp}	Diámetro medio del orificio
V_{dp}	Variación del diámetro del orificio
V_{dmp}	Variación del diámetro medio del orificio
Δd_{mp}	Diferencia del diámetro del orificio respecto al valor nominal ($\Delta d_{mp} = d_{mp} - d$)
D	Diámetro nominal externo
D_{mp}	Diámetro externo medio
V_{Dp}	Variación del diámetro externo
V_{Dmp}	Variación del diámetro externo medio
ΔD_{mp}	Diferencia del diámetro externo medio respecto al valor nominal ($\Delta D_{mp} = D_{mp} - D$)
K_{ia}	Concentricidad de rotación del aro interior en el rodamiento completo
K_{ea}	Concentricidad de rotación del aro exterior en el rodamiento completo
B	Medida nominal de la altura del aro interior
C	Medida nominal de la altura del aro exterior
B_s	Medida individual de la altura del aro interior
C_s	Medida individual de la altura del aro exterior
ΔB_s	Diferencia de una única medida de la altura del aro interior ($\Delta B_s = B_s - B$)
ΔC_s	Diferencia de una única medida de la altura del aro exterior ($\Delta C_s = C_s - C$)
S_d	Defecto de cuadratura de las caras respecto al orificio del aro interior
S_D	Variación de la inclinación cilíndrica exterior respecto a la superficie lateral del aro exterior
S_{ia}	Planeidad de rotación de la superficie lateral del aro interior respecto al camino de rodadura en el rodamiento rígido completo
S_{ea}	Planeidad de rotación de la superficie lateral del aro exterior respecto al camino de rodadura en el rodamiento rígido completo
T	Medida nominal del ancho del rodamiento
T_s	Ancho total de un rodamiento de rodillos cónicos
T_{1s}	Ancho total del rodamiento de rodillos cónicos, con el cono montado en una copa muestra
T_{2s}	Ancho total del rodamiento de rodillos cónicos, con la copa montada en un cono muestra
ΔT_s	Diferencia de la medida individual del ancho del rodamiento de rodillos cónicos respecto al valor nominal ($\Delta T_s = T_s - T$)
ΔT_{1s}	Diferencia de la medida individual del ancho del rodamiento de rodillos cónicos respecto al valor nominal ($\Delta T_{1s} = T_{1s} - T$)
ΔT_{2s}	Diferencia de la medida individual del ancho del rodamiento de rodillos cónicos respecto al valor nominal ($\Delta T_{2s} = T_{2s} - T$)

SYMBOLS

d	Nominal bore diameter
d_{mp}	mean bore diameter
V_{dp}	Bore diameter variation
V_{dmp}	Mean bore diameter variation
Δd_{mp}	Deviation of bore diameter from nominal value ($\Delta d_{mp} = d_{mp} - d$)
D	Nominal outer diameter
D_{mp}	Mean outer diameter
V_{Dp}	Outer diameter variation
V_{Dmp}	Mean outer diameter variation
ΔD_{mp}	Deviation of the mean outer diameter from nominal value ($\Delta D_{mp} = D_{mp} - D$)
K_{ia}	Concentricity radial run out of assembled bearing inner ring
K_{ea}	Concentricity radial run out of assembled bearing outer ring
B	Nominal height of the inner ring
C	Nominal height of the outer ring
B_s	Single height of the inner ring
C_s	Single height of the outer ring
ΔB_s	Inner ring single height deviation as regards to nominal dimension ($\Delta B_s = B_s - B$)
ΔC_s	Outer ring single height deviation as regards to nominal dimension ($\Delta C_s = C_s - C$)
S_d	Side face run out with reference to bore of the inner ring
S_D	Variation in inclination of outside cylindrical surface to outer ring side face
S_{ia}	Revolution flatness of inner ring side surface, as regards to the raceway of complete bearing
S_{ea}	Revolution flatness of outer ring side surface, as regards to the raceway of complete bearing
T	Nominal width of bearing
T_s	Total width of tapered roller bearing
T_{1s}	Total width of tapered roller bearing, with the cone assembled on a sample torque
T_{2s}	Total width of tapered roller bearing, with the torque assembled on a sample cone
ΔT_s	Deviation of single measurement concerning the width of tapered roller bearing, from nominal value ($\Delta T_s = T_s - T$)
ΔT_{1s}	Deviation of single measurement concerning the width of tapered roller bearing, from nominal value ($\Delta T_{1s} = T_{1s} - T$)
ΔT_{2s}	Deviation of single measurement concerning the width of tapered roller bearing, from nominal value ($\Delta T_{2s} = T_{2s} - T$)

Tolerancias para rodamientos radiales de la clase de precisión normal (excluidos los rodamientos de rodillos cónicos)
Tolerances for radial bearings normal precision (tapered roller bearings excluded)

Anillo interno - Inner ring
 $\mu\text{m} : 0.001 \text{ mm}$

d		Δd_{mp}		V_{dp}			V_{dmp}	ΔB_s		V_{Bs}	K_{ia}
		Serie diametral - Diameters series									
más de - over	hasta - up to	máx	mín	8,9 max	0,1 max	2,3,4 max	máx	máx	mín	máx	máx
mm	mm	μm	μm	μm	μm	μm	μm	μm	μm	μm	μm
2,5	10	0	-8	10	8	6	6	0	-120	15	10
10	18	0	-8	10	8	6	6	0	-120	20	10
18	30	0	-10	13	10	8	8	0	-120	20	13
30	50	0	-12	15	12	9	9	0	-120	20	15
50	80	0	-15	19	19	11	11	0	-150	25	20
80	120	0	-20	25	25	15	15	0	-200	25	25
120	180	0	-25	31	31	19	19	0	-250	30	30
180	250	0	-30	38	38	23	23	0	-300	30	40
250	315	0	-35	44	44	26	26	0	-350	35	50
315	400	0	-40	50	50	30	30	0	-400	40	60
400	500	0	-45	56	56	34	34	0	-450	50	65
500	630	0	-50	63	63	38	38	0	-500	60	70
630	800	0	-75	-	-	-	-	0	-750	70	80
800	1000	0	-100	-	-	-	-	0	-1000	80	90
1000	1250	0	-125	-	-	-	-	0	-1250	100	100
1250	1600	0	-160	-	-	-	-	0	-1600	120	120
1600	2000	0	-200	-	-	-	-	0	-2000	140	140

Anillo externo - Outer ring

D		ΔD_{mp}		V_{Dp}			*Rodamientos con blindajes estancos Sealed bearings	V_{Dmp}	K_{ea}		
		Serie diametrales - Diameters series									
más de - over	hasta - up to	máx	mín	8,9 max	0,1 max	2,3,4 max	max	max	max		
mm	mm	μm	μm	μm	μm	μm	μm	μm	μm		
6	18	0	-8	10	8	6	10	6	15		
18	30	0	-9	12	9	7	12	7	15		
30	50	0	-11	14	11	8	16	8	20		
50	80	0	-13	16	13	10	20	10	25		
80	120	0	-15	19	19	11	26	11	35		
120	150	0	-18	23	23	14	30	14	40		
150	180	0	-25	31	31	19	38	19	45		
180	250	0	-30	38	38	23	-	23	50		
250	315	0	-35	44	44	26	-	26	60		
315	400	0	-40	50	50	30	-	30	70		
400	500	0	-45	56	56	34	-	34	80		
500	630	0	-50	63	63	38	-	38	100		
630	800	0	-75	94	94	55	-	55	120		
800	1000	0	-100	125	125	75	-	75	140		
1000	1250	0	-125	-	-	-	-	-	160		
1250	1600	0	-160	-	-	-	-	-	190		
1600	2000	0	-200	-	-	-	-	-	220		
2000	2500	0	-250	-	-	-	-	-	250		

* Aplicable solo a los rodamientos de la serie diametrales 2, 3, 4.

* Applicable only to bearings 2, 3, 4 diameter series

Tolerancias para rodamientos de rodillos cónicos de la clase de precisión normal
Tolerances for tapered roller bearings normal precision

Anillo interno y ancho del rodamiento - Inner ring and bearing width μm : 0.001 mm

d		Δd_{mp}		V_{dp}	V_{dmp}	$\Delta B_s - \Delta C_s$		K_{ia}	ΔT_s		ΔT_{1s}		ΔT_{2s}	
más de - over	hasta - up to	máx	mín	máx	máx	máx	mín	máx	máx	mín	máx	mín	máx	máx
mm	mm	μm	μm	μm	μm	μm	μm	μm	μm	μm	μm	μm	μm	μm
10	18	0	-12	12	9	0	-120	15	200	0	100	0	100	0
18	30	0	-12	12	9	0	-120	18	200	0	100	0	100	0
30	50	0	-12	12	9	0	-120	20	200	0	100	0	100	0
50	80	0	-15	15	11	0	-150	25	200	0	100	0	100	0
80	120	0	-20	20	15	0	-200	30	200	-200	100	-100	100	-100
120	180	0	-25	25	19	0	-250	35	350	-250	150	-150	200	-100
180	250	0	-30	30	23	0	-300	50	350	-250	150	-150	200	-100
250	315	0	-35	35	26	0	-350	60	350	-250	150	-150	200	-100
315	400	0	-40	40	30	0	-400	70	400	-400	200	-200	200	-200
400	500	0	-45	45	34	0	-450	70	400	-400	-	-	-	-
500	630	0	-50	50	38	0	-500	85	500	-500	-	-	-	-
630	800	0	-75	75	56	0	-750	100	600	-600	-	-	-	-
800	1000	0	-100	100	75	0	-1000	120	750	-750	-	-	-	-
1000	1250	0	-125	-	-	0	-1250	120	1000	-1000	-	-	-	-

Anillo externo - Outer ring

D		ΔD_{mp}		V_{Dp}	V_{Dmp}	K_{ea}
más de - over	hasta - up to	máx	mín	máx	máx	máx
mm	mm	μm	μm	μm	μm	μm
18	30	0	-12	12	9	18
30	50	0	-14	14	11	20
50	80	0	-16	16	12	25
80	120	0	-18	18	14	35
120	150	0	-20	20	15	40
150	180	0	-25	25	19	45
180	250	0	-30	30	23	50
250	315	0	-35	35	26	60
315	400	0	-40	40	30	70
400	500	0	-45	45	34	80
500	630	0	-50	50	38	100
630	800	0	-75	75	55	120
800	1000	0	-100	100	75	120
1000	1250	0	-125	125	94	120
1250	1600	0	-160	160	120	120

Orificios cónicos
Conical bore

 Semiángulo del cono α :
 Half angle of cone α :

 $\alpha = 2^\circ 23' 9,4''$ (conicidad 1:12)
 (taper-ratio 1:12)

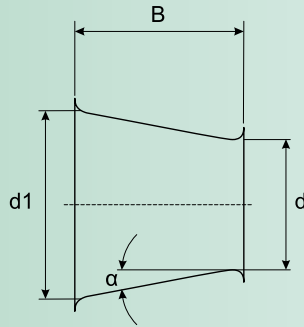
 $\alpha = 0^\circ 57' 17,4''$ (conicidad 1:30)
 (taper-ratio 1:30)

 Diámetro mayor teórico d_1 :
 Theoretical bigger diameter d_1 :

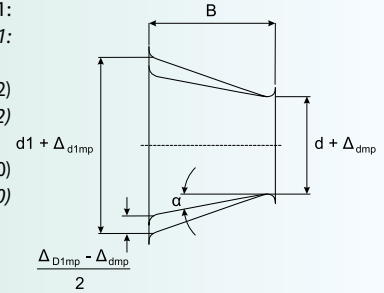
 $d_1 = d + (1/12) \cdot B$ (conicidad 1:12)
 (taper-ratio 1:12)

 $d_1 = d + (1/30) \cdot B$ (conicidad 01:30)
 (taper-ratio 1:30)

Tolerancias para orificios cónicos
Tolerances for conical bore
Conicidad 1 : 12 - Taper-ratio 1 : 12
 $\mu\text{m} : 0.001 \text{ mm}$

d		Clase de tolerancia normal, P6 Normal class of tolerance, P6					Clase de tolerancia normal, P5 Normal class of tolerance, P5				
		Δd_{mp}	$V_{dp}^{1)}$	Δd_{1mp}	$-\Delta d_{mp}$	Δd_{mp}	$V_{dp}^{1)}$	Δd_{1mp}	$-\Delta d_{mp}$		
más de - over	hasta - up to	máx	mín	máx	0,1 max	2,3,4 max	máx	mín	mín	máx	máx
mm	mm	μm	μm	μm	μm	μm	μm	μm	μm	μm	μm
18	30	21	0	13	21	0	13	0	13	13	0
30	50	25	0	15	25	0	16	0	15	16	0
50	80	30	0	19	30	0	19	0	19	19	0
80	120	35	0	25	35	0	22	0	22	22	0
120	180	40	0	31	40	0	25	0	25	25	0
180	250	46	0	38	46	0	29	0	29	29	0
250	315	52	0	44	52	0	32	0	32	32	0
315	400	57	0	50	57	0	36	0	36	36	0
400	500	63	0	56	63	0	40	0	-	40	0
500	630	70	0	-	70	0	44	0	-	44	0
630	800	80	0	-	80	0	50	0	-	50	0
800	1000	90	0	-	90	0	56	0	-	56	0

Conicidad 1 : 30 - Taper-ratio 1 : 30
 $\mu\text{m} : 0.001 \text{ mm}$

d		Clase de tolerancia normal Normal class of tolerance				
		Δd_{mp}	$V_{dp}^{1)}$	Δd_{1mp}	$-\Delta d_{mp}$	
más de - over	hasta - up to	máx	mín	máx	0,1 max	2,3,4 max
mm	mm	μm	μm	μm	μm	μm
80	120	20	0	25	40	0
120	180	25	0	31	50	0
180	250	30	0	38	55	0
250	315	35	0	44	60	0
315	400	40	0	50	65	0
400	500	45	0	56	75	0
500	630	50	0	63	85	0
630	800	75	0	-	100	0
800	1000	100	0	-	100	0

1) Valido en cada uno de los planos del orificio.

1) Valid for every radial flat of bore.

Tolerancia para rodamientos axiales
Tolerances for axial bearings

Anillo para eje - Shaft locating washer

Clase de tolerancia normal, P6, P5
Normal class of tolerance, P6, P5

d		Δd_{mp}		V_{dp}	$S_i^{(1)}$		
más de - over	hasta - up to	máx	mín	máx	máx	máx	máx
mm	mm	μm	μm	μm	μm	μm	μm
-	18	0	-8	6	10	5	3
18	30	0	-10	8	10	5	3
30	50	0	-12	9	10	6	3
50	80	0	-15	11	10	7	4
80	120	0	-20	15	15	8	4
120	180	0	-25	19	15	9	5
180	250	0	-30	23	20	10	5
250	315	0	-35	26	25	13	7
315	400	0	-40	30	30	15	7
400	500	0	-45	34	30	18	9
500	630	0	-50	38	35	21	11
630	800	0	-75	-	40	25	13
800	1000	0	-100	-	45	30	15
1000	1250	0	-125	-	50	35	18

Anillo para alojamiento - Housing locating washer

Clase de tolerancia normal, P6, P5
Normal class of tolerance, P6, P5

D		ΔD_{mp}		V_{Dp}	$S_i^{(1)}$		
más de - over	hasta - up to	máx	mín	máx	máx	máx	máx
mm	mm	μm	μm	μm	μm	μm	μm
18	30	0	-13	10	10	5	3
30	50	0	-16	12	10	6	3
50	80	0	-19	14	10	7	4
80	120	0	-22	17	15	8	4
120	180	0	-25	19	15	9	5
180	250	0	-30	23	20	10	5
250	315	0	-35	26	25	13	7
315	400	0	-40	30	30	15	7
400	500	0	-45	34	30	18	9
500	630	0	-50	38	35	21	11
630	800	0	-75	55	40	25	13
800	1000	0	-100	75	45	30	15
1000	1250	0	-125	-	50	35	18

1) Valores excluidos para los rodamientos axiales orientables de rodillos. Para rodamientos con el mismo \varnothing externo los valores son los mismos tanto para rodamientos de doble efecto como también de simple efecto.
1) These value are not valid for axial roller bearings for bearings having the same outer diameter. Value are the same for both double acting and single acting bearings.

Altura del rodamiento - Bearing width

d		ΔT_s		ΔT_{1s}		ΔT_{2s}		ΔT_{3s}		ΔT_{4s}	
más de - over	hasta - up to	máx	mín	máx	mín	máx	mín	máx	mín	máx	mín
mm	mm	μm	μm	μm	μm	μm	μm	μm	μm	μm	μm
-	30	20	-250	100	-250	150	-400	300	-400	20	-300
30	50	20	-250	100	-250	150	-400	300	-400	20	-300
50	80	20	-300	100	-300	150	-500	300	-500	20	-400
80	120	25	-300	150	-300	200	-500	400	-500	25	-400
120	180	25	-400	150	-400	200	-600	400	-600	25	-500
180	250	30	-400	150	-400	250	-600	500	-600	30	-500
250	315	40	-400	200	-400	350	-700	600	-700	40	-700
315	400	40	-500	200	-500	350	-700	600	-700	40	-700
400	500	50	-500	300	-500	400	-900	750	-900	50	-900
500	630	60	-600	350	600	500	-1100	900	-1100	60	-1200
630	800	70	-750	400	-750	600	-1300	1100	-1300	70	-1400
800	1000	80	-1000	450	-1000	700	-1500	1300	-1500	80	-1800
1000	1250	100	-1400	500	-1400	900	-1800	1600	-1800	100	-2400

JUEGO RADIAL DE LOS RODAMIENTOS DE BOLAS Y DE RODILLOS

Uno de los principales factores que influyen en la durabilidad de los rodamientos de bolas y de rodillos es el juego radial, determinado como el valor medio de varias medidas del desplazamiento total sobre el plano perpendicular al eje del rodamiento. Dicho desplazamiento es típico de uno de los anillos del rodamiento (el otro es estacionario) durante la rotación en varias direcciones angulares, tanto respecto al anillo rotativo como también respecto al estacionario, ya en diversas posiciones angulares de la serie de bolas o rodillos respecto a los anillos mismos.

Considerados los diversos coeficientes de juego requeridos en la entrega, los rodamientos radiales se realizan según varios grupos de juego inicial. En general, los rodamientos radiales de bolas y de rodillos se realizan según el grupo de juego radial normal, que, en empleos comunes a la mayor parte de los casos, suministran parámetros satisfactorios de funcionamiento. El juego radial se evidencia con el agregado a la sigla del rodamiento de la designación de la clase de precisión (C2, C3, C4, C5). A los rodamientos fabricados con juego radial correspondiente al grupo normal no se asignan ulteriores designaciones convencionales. Las siguientes tablas recogen los valores de juego radial.

RADIAL CLEARANCE OF BALL AND ROLLER BEARINGS

One of the most important factors influencing the life of a roller or ball bearing, is the radial clearance. The latter is determined by a mean of several measurements of total displacement in the plane perpendicular to the bearing axle. This displacement is typical for one of the bearing ring (the other is stationary) during its rotation in different angular directions, both with respect to the rotatable ring and the stationary one, and at different angular positions of the set of balls or rollers with respect to the bearing races.

Because of the different requirements concerning the radial clearance, bearings are manufactured with several initial clearance groups, such as additional groups. Radial bearings are usually manufactured in accordance with the normal clearance group: this enables a satisfactory functioning of the bearing, in the majority of cases. Radial clearance is pointed out by adding the precision class (C2, C3, C4, C5) to bearing group. No further conventional designations are assigned to normal clearance bearings. Values of radial clearances are given below, see tables.

Tabla juego radial de los rodamientos de bolas
Tables of radial clearance for ball bearings

Rodamientos de bolas - Ball bearings												
Diámetro del orificio Bore diameter		C2		Normal Normal		C3		C4		C5		
más de - over	hasta - up to	máx	mín	máx	mín	máx	mín	máx	mín	máx	mín	
mm	mm	µm	µm	µm	µm	µm	µm	µm	µm	µm	µm	
2.5	10	0	7	2	13	8	23	14	29	20	37	
10	18	0	9	3	18	11	25	18	33	25	45	
18	24	0	10	5	20	13	28	20	36	28	48	
24	30	1	11	5	20	13	28	23	41	30	53	
30	40	1	11	6	20	15	33	28	46	40	64	
40	50	1	11	6	23	18	36	30	51	45	73	
50	65	1	15	8	28	23	43	38	61	55	90	
65	80	1	15	10	30	25	51	46	71	65	105	
80	100	1	18	12	36	30	58	53	84	75	120	
100	120	2	20	15	41	36	66	61	97	90	140	
120	140	2	23	18	48	41	81	71	114	105	160	
140	160	2	23	18	53	46	91	81	130	120	180	
160	180	2	25	20	61	53	102	91	147	135	200	
180	200	2	30	25	71	63	117	107	163	150	230	
200	225	2	35	30	85	77	137	127	195	180	270	
225	250	2	40	33	95	87	157	147	225	210	300	
250	280	2	45	35	100	90	170	157	245	230	340	
280	315	3	55	45	115	105	190	175	270	250	370	
315	355	3	55	45	125	115	210	195	300	280	400	
355	400	3	65	55	145	135	240	225	340	320	460	
400	450	5	80	65	170	150	270	250	380	360	510	
450	500	5	90	75	190	170	300	280	420	400	570	
500	560	10	100	80	210	190	335	310	475	450	640	
560	630	10	110	90	230	210	365	340	525	500	700	
630	710	10	120	90	250	220	390	360	570	540	760	
710	800	10	130	100	270	240	420	390	620	590	840	
800	900	20	150	110	300	260	460	420	680	640	920	

Tabla juego radial

Tables of radial clearance

Rodamientos radiales de rodillos cilíndricos - *Cylindrical roller bearings*

Diámetro del orificio Bore diameter		C2		Normal Normal		C3		C4		C5	
más de - over	hasta - up to	máx	mín	máx	mín	máx	mín	máx	mín	máx	mín
mm	mm	µm	µm	µm	µm	µm	µm	µm	µm	µm	µm
-	10	0	30	10	40	25	55	35	65	-	-
10	18	0	30	10	40	25	55	35	65	55	85
18	24	0	30	10	40	25	55	35	65	55	85
24	30	0	30	10	45	30	65	40	70	60	90
30	40	0	35	15	50	35	70	45	80	70	105
40	50	5	40	20	55	40	75	55	90	85	120
50	65	5	45	20	65	45	90	65	105	100	140
65	80	5	55	25	75	55	105	75	125	115	165
80	100	10	60	30	80	65	115	90	140	145	195
100	120	10	65	35	90	80	135	105	160	165	220
120	140	10	75	40	105	90	155	115	180	185	250
140	160	15	80	50	115	100	165	130	195	210	275
160	180	20	85	60	125	110	175	150	215	235	300
180	200	25	95	65	135	125	195	165	235	260	330
200	225	30	105	75	150	140	215	180	255	290	365
225	250	40	115	90	165	155	230	205	280	320	395
250	280	45	125	100	180	175	255	230	310	355	435
280	315	50	135	110	195	195	280	255	340	400	485
315	355	55	145	125	215	215	305	280	370	440	530
355	400	65	160	140	235	245	340	320	415	500	595
400	450	70	190	155	275	270	390	355	465	555	675
450	500	85	205	180	300	300	420	395	515	620	740

Rodamientos orientables de rodillos con orificio cilíndrico - *Spherical roller bearings with cylindrical bore*

Diámetro del orificio Bore diameter		C2		Normal Normal		C3		C4		C5	
más de - over	hasta - up to	máx	mín	máx	mín	máx	mín	máx	mín	máx	mín
mm	mm	µm	µm	µm	µm	µm	µm	µm	µm	µm	µm
18	24	10	20	20	35	35	45	45	60	60	75
24	30	15	25	25	40	40	55	55	75	75	95
30	40	15	30	30	45	45	60	60	80	80	100
40	50	20	35	35	55	55	75	75	100	100	125
50	65	20	40	40	65	65	90	90	120	120	150
65	80	30	50	50	80	80	110	110	145	145	180
80	100	35	60	60	100	100	135	135	180	180	225
100	120	40	75	75	120	120	160	160	210	210	260
120	140	50	95	95	145	145	190	190	240	240	300
140	160	60	110	110	170	170	220	220	280	280	350
160	180	65	120	120	180	180	240	240	310	310	390
180	200	70	130	130	200	200	260	260	340	340	430
200	225	80	140	140	220	220	290	290	380	380	470
225	250	90	150	150	240	240	320	320	420	420	520
250	280	100	170	170	260	260	350	350	460	460	570
280	315	110	190	190	280	280	370	370	500	500	630
315	355	120	200	200	310	310	410	410	550	550	690
355	400	130	220	220	340	340	450	450	600	600	750
400	450	140	240	240	370	370	500	500	660	660	820
450	500	140	260	260	410	410	550	550	720	720	900
500	560	150	280	280	440	440	600	600	780	780	1000
560	630	170	310	310	480	480	650	650	850	850	1100
630	710	190	350	350	530	530	700	700	920	920	1190
710	800	210	390	390	580	580	770	770	1010	1010	1300

Tabla juego radial
Tables of radial clearance
Rodamientos orientables de rodillos con orificio cónico - Spherical roller bearings with conical bore

Diámetro del orificio Bore diameter		C2		Normal Normal		C3		C4		C5	
más de - over	hasta - up to	máx	mín	máx	mín	máx	mín	máx	mín	máx	mín
mm	mm	µm	µm	µm	µm	µm	µm	µm	µm	µm	µm
24	30	20	30	30	40	40	55	55	75	-	-
30	40	25	35	35	50	50	65	65	85	85	105
40	50	30	45	45	60	60	80	80	100	100	130
50	65	40	55	55	75	75	95	95	120	120	160
65	80	50	70	70	95	95	120	120	150	150	200
80	100	55	80	80	110	110	140	140	180	180	230
100	120	65	100	100	135	135	170	170	220	220	280
120	140	80	120	120	160	160	200	200	260	260	330
140	160	90	130	130	180	180	230	230	300	300	380
160	180	100	140	140	200	200	260	260	340	340	430
180	200	110	160	160	220	220	290	290	370	370	470
200	225	120	180	180	250	250	320	320	410	410	520
225	250	140	200	200	270	270	350	350	450	450	570
250	280	150	220	220	300	300	390	390	490	490	620
280	315	170	240	240	330	330	430	430	540	540	680
315	355	190	270	270	360	360	470	470	590	590	740
355	400	210	300	300	400	400	520	520	650	650	820
400	450	230	330	330	440	440	570	570	720	720	910
450	500	260	370	370	490	490	630	630	790	790	1000
500	560	290	410	410	540	540	680	680	870	870	1100
560	630	320	460	460	600	600	760	760	980	980	1230
630	710	350	510	510	670	670	850	850	1090	1090	1360
710	800	390	570	570	750	750	960	960	1220	1220	1500
800	900	440	640	640	840	840	1070	1070	1370	1370	1690

TABLAS DIMENSIÓN DE LOS RACORES (BISEL)

- r1, r3** Biseles en dirección central
- r2, r4** Biseles en dirección axial
- r5 min** Símbolo límite máximo biseles r1, r2, r3, r4
- r1s max, r3s max** Dimensión máxima en dirección radial
- r2s max, r4s max** Dimensión máxima en dirección axial

MOUNTING CHAMFER DIMENSION TOLERANCES

- r1, r3** Chamfer dimension in radial direction
- r2, r4** Chamfer dimension in axial direction
- r5 min** General symbol for minimum limit r1, r2, r3, r4
- r1s max, r3s max** Maximum dimension in radial direction
- r2s max, r4s max** Maximum dimension in axial direction

Dimensiones límite racores para rodamientos radiales y axiales Mounting chamfer dimension limits for radial and thrust bearings

rs min	d		Rodamientos rígidos Radial bearings		Rodamientos de empuje Thrust bearings
	más de - over	hasta - up to	r1s, r3s máx	r2s, r4s máx	r1s, r2s máx
0.1	-	-	0.2	0.4	0.2
0.15	-	-	0.3	0.6	0.3
0.2	-	-	0.5	0.8	0.5
0.3	-	40	0.6	1	0.8
0.6	40	-	0.8	1	0.8
1	-	40	1	2	1.5
1.1	40	-	1.3	2	1.5
1	-	50	1.5	3	2.2
1.1	50	-	1.9	3	2.2
1.1	-	120	2	3.5	2.7
1.1	120	-	2.5	4	2.7
1.5	-	120	2.3	4	3.5
1.5	120	-	3	5	3.5
2	-	80	3	4.5	4
2	22	-	3.8	6	4
2	80	220	3.5	5	4
2.1	-	100	3.8	6	4.5
2.1	-	280	4	6.5	4.5
2.1	280	-	4.5	7	4.5
2.5	100	280	4.5	6	-
2.5	280	-	5	7	-
3	-	-	5	8	5.5
3	280	-	5.5	8	5.5
4	-	-	6.5	9	6.5
5	-	-	8	10	8
6	-	-	10	13	10
7.5	-	-	12.5	17	12.5
9.5	-	-	15	19	15
12	-	-	18	24	18
15	-	-	21	30	21
19	-	-	25	38	25

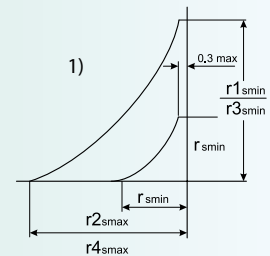
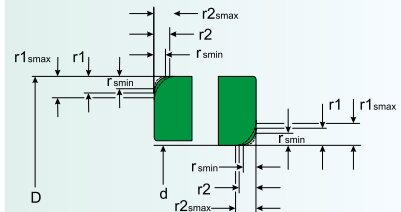
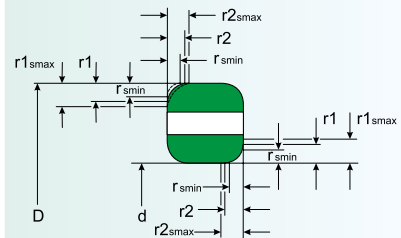

1) Solo para d < 30 mm
1) Only for d < 30 mm

TABLAS DIMENSIÓN DE LOS RACORES (BISEL)
r1, r3 Biseles en dirección central

r2, r4 Biseles en dirección axial

r5 min Símbolo límite máximo biseles r1, r2, r3, r4

r1s max, r3s max Dimensión máxima en dirección radial

r2s max, r4s max Dimensión máxima en dirección axial

MOUNTING CHAMFER DIMENSIONS TOLERANCES
r1, r3 Chamfer dimension in radial direction

r2, r4 Chamfer dimension in axial direction

r5 min General symbol for minimum limit r1, r2, r3, r4

r1s max, r3s max Maximum dimension in radial direction

r2s max, r4s max Maximum dimension in axial direction

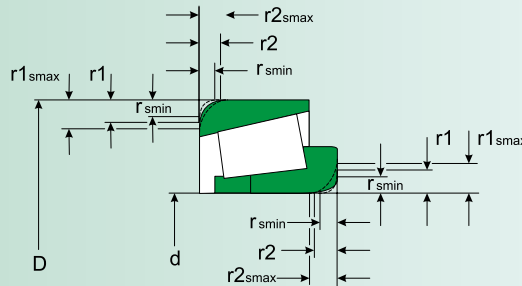
Dimensiones límite racores para rodamientos cónicos de rodillos
Mounting chamfer dimension limits for tapered roller bearings

rs min	d		Rodamientos rígidos Radial bearings	
	más de - over	hasta - up to	r1s, r3s máx	r2s, r4s máx
0.3	-	40	0.7	1.4
	40	-	0.9	1.6
0.6	-	40	1.1	1.7
	40	-	1.3	2
1	-	50	1.6	2.5
	50	-	1.9	3
1.5	-	120	2.3	3
	120	250	2.8	3.5
	250	-	3.5	4
2	-	120	2.8	4
	120	250	3.5	4.5
	250	-	4	5
	250	-	4.5	6
2.5	-	120	3.5	5
	120	250	4	5.5
3	-	120	4	5.5
	120	250	4.5	6.5
	250	400	5	7
4	400	-	5.5	7.5
	-	120	5	7
	120	250	5.5	7.5
5	250	400	6	8
	400	-	6.5	8.5
	-	180	6.5	8
6	180	-	7.5	9
	-	180	7.5	10
	180	-	9	11

MATERIALES UTILIZADOS PARA LA FABRICACIÓN DE LOS RODAMIENTOS

Tanto los anillos como los elementos rotativos de los rodamientos, están sujetos a un elevado nivel de estrés sobre una superficie de contacto muy restringida; por dicho motivo, deben contar con una alta resistencia al desgaste y a la fatiga.

Están por lo tanto principalmente contruidos con acero cromo de elevada calidad, de acuerdo con las normas SAE 52100-CR6 que exponemos en la siguiente tabla que indica la composición química. Bajo demanda pueden ser fabricados también de **acero INOX**.

MATERIAL USADO PARA LA JAULA

Los tipos de jaulas varían según las condiciones de utilización. Las más comunes están fabricadas en chapa de acero estampado. Otros tipos se fabrican con latón o, en el caso en el cual se verifique una aplicación que implique altas velocidades, con resinas poliamídicas reforzadas.

TRATAMIENTO TÉRMICO

Generalmente los rodamientos pueden soportar temperaturas máximas de +120°C. Si este límite se supera los rodamientos deben ser sometidos a tratamientos térmicos especiales. Los rodamientos cerrados, tipo 2RS, se deberían utilizar a temperaturas máximas de +80°C. Si la temperatura supera este límite, la eficacia de los lubricantes y de las juntas se reduce mucho.

MATERIALS USED DURING THE CONSTRUCTION OF BEARINGS

Both the rings and the rolling elements of the bearings, are subjected to high stress on a very small contact surface; for this reason they must have a high resistance to wear and to fatigue. On that account bearings are made of very high quality carbon chromium steel. In accordance with SAE 52100-CR6, please find below table describing chemical composition. These bearings can be manufactured, under request, **in stainless steel**.

CAGE MATERIALS

Different types of cages are determined by the operative conditions. The most common are made of pressed steel. For high speeds applications, reinforced polyamid cages are manufactured; for other employment brass cages are used.

HEAT TREATMENT

Bearings are usually able to stand a maximum temperature of +120°C. In the case of higher temperature, bearings with special heat treatments should be used. Sealed bearings, 2RS type, should be used at operating temperatures up to +80°C.

If the temperature is higher, the efficacy of lubricants and seals is considerably reduced.

Composición química del acero para cojinetes
Chemical content of bearing steel

Estado Country	Símbolo Symbol	C %	Si	Mn	P	S	Cr	Ni	Mo
Alemania Germany	105Cr4	1.00-1.10	0.15-0.35	0.25-0.40	≤0.030	≤0.025	0.90-1.15	-	-
Alemania Germany	100Cr6	0.90-1.05	0.15-0.35	0.25-0.40	≤0.025	≤0.025	1.40-1.65	-	-
	100CrMn6	0.90-1.05	0.50-0.70	1.00-1.20	≤0.025	≤0.020	1.40-1.65	-	-
USA USA	E51100	0.98-1.10	0.20-0.35	0.25-0.45	≤0.025	≤0.025	0.90-1.15	≤0.025	≤0.08
USA USA	E52100	0.98-1.10	0.20-0.35	0.25-0.45	≤0.025	≤0.025	1.30-1.60	≤0.025	≤0.08
	485Gr.5	0.98-1.10	0.20-0.35	1.05-1.35	≤0.025	≤0.025	1.90-1.40	≤0.025	0.45-0.65
Japón Japan	SUJ 2	0.95-1.10	0.15-0.35	≤0.50	≤0.025	≤0.025	1.30-1.80	≤0.025	≤0.08
Japón Japan	SUJ 3	0.95-1.10	0.40-0.70	0.90-1.15	≤0.025	≤0.025	0.90-1.20	≤0.025	≤0.08

LUBRICACIÓN DE LOS RODAMIENTOS

La seguridad operativa y la durabilidad nominal de servicio de los rodamientos dependen del tipo de lubricante y del método de lubricación. La lubricación de los rodamientos tiene las siguientes finalidades:

- reducir, en fase de funcionamiento, el roce entre los cuerpos envolventes, la jaula y los aros de rodadura;
- reducir, entre ciertos límites, el nivel de ruido de funcionamiento de los rodamientos;
- garantizar a los rodamientos protección contra la corrosión.

Los lubricantes para rodamientos deben responder a los siguientes requisitos:

- resultar estables a nivel físico y químico;
- resultar libres de cuerpos extraños procedentes de los componentes mecánicos (como abrasivos, sustancias metálicas, etc);
- presentar un coeficiente mínimo de fricción;
- no ser corrosivos;
- presentar una buena capacidad lubricante.

Para los rodamientos se emplean dos categorías de lubricantes:

- lubricantes fluidos (aceites);
- lubricantes sólidos/plásticos (grasas);

Los lubricantes estándares empleados son Chevron SRI-2 o Shell Alvania2

En la elección del lubricante el coeficiente de viscosidad se deberá aumentar proporcionalmente a las dimensiones del rodamiento y a los valores de carga y de temperatura.

BEARINGS LUBRICATION

Safe operating life and long rating life of a bearing depends on the type of lubricant and on the lubrication method. Bearings lubrication has the following purposes:

- *to reduce friction between elements, cage and reaway during operation;*
- *to reduce, within certain limits, the noise in bearings;*
- *to grant anticorrosive protection to bearings.*

Lubricants for bearings have to satisfy the following requirements:

- *they should have physical and chemical stability;*
- *they should be free from foreign mechanical substances such as abrasive, metallic substances and so on;*
- *they should have a minimal coefficient of friction;*
- *they should not be corrosive;*
- *they should have a good lubrication capacity.*

Two categories of lubricants are used for bearing lubrication:

- *fluid lubricants (oils);*
- *plastic lubricants (greases).*

Bearings are supplied with Chevron SRI-2 or Shell Alvania2 grease

Concerning the choice of a lubricant, the viscosity factor must be directly and proportionally increased respect to bearing size, value of load and temperature.

GRASAS DISPONIBLES BAJO DEMANDA

LUBRICANTS AVAILABLE UNDER REQUEST

Fabricante <i>Producer</i>	Marca <i>Brand</i>	Origen <i>Base oil</i>	Punto de goteo °C <i>Drop point °C</i>	Consistencia <i>Consistency</i>	Temperatura se servicio °C <i>Operating temperature range °C</i>	Aplicación <i>Application</i>
Exxon	Beacon 325	Grasa sintética <i>Synthetic grease</i>	193	290	-60 ~ +120	Baja temperatura <i>Low temperature</i>
	Andok B	Mineral <i>Mineral</i>	260	280	-40 ~ +120	Genérica <i>General purpose</i>
	Andok C	Mineral <i>Mineral</i>	≥ 260	205	-20 ~ +120	Genérica <i>General purpose</i>
	Andok 260	Mineral <i>Mineral</i>	200	250	-30 ~ +150	Genérica <i>General purpose</i>
Kyodo Yushi	Multemp PS2	Diester <i>Diester</i>	189	280	-50 ~ +110	Baja temperatura <i>Low temperature</i>
	Multemp SRL	Ester <i>Ester</i>	191	245	-40 ~ +150	Bajo nivel de ruido <i>Low noise</i>
	Multemp SRH	Ester <i>Ester</i>	250	201	-40 ~ +150	Baja temperatura <i>Low temperature</i>
	Multemp SB-M	Aceite sintético <i>Synthetic oil</i>	220	260	-40 ~ +200	Alta velocidad y temperaturas <i>High speed and temperature</i>
	ET-K	Aceite sintético <i>Synthetic oil</i>	260	300	-40 ~ +200	Alta temperatura <i>High temperature</i>
Kluber	Asonic GLY32	Sintético <i>Synthetic</i>	190	265-295	-50 ~ +140	Baja temperatura <i>Low temperature</i>
	Asonik GHY72	Ester mineral <i>Ester Mineral</i>	250	250-280	-40 ~ +180	Alta temperatura y bajo nivel de ruido <i>High temperature and low noise</i>
	Isoflex Super LDS18	Diester <i>Diester</i>	190	280	-60 ~ +130	Baja temperatura <i>Low temperature</i>
	Isoflex LDS18 Special A	Diester <i>Diester</i>	190	280	-60 ~ +130	Baja temperatura <i>Low temperature</i>
	Isoflex Topas NB52	Hidrocarburo sintético <i>Hydrocarbon synthetic</i>	204	280	-60 ~ +170	Baja y alta temperatura <i>Low and high temperature</i>
	Barrierta L55/2	Fluorado <i>Fluorinated</i>	—	280	-35 ~ +260	Baja y alta temperatura <i>Low and high temperature</i>
	Barrierta TK44N2	Silicona <i>Silicone</i>	—	—	-60 ~ +230	Baja y alta temperatura <i>Low and high temperature</i>
	Isoflex NCA15	Ester mineral <i>Ester Mineral</i>	180	265-295	-40 ~ +130	Alta velocidad <i>High speed</i>
	Asonic HQ72-102	Ester <i>Ester</i>	240	250-280	-40 ~ +180	Baja y alta temperatura y bajo nivel de ruido <i>Low and high temperature and low noise</i>
Dow Corning	Molykote 33M	Silicona <i>Silicone</i>	210	260	-70 ~ +180	Baja y alta temperatura <i>Low and high temperature</i>
	Molykote 44M	Silicona <i>Silicone</i>	204	260	-40 ~ +200	Alta temperatura <i>High temperature</i>
	Molykote 55M	Silicona <i>Silicone</i>	—	—	-55 ~ +165	Bajas temperaturas <i>Low temperature</i>
	Shell	Alvania No.2 = Gadus S2 V100 2	Mineral <i>Mineral</i>	182	272	-25 ~ +120
Alvania No.3 = Gadus S2 V100 3		Mineral <i>Mineral</i>	183	233	-20 ~ +135	Genérica <i>General purpose</i>
Alvania RA = Gadus S2 V100 2		Mineral <i>Mineral</i>	183	252	-25 ~ +120	Genérica <i>General purpose</i>
Alvania EP2 = Gadus S2 V220 2		Mineral <i>Mineral</i>	185	276	-10 ~ +100	Genérica <i>General purpose</i>
Dolium R = Gadus S3 T100 2		Mineral <i>Mineral</i>	238	281	-20 ~ +140	Genérica <i>General purpose</i>
Aero Shell No.5		Mineral <i>Mineral</i>	≥ 260	282	-10 ~ +130	Genérica <i>General purpose</i>
Aero Shell No.7		Mineral <i>Mineral</i>	≥ 260	288	-70 ~ +150	Baja temperatura <i>Low temperature</i>
Aero Shell RLQ2 = Gadus S5 V25Q 2,5		Mineral <i>Mineral</i>	195	266	-50 ~ +150	Bajo nivel de ruido y alta velocidad <i>Low noise and high speed</i>
Mobil Oil	Mobilux2	Mineral <i>Mineral</i>	190	280	-20 ~ +120	Genérica <i>General purpose</i>
	Mobil 22	Mineral Diester <i>Diester Mineral</i>	192	274	-50 ~ +140	Baja temperatura <i>Low temperature</i>
	Mobil 28	Hidrocarburo sintético <i>Hydrocarbon synthetic</i>	≥ 260	280	-60 ~ +180	Baja y alta temperatura <i>Low and high temperature</i>
	Mobiltemp SHC22	Aceite sintético <i>Synthetic oil</i>	250	265-295	-50 ~ +180	Alta velocidad y temperatura <i>High speed and temperature</i>
	Mobiltemp SHC100	Aceite sintético <i>Synthetic oil</i>	250	265-295	-40 ~ +200	Alta velocidad y temperatura <i>High speed and temperature</i>
Du Pont	Krytox 240AC	Fluorado <i>Fluorinated</i>	—	282	-35 ~ +280	Alta temperatura <i>High temperature</i>
Caltex	Chevron SRI-2	Mineral <i>Mineral</i>	—	293	-30 ~ +175	Alta temperatura <i>High temperature</i>
Hangu	Hangu#2	Mineral <i>Mineral</i>	—	—	-20 ~ +120	Genérica <i>General purpose</i>

PAQUETES - EMBALAJES

- Paquetes individuales Todos los rodamientos **ISB**® se pueden suministrar en paquetes individuales, dentro de cajas de cartón, en bloques de celofán o en cajones de madera, según la dimensión del rodamiento.
- Paquetes industriales. Cuando los rodamientos se emplean en grandes cantidades en las líneas de montaje pueden ser solicitados en paquetes industriales y sueltos, protegidos por hojas de nylon o tubos de plástico, en cajas de cartón, que pueden contener diferentes cantidades (incluso centenares) según las dimensiones del rodamiento.
- Embalaje para el transporte. Las cajas de los rodamientos se apilan en general en pallets con flejes o dentro de grandes cajones de madera sobre pallets, para facilitar el transporte.

PACKING

- *Single packing* **ISB**® bearings can be supplied individually packed, inserted in carton boxes, rolled in cellophane; or in wooden cases, depending on bearing dimensions.
- *Industrial packing* This is the case of direct users, where bearings are requested in very big quantities to use on assembling lines. Under request they are delivered loose in a box, protected by nylon sheets or packed in plastic tubes and inserted therefore in carton boxes. These are able to contain different quantities, even hundreds, depending on bearing dimensions.
- *Transport packing* Bearing boxes are usually piled up on bound pallets or inserted in wooden cases rested on pallets to get he transport operations easier.



SUFIJOS DE LOS RODAMIENTOS

Z	Blindaje de metal de un lado del rodamiento
ZZ	Blindaje de metal de ambos lados del rodamiento
RS	Junta de goma de un lado del rodamiento
2RS	Junta de goma de ambos lados del rodamiento
N	Ranurado en el anillo externo para anillo bloqueo
NR	Ranurado en el anillo externo con anillo (de bloqueo)
M	Jaula de latón
MA	Jaula de latón centrada en el anillo externo
MB	Jaula de latón centrada en el anillo interno
TN	Jaula de poliamida reforzada
P6	Tolerancia clase ISO 6
P5	Tolerancia clase ISO 5
P4	Tolerancia clase ISO 4
C2	Juego inferior normal
C3	Juego superior normal
C4	Juego superior en el C3
C5	Juego superior en el C4
K	Orificio conico

BEARINGS SUFFIX

Z	<i>Metal shield at one side of the bearing</i>
ZZ	<i>Metal shields at both sides of the bearing</i>
RS	<i>Rubbing seal at one side of the bearing</i>
2RS	<i>Rubbing seals at both sides of the bearing</i>
N	<i>Snap ring groove in outer ring</i>
NR	<i>Snap ring groove in outer ring with stop ring</i>
M	<i>Machined brass cage</i>
MA	<i>Machined brass cage centred on the outer ring</i>
MB	<i>Machined brass cage centred on the inner ring</i>
TN	<i>Reinforced polyamid cage</i>
P6	<i>Accuracy to ISO tolerance class 6</i>
P5	<i>Accuracy to ISO tolerance class 5</i>
P4	<i>Accuracy to ISO tolerance class 4</i>
C2	<i>Radial clearance less than normal</i>
C3	<i>Radial clearance greater than normal</i>
C4	<i>Radial clearance greater than C3</i>
C5	<i>Radial clearance greater than C4</i>
K	<i>Conical bore</i>





Rodamientos rígidos de bolas

Radial deep groove ball bearings



RODAMIENTOS RÍGIDOS DE UNA HILERA DE BOLAS

ISB® produce diversos tipos de rodamientos rígidos de una hilera de bolas, identificados por específicas características técnicas y peculiares aplicaciones mecánicas. En virtud de las amplias posibilidades propuestas al comprador, los rodamientos rígidos de una hilera de bolas se pueden subdividir en tres grupos:

- Rodamientos estándar
- Rodamientos con juntas
- Rodamientos ranurados para el aro de fijación (con o sin aro de fijación).

Los rodamientos rígidos de una hilera de bolas, siendo estructuralmente simples y no desmontables, no presentan exigencias específicas de mantenimiento, además, se presentan resistentes y particularmente idóneos para prestaciones de velocidad elevada, resultando por este motivo fiables y versátiles en sus posibles aplicaciones mecánicas.

Los rodamientos rígidos de una hilera de bolas producidos por ISB®, contando con ranuras profundas y un elevado contacto, es decir un elevado coeficiente entre el radio del camino de rodadura y el diámetro de las bolas, pueden resistir, además de cargas radiales, requerimientos axiales en ambos sentidos.

En caso de aplicaciones especiales de rodamientos rígidos de una hilera, contactar con el servicio técnico ISB®. Para informaciones inherentes a rodamientos, en lo relativo a las dimensiones o características morfológicas, contactar con la oficina técnica ISB®.

RODAMIENTOS ESTÁNDAR

Los rodamientos base ISB® (Fig. 1) son abiertos, sin juntas.

SINGLE ROW DEEP GROOVE RADIAL BALL BEARINGS

ISB® produces various types of single row deep groove radial ball bearings, which differ in terms of specific technical characteristics and of peculiar mechanical applications. In view of the assortment offered to purchasers, the single row deep groove radial ball bearings can be split-up into three groups:

- Standard bearings
- Sealed bearings
- Bearings with snap ring grooves (with or without snap ring).

Seeing as the single row deep groove radial ball bearings are structurally simple and not separable, they do not involve any maintenance requirements in particular. They are resistant and particularly suited for high speed outputs and are consequently reliable and versatile in their possible mechanical applications.

Due to the fact that the single row deep groove radial ball bearings produced by ISB® have deep grooves and very close conformity, or rather a high ratio between the radius of the raceway and the diameter of the balls, they are able not only to withstand radial loads but also axial loads in both directions.

For special applications of the single row deep groove radial ball bearings, please contact the engineering department of ISB®. For information concerning the bearings with regard to sizes or morphologic specifications, please contact the application engineering department of ISB®.

STANDARD BEARING

The standard bearings of ISB® (Fig. 1) are open i.e. unsealed.

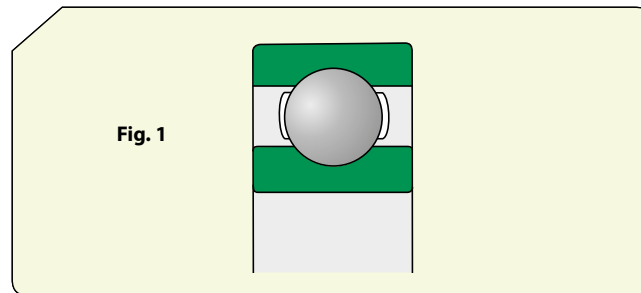

RODAMIENTOS CON JUNTAS INCLUIDAS

Las dimensiones más usuales se fabrican también para los rodamientos con juntas incluidas. Dicho tipo de rodamiento está lubricado de por vida y no necesita mantenimiento. El tipo de grasa lubricante varía según la dimensión, su grado de llenado es del 20/30% del espacio libre en el rodamiento. Para garantizar su correcto funcionamiento, los rodamientos no deben alcanzar temperaturas superiores a los 80° y no deben ser lavados.

La realización de los rodamientos especiales, con otros grados de llenado o la utilización de grasas especiales se efectúan y suministran previa solicitud.

SEALED BEARINGS

The most popular sizes of bearings are also produced for sealed bearings. This type of bearing is lubricated for life and requires no future maintenance. The type of lubricant grease varies based on the sizes and the filling grade is 20/30% of the free space in the bearing. To guarantee the correct use of the bearings, they should not be heated to temperatures beyond 80 °C and should not be washed.

Special bearings with other filling grades or ones with special grease can be produced and supplied on specific request.

RODAMIENTOS BLINDADOS

Se reconocen gracias a los sufijos Z y ZZ en el nombre. Los blindajes son de chapa de acero, su orificio crea un laberinto con la superficie cilíndrica externa del aro interno (**Fig. 2**).

Los rodamientos blindados se emplean en las aplicaciones en las que el aro interno gira. En el caso que gire el aro externo, se puede producir, sobre todo a altas velocidades, salida de grasa del rodamiento.

SHIELDED BEARINGS

*Shielded bearings are identified by the designation suffix Z and ZZ. The shields are made of sheet steel and their bore creates a labyrinth with the external cylindrical surface of the inner ring (**Fig. 2**).*

Shielded bearings are used primarily in applications where the inner ring rotates. If it is the outer ring that rotates, there is the risk that grease may leak from the bearing, especially at high speeds.

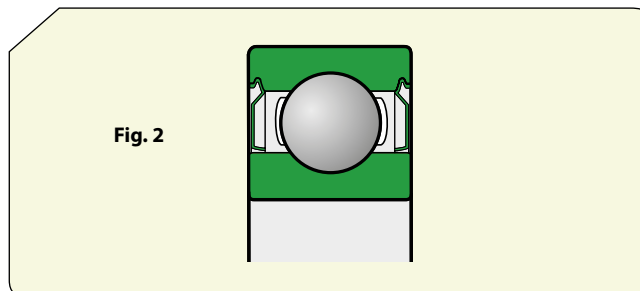

RODAMIENTOS CON BLINDAJES DE REDUCIDA FRICCIÓN.

Los rodamientos **ISB**[®] rígidos de bolas blindados con reducida fricción se identifican con los siguientes sufijos: RZ para rodamientos blindados de un solo lado, 2RZ para indicar aquellos con juntas en ambos lados (**Fig. 3**). Los blindajes son de goma acrilonitrilo-butadieno (NBR) y reforzados con una chapa. El NBR es resistente a los aceites y al desgaste. Los blindajes junto a la superficie cilíndrica externa del aro interno forman un espacio muy pequeño y son no deslizantes. Esta es la razón por la cual los rodamientos **ISB**[®] con blindajes de baja fricción tienen una durabilidad mayor y pueden trabajar a las mismas altas velocidades de los rodamientos blindados Z. Las temperaturas de utilización varían de -40°C a +100°C. Para breves períodos se puede alcanzar una temperatura máxima de +120°C.

BEARINGS WITH LOW-FRICTION SHIELDS

*The deep groove radial ball bearings of **ISB**[®] with low-friction shields are identified by the designation suffixes: RZ for ball bearings shielded just on one side, 2RZ for those with shields on both sides (**Fig. 3**). The shields are made of Nitrile-Butadiene-Rubber (NBR) with sheet steel reinforcement. This rubber is resistant to oil and wear. The shields form a very small gap with the external cylindrical surface of the inner ring and do not touch each other. This is why **ISB**[®] ball bearings with low-friction shields have a better seal and can work at the same speeds as the Z type shielded ball bearings. The operating temperatures vary from -40°C to +100°C. They can even work at a maximum temperature of +120°C but for short periods only.*

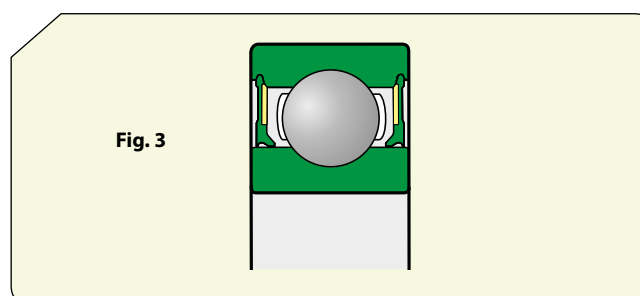

RODAMIENTOS CON BLINDAJES DESLIZANTES

Los sufijos indicativos de los rodamientos con blindaje deslizante son RS y 2RS (**Fig. 4**). El diámetro externo de las juntas está insertado en un ranurado de las caras del aro externo que lo retiene en posición sin deformaciones garantizando al mismo tiempo buenos resultados de durabilidad.

Como hemos visto para los rodamientos con blindajes de reducida fricción, las juntas de los RS y 2RS son de goma acrilonitrilo-butadieno (NBR) reforzadas con una chapa. Combinando el material de composición, las temperaturas de utilización serán las mismas, es decir de -40°C a +100°C con picos, sólo para períodos breves, que llegan hasta +120°C.

Velocidades, temperaturas demasiado elevadas u otras condiciones de trabajo difíciles pueden causar pérdidas de grasa de los labios.

BEARINGS WITH CONTACT SHIELDS

*The ball bearings with contact shields are identified with designation suffix RS and 2RS (**Fig. 4**). The outside diameter of the seals sits in a recess in the outer ring that holds it in position without deforming it, providing a good seal at the same time.*

Likewise for the ball bearings with low-friction shields, the RS and 2RS seals are made of Nitrile-Butadiene-Rubber (NBR) with sheet steel reinforcement. Sharing the same composition material, the operating temperatures will be the same, in other words from -40°C to +100°C with peaks up to +120°C for short periods only.

Excessive speeds and temperatures or other harsh working conditions could cause grease to leak from the inner rings.

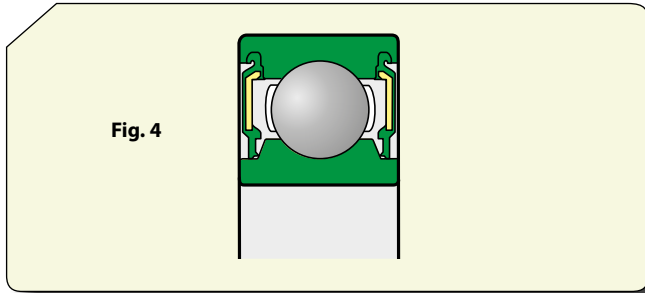
Fig. 4
RODAMIENTOS CON UN RANURADO PARA ARO DE FIJACIÓN

Los rodamientos **ISB**[®] rígidos de una hilera de bolas con ranurado para aro de fijación se suministran en las siguientes versiones:

- Abiertos, N es el sufijo en el nombre (**Fig. 5a**);
- Abiertos con aro de fijación, NR es el sufijo en el nombre (**Fig. 5b**);
- Con junta Z en el lado opuesto al ranurado y aro de fijación, ZNR es el sufijo en el nombre (**Fig. 5c**);
- Con juntas Z en ambos lados y aro de fijación, 2ZNR es el sufijo en el nombre (**Fig. 5d**).

BEARINGS WITH ONE SNAP RING GROOVE

ISB[®] single row deep groove radial ball bearings with one snap ring groove are supplied in the following versions:

- Open, N being the designation suffix (**Fig. 5a**);
- Open with snap ring, NR being the designation suffix (**Fig. 5b**);
- With Z shield on the side opposite the groove and with snap ring, ZNR being the designation suffix (**Fig. 5c**);
- With Z shield on both sides and with snap ring, 2ZNR being the designation suffix (**Fig. 5d**).

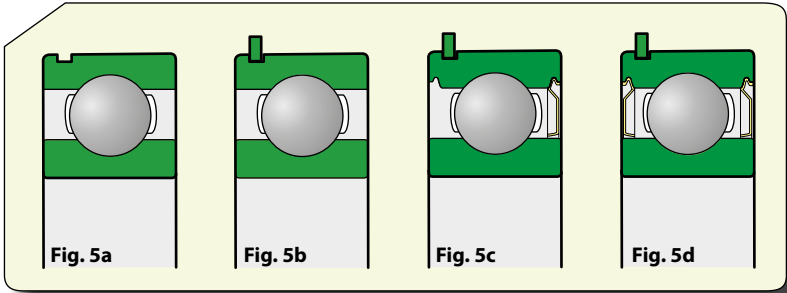
Fig. 5a
Fig. 5b
Fig. 5c
Fig. 5d

Estos tipos de rodamientos simplifican el proyecto ya que permiten la retención en sentido axial en el alojamiento mediante un aro de fijación o de retención (**Fig. 6**), garantizando al mismo tiempo un ahorro en términos de espacio. En la tabla de los productos se expone, además de los rodamientos, los nombres y las dimensiones de los aros de fijación, porque los mismos se podrán suministrar por separado o bien ya montados.

*These types of bearings simplify the project because they can be detained axially in the housing by a snap ring or retaining ring (**Fig. 6**), which also saves space. In the product table, together with the bearings, the designations and the dimensions of the snap rings are also given, because they may be supplied separately or already fitted on the bearing.*

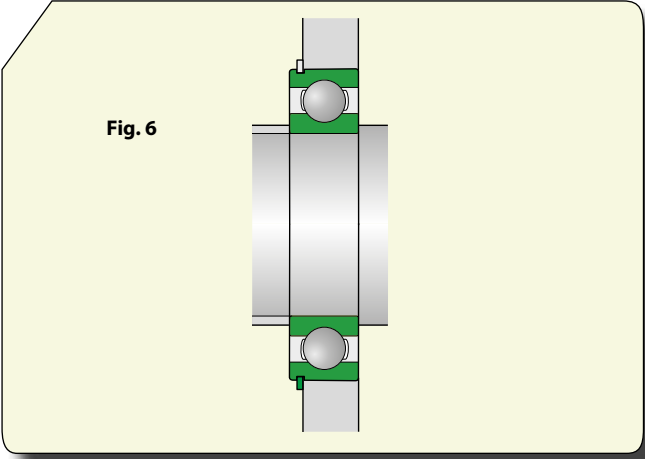
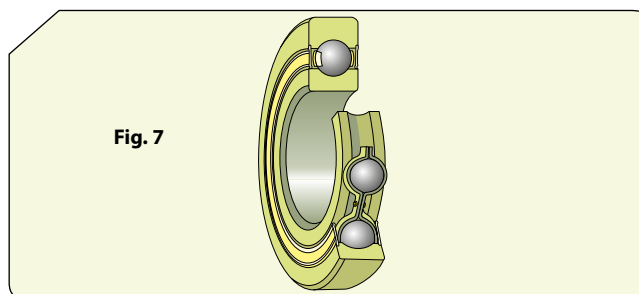

Fig. 6

RODAMIENTOS DE BOLAS SELLADOS

Los rodamientos de bolas sellados (**Fig.7**) se basan en los rodamientos rígidos de bolas de la serie 62.

SEALED BALL BEARINGS

The sealed ball bearings (**Fig.7**) are based on series 62 deep groove ball bearings.



Presentan una superficie de rotación convexa y cuentan, en ambos lados, con juntas deslizantes de goma acrilonitrilo-butadieno (NBR) reforzadas con chapa.

Se suministran listos para el montaje y pre-engrasados. Gracias a su superficie de rotación convexa pueden ser utilizados en aplicaciones en las cuales resulte probable una desalineación angular respecto al camino de rodadura, y en aquellas donde sea necesario reducir al mínimo las sollicitaciones periféricas.

They have a crowned rolling surface and have sliding shields in Nitrile-Butadiene-Rubber (NBR) with sheet steel reinforcement on both sides.

They are supplied ready for assembly and pre-greased. Thanks to their crowned rolling surface they can be used in applications where there is a probable angular misalignment compared to the raceway and where peripheral strain must be minimised.

DIMENSIONES

Las dimensiones generales de los rodamientos **ISB**[®] rígidos de una hilera de bolas respetan la norma ISO 15:1998.

DIMENSIONS

The overall dimensions of **ISB**[®] single row deep groove radial ball bearings comply with standard ISO 15:1998.

TOLERANCIAS

Los rodamientos rígidos de una hilera de bolas **ISB**[®] se fabrican de conformidad con las tolerancias normales. Los valores de las tolerancias respetan la norma ISO 492:2002.

ISB[®], específicamente para los sistemas de rodamientos en los cuales la precisión resulta un factor determinante, produce algunos con grados de precisión conforme a las clases P6 o P5. Si Usted desea solicitar estos rodamientos rígidos de bolas particulares contacte con la oficina técnica.

TOLERANCES

ISB[®] single row deep groove radial ball bearings are manufactured pursuant to Normal tolerances. The tolerance values comply with standard ISO 492:2002.

For bearing arrangements where precision is the key factor, **ISB**[®] produces some specific bearings with precision pursuant to class P6 or P5. If you wish to order these special types of deep groove radial ball bearings, please contact the application engineering department.

JUEGO INTERNO

Los valores de juego interno radial se indican en la tabla expuesta en la introducción, respetan la norma ISO 5753:1991 y se refieren a rodamientos no montados y carga de medida cero.

Los rodamientos **ISB**[®] rígidos de una hilera de bolas se fabrican generalmente con juego interno radial denominado Normal. Una parte de los rodamientos se suministran con juegos radiales internos diferentes del estándar: C2 menores de la medida normal, C3, C4 y C5 mayores. Estas cuatro variantes están disponibles previa solicitud.

INTERNAL CLEARANCE

The internal radial clearance values are indicated in the table given in the introduction and comply with standard ISO 5753:1991: They refer to unfitted bearings with zero measuring load.

ISB[®] single row deep groove radial ball bearings are usually manufactured with Normal internal radial clearance. Some of the bearings are supplied with non-standard internal radial clearances: C2 smaller than normal clearance, C3, C4 and C5 greater. These four variants are supplied on specific request.

DESALINEACIÓN

La desalineación angular admisible, es decir aquella desalineación que no genera ulteriores sollicitaciones inaceptables depende de cuatro factores:

- juego interno radial del rodamiento en las condiciones de servicio;
- dimensiones;
- forma constructiva interna;
- cargas y movimientos a los que está sujeto.

MISALIGNMENT

The admitted angular misalignment, being a misalignment that does not produce unacceptable additional strain, depends on four factors:

- The internal radial clearance of the bearing in the operating conditions.
- The size of the bearing.
- The internal constructional design.
- The loads and the movements acting on the bearing.

Cada desalineación produce pérdida de silenciosidad y reducción de la vida del rodamiento; no es posible hacer una tabla con valores específicos de referencia porque las relaciones que interesan los citados factores son muy complejas.

JAULAS

En base a las diversas dimensiones, serie y diseños son siete las jaulas con las que cuentan los rodamientos ISB® rígidos de una hilera de bolas:

- obtenidas a partir de cinta, en chapa de acero, centradas en las bolas, ningún sufijo en el nombre (**Fig. 8a**);
- obtenidas a partir de cinta, en latón, centradas en las bolas, Y es el sufijo en el nombre;
- remachadas, en chapa de acero, centradas en las bolas, ningún sufijo en el nombre (**Fig. 8b**);
- remachadas, en latón, centradas en las bolas, Y es el sufijo en el nombre;
- mecanizadas de latón, centradas en las bolas, M es el sufijo en el nombre (**Fig. 8c**);
- mecanizadas de latón, centradas en el aro externo, M es el sufijo en el nombre;
- moldeadas por inyección, a presión, en poliamida 6.6 reforzada en fibra de vidrio, centradas en las bolas, TN9 es el sufijo en el nombre (**Fig. 8d**);

Los rodamientos con jaulas de chapa estampada en diseño normal están disponibles también en las otras versiones con jaulas mecanizadas de latón o moldeadas por inyección, a presión de poliamida 6.6.

Misalignment will result in increased noise of the bearing and will reduce its life span. It is impossible to draft a table with the specific reference values because the relationships between these four factors just mentioned are too complex.

CAGES

Based on the various sizes, series and versions, ISB® single row deep groove radial ball bearings are fitted with one of the following cages:

- pressed ribbon-type steel cage, centred on the balls, without any designation suffix (**Fig. 8a**);
- pressed ribbon-type brass cage, centred on the balls, with designation suffix Y;
- riveted pressed steel cage, centred on the balls, without any designation suffix (**Fig. 8b**);
- riveted pressed brass cage, centred on the balls, with designation suffix Y;
- Solid machined brass cage, centred on the balls, with designation suffix M (**Fig. 8c**);
- Solid machined brass cage, centred on the outer ring, with designation suffix MA;
- injection moulded snap-type cage made of polyamide 6.6 with fibreglass reinforcement, centred on the balls, with designation suffix TN9 (**Fig. 8d**);

Standard ball bearings with pressed steel cage are also available in other versions with solid machined brass or injection moulded snap-type cages made of polyamide 6.6.

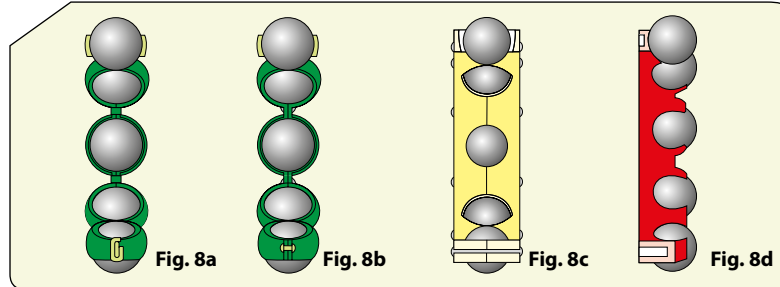

Los rodamientos TN9 pueden ser utilizados hasta temperaturas que alcanzan los +120°C.

Atención al utilizar aceites sintéticos, grasa a base de aceite sintético y lubricantes con alto porcentaje de aditivos EP si se utiliza a altas temperaturas, podrían dañar las jaulas.

CARGA MÍNIMA

Necesaria para garantizar un funcionamiento correcto. Todos los rodamientos envoltentes deben estar sujetos a una cierta carga mínima. En los casos en que exista rotación a altas velocidades, aceleraciones elevadas o repentinos cambios de dirección, las fuerzas de inercia de las bolas y de las jaulas, la fricción del lubricante, influyen negativamente sobre las condiciones del sistema rodamiento, provocando deslizamientos perjudiciales entre bolas y aros.

TN9 bearings can be used for temperatures up to +120°C.

Beware when using synthetic oil, synthetic oil-based grease and lubricants with high percentage of EP additives if used at high temperatures, as they could damage the cages.

MINIMUM LOAD

This is required to guarantee efficient operation. All rolling bearings must be subjected to a certain minimum load. If they are to operate at high rotation speeds, high accelerations or sudden changes in direction, the inertia forces of the balls and of the cages and the friction of the lubricant have a detrimental effect on the conditions of the bearing arrangement and may cause harmful contact between the balls and the raceways.

CAPACIDAD CARGA AXIAL

La carga axial pura no puede superar $0.5 C_0$. En los rodamientos de pequeñas dimensiones (diámetros hasta aprox. 12 mm) y en aquellos de las series ligeras (serie diametrales 8, 9, 0, y 1), el correspondiente límite es $0,25 C_0$. Cargas axiales excesivas pueden reducir notablemente la durabilidad del rodamiento.

DESIGNACIONES SUPLEMENTARIAS

Los sufijos utilizados para identificar algunas características de los rodamientos rígidos de bolas **ISB**[®] son los siguientes:

C2	Juego radial interno inferior al Normal
C3	Juego radial interno mayor al Normal
C4	Juego radial interno mayor que C3
C5	Juego radial interno mayor que C4
J	Jaula estampada de acero
M	Jaula mecanizada de latón centrada en las bolas
MA	Jaula mecanizada de latón, centrada en el aro externo
MB	Jaula mecanizada de latón, centrada en el aro interno
N	Ranurado para anillo elástico en el aro externo
NR	Ranurado para anillo elástico en el aro externo, con anillo elástico
P5	Precisión dimensional y de rotación según la clase de tolerancia 5 de la norma ISO
P6	Precisión dimensional y de rotación según la clase de tolerancia 6 de la norma ISO
P52	P5 + C2
P62	P6 + C2
P63	P6 + C3
RS	Obturación de goma acrílonitrilo-butadieno (NBR) con refuerzo de chapa estampada, de un lado del rodamiento
RZ	Obturación con reducida fricción de goma acrílonitrilo-butadieno (NBR) con refuerzo de chapa estampada, de un lado del rodamiento
TN	Jaula moldeada por inyección de poliamida
TN9	Jaula moldeada por inyección de poliamida 6,6 reforzada con fibras de vidrio
Y	Jaula moldeada de latón
Z	Blindaje de chapa moldeada (obturación no deslizante), de un lado del rodamiento
ZNR	Ranurado para anillo elástico en el aro externo, con anillo elástico y blindaje de chapa del lado opuesto del ranurado
2RS	Obturación de goma acrílonitrilo-butadieno (NBR) con refuerzo de chapa, en ambos lados del rodamiento
2RZ	Obturación con reducida fricción de goma acrílonitrilo-butadieno (NBR) con refuerzo de chapa estampada, de ambos lados del rodamiento
ZZ	Blindaje Z de ambos lados del rodamiento
ZZNR	Ranurado para anillo elástico en el aro externo, con anillo elástico y blindajes de chapa estampada de ambos lados del rodamiento

AXIAL LOAD CARRYING CAPACITY

The pure axial load must not exceed $0.5 C_0$. For small bearings (diameters up to approximately 12 mm) and light series bearings (diameter series 8, 9, 0, and 1), the corresponding limit is $0,25 C_0$. Excessive axial loads may considerably reduce the bearing life span.

SUPPLEMENTARY DESIGNATIONS

The designation suffixes used to identify certain characteristics of **ISB**[®] deep groove radial ball bearings are the following:

C2	Internal radial clearance smaller than Normal
C3	Internal radial clearance greater than Normal
C4	Internal radial clearance greater than C3
C5	Internal radial clearance greater than C4
J	Pressed steel cage
M	Solid machined brass cage, centred on the balls
MA	Solid machined brass cage, centred on the outer ring
MB	Solid machined brass cage, centred on the inner ring
N	Groove for snap ring on outer ring
NR	Groove for snap ring on outer ring, with snap ring
P5	Dimensional and rotation precision pursuant to tolerance class 5 of ISO standard
P6	Dimensional and rotation precision pursuant to tolerance class 6 of ISO standard
P52	P5 + C2
P62	P6 + C2
P63	P6 + C3
RS	Nitrile-Butadiene-Rubber (NBR) seal with pressed sheet steel reinforcement, on one side of the bearing
RZ	Nitrile-Butadiene-Rubber (NBR) low friction seal with pressed sheet steel reinforcement, on one side of the bearing
TN	Injection moulded cage of polyamide
TN9	Injection moulded cage of polyamide 6.6 with fibreglass reinforcement
Y	Pressed brass cage
Z	Pressed sheet steel shield (no contact seal) on one side of the bearing
ZNR	Groove for snap ring on outer ring, with snap ring and sheet steel shield opposite the groove
2RS	Nitrile-Butadiene-Rubber (NBR) seal with sheet steel reinforcement, on both sides of the bearing
2RZ	Nitrile-Butadiene-Rubber (NBR) low friction seal with pressed sheet steel reinforcement, on both sides of the bearing
ZZ	Z shield on both sides of the bearing
ZZNR	Groove for snap ring on outer ring with snap ring and pressed sheet steel shields on both sides of the bearing





Microrrodamientos rígidos de bolas

Miniature radial ball bearings

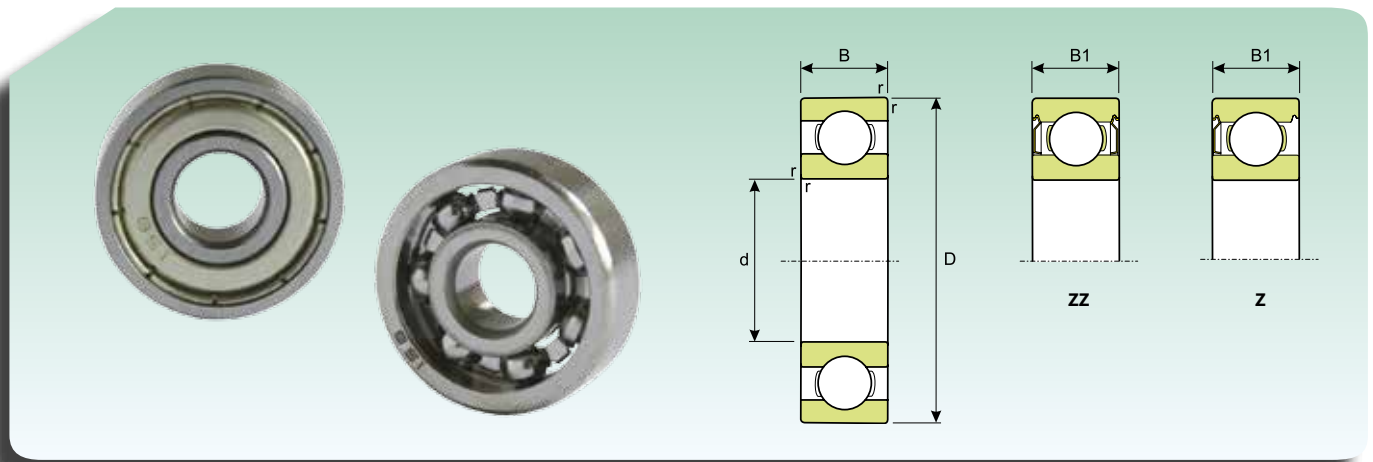

MICRORODAMIENTOS RÍGIDOS DE BOLAS (serie métrica)
MINIATURE RADIAL BALL BEARINGS (metric series)

Dimensiones Dimension					Coeficiente de carga (kN) Load rating (kN)		Sigla Designation	
d (mm)	D (mm)	r (mm)	B (mm)	B1 (mm)	Dinámico Dynamic C	Estático Static C ₀	Abierto Open	Blindado Shielded
1	3	0.05	1	-	0.075	0.025	681	-
	3	0.1	1.5	-	0.075	0.025	MR31	-
	4	0.1	1.6	-	0.075	0.025	691	-
1.2	4	0.1	1.8	2.5	0.085	0.03	MR41X	MR41XZZ
1.5	4	0.15	1.2	2	0.085	0.03	681X	681XZZ
	5	0.1	2	2.6	0.13	0.045	691X	691XZZ
	6	0.1	2.5	3	0.25	0.10	601X	601XZZ
2	5	0.1	1.5	2.3	0.13	0.045	682	682ZZ
	5	0.1	2	2.5	0.13	0.045	MR52	MR52ZZ
	6	0.15	2.3	3	0.25	0.10	692	692ZZ
	6	0.15	2.5	2.5	0.25	0.10	MR62	MR62ZZ
	7	0.15	2.5	3	0.30	0.15	MR72	MR72ZZ
	7	0.15	2.8	3.5	0.30	0.15	602	602ZZ
2.5	6	0.15	1.8	2.6	0.16	0.06	682X	682XZZ
	7	0.15	2.5	3.5	0.30	0.15	692X	692XZZ
	8	0.2	2.5	-	0.43	0.19	MR82X	MR82XZZ
	8	0.15	2.8	4	0.43	0.19	602X	602XZZ
3	6	0.1	2	2.5	0.16	0.06	MR63	MR63ZZ
	7	0.15	2	3	0.24	0.10	683	683ZZ
	8	0.15	2.5	3	0.43	0.19	MR83	MR83ZZ
	8	0.15	3	4	0.43	0.19	693	693ZZ
	9	0.2	2.5	4	0.44	0.19	ME93	ME93ZZ
	9	0.15	3	5	0.44	0.19	603	603ZZ
4	13	0.3	5	5	1.01	0.49	633	633ZZ
	7	0.1	2	2.5	0.16	0.06	MR74	MR74ZZ
	8	0.15	2	3	0.30	0.12	MR84	MR84ZZ
	9	0.15	2.5	4	0.49	0.22	684	684ZZ
	10	0.2	3	4	0.45	0.19	MR104	MR104ZZ
	11	0.15	4	4	0.55	0.25	694	694ZZ
5	12	0.2	4	4	0.74	0.35	604	604ZZ
	8	0.1	2	2.5	0.21	0.10	MR85	MR85ZZ
	9	0.15	2.5	3	0.33	0.14	MR95	MR95ZZ
	10	0.15	3	4	0.33	0.14	MR105	MR105ZZ
	11	0.15	-	4	0.55	0.25	-	MR115ZZ
	11	0.15	3	5	0.55	0.25	685	685ZZ
	13	0.2	4	4	0.83	0.40	695	695ZZ
	14	0.2	5	5	1.02	0.49	605	605ZZ
6	10	0.15	2.5	3	0.38	0.18	MR106	MR106ZZ
	12	0.2	3	4	0.55	0.25	MR126	MR126ZZ
	13	0.15	3.5	5	0.83	0.40	686	686ZZ
	15	0.2	5	5	1.03	0.49	696	696ZZ
	17	0.3	6	6	1.53	0.75	606	606ZZ
	22	0.3	7	7	2.56	1.38	636	636ZZ

MICRORODAMIENTOS RÍGIDOS DE BOLAS (serie métrica)
MINIATURE RADIAL BALL BEARINGS (metric series)

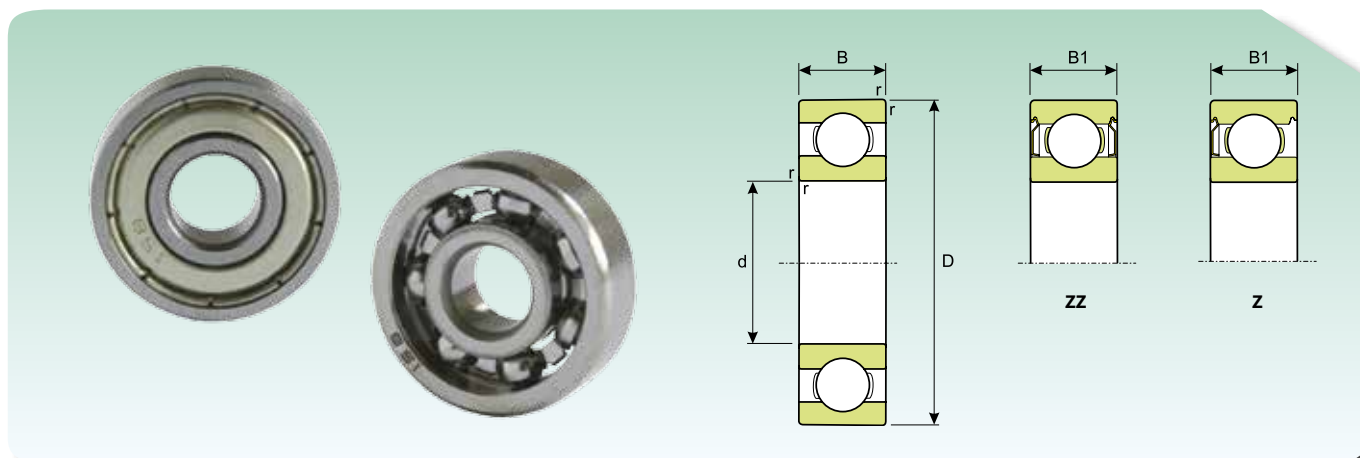

Dimensiones Dimension					Coeficiente de carga (kN) Load rating (kN)		Sigla Designation	
d (mm)	D (mm)	r (mm)	B (mm)	B1 (mm)	Dinámico Dynamic C	Estático Static C ₀	Abierto Open	Blindado Shielded
7	11	0.15	2.5	3	0.35	0.16	MR117	MR117ZZ
	13	0.2	3	4	0.42	0.21	MR137	MR137ZZ
	14	0.15	3.5	5	0.91	0.45	687	687ZZ
	17	0.3	5	5	1.24	0.64	697	697ZZ
8	12	0.15	2.5	3.5	0.42	0.21	MR128	MR128ZZ
	14	0.2	3.5	4	0.63	0.31	MR148	MR148ZZ
	16	0.2	4	5	0.97	0.50	688	688ZZ
	19	0.3	6	6	1.73	0.88	698	698ZZ
	24	0.3	8	8	2.58	1.38	628	628ZZ
	28	0.3	9	9	3.54	1.99	638	638ZZ
9	17	0.2	4	5	1.03	0.55	689	689ZZ
	20	0.3	6	6	1.92	1.01	699	699ZZ
	24	0.3	7	7	2.60	1.38	609	609ZZ
	26	0.6	8	8	3.54	1.99	629	629ZZ

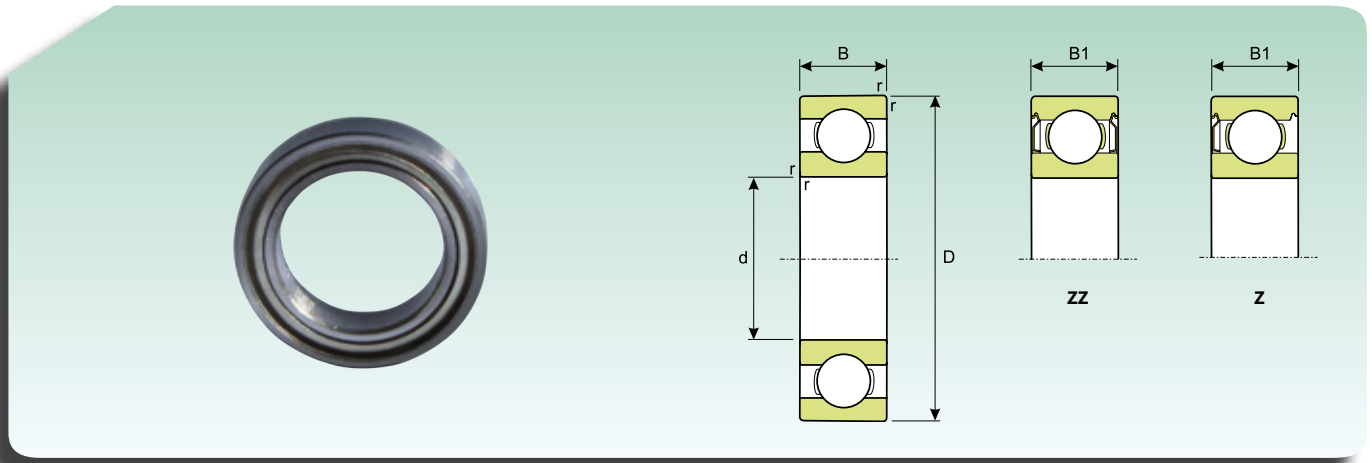
MICRORRODAMIENTOS RÍGIDOS DE BOLAS (serie métrica)
MINIATURE RADIAL BALL BEARINGS (metric series)

Dimensión Dimension				Coeficiente de carga (KN) Load rating (KN)		Velocidad límite (rpm) Speed limit (Rpm)		Sigla Designation	
d (mm)	D (mm)	r (mm)	B (mm)	Dinámico Dynamic C	Estático Static C ₀	Lubrificación Lubrication		Abierto Open	Blindado Shielded
						Grasa Grease	Aceite Oil		
10	15	0.15	3	66	34	36000	43000	61700	-
	15	0.15	4	66	34	36000	43000	-	61700ZZ
	19	0.3	7	133	56	34000	40500	613800	613800ZZ
12	18	0.2	4	72	41	31000	37000	61701	61701ZZ
	21	0.3	7	149	68	30500	36000	613801	613801ZZ
15	21	0.2	4	81	44	27000	32000	61702	61702ZZ
	24	0.3	7	162	79	26000	31500	613802	613802ZZ
17	23	0.2	4	80	50	25000	30000	61703	61703ZZ
	26	0.3	7	175	90	24000	29500	613803	613803ZZ
20	27	0.2	4	84	57	21000	25000	61704	61704ZZ
25	32	0.2	4	90	66	19000	23000	61705	61705ZZ
30	37	0.2	4	95	76	17000	20000	61706	61706ZZ
35	44	0.3	5	155	130	14000	17000	61707	61707ZZ
40	50	0.3	6	207	177	13000	16000	61708	61708ZZ
45	55	0.3	6	213	192	12000	14000	61709	61709ZZ

MICRORRODAMIENTOS RÍGIDOS DE BOLAS CON BRIDAS (serie métrica)
MINIATURE RADIAL BALL FLANGED BEARINGS (metric series)

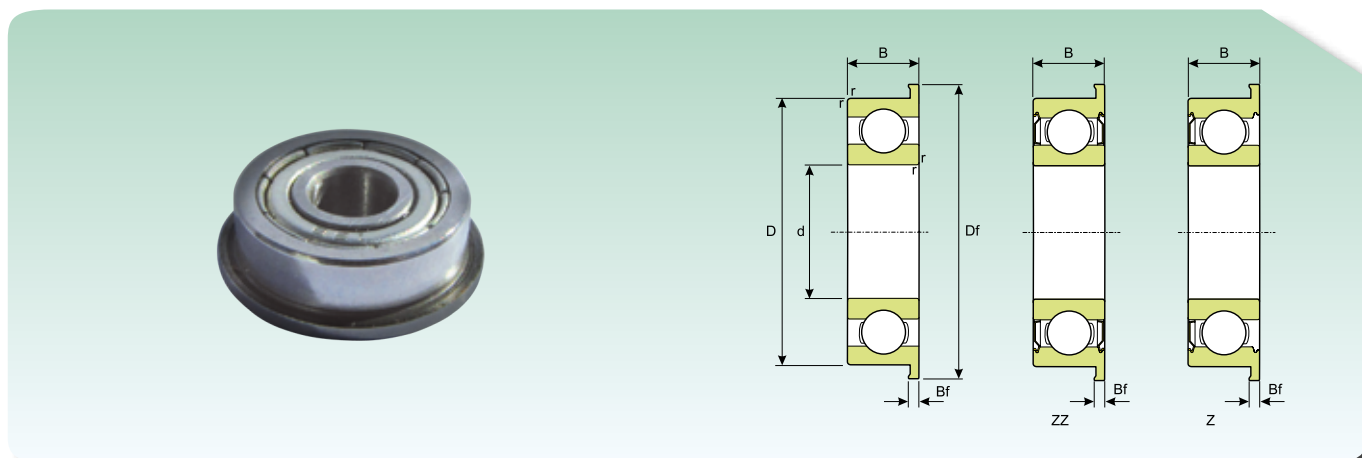

Dimensión Dimension						Coeficiente de carga (KN) Load rating (KN)		Sigla Designation	
d (mm)	D (mm)	Df (mm)	r (mm)	B (mm)	Bf (mm)	Dinámico Dynamic C	Estático Static C ₀	Abierto Open	Blindado Shielded
1	3	3.8	0.05	1	0.3	0.075	0.025	F681	-
	4	5	0.1	1.6	0.5	0.075	0.025	F691	-
1.2	4	4.8	0.1	1.8	0.4	0.085	0.03	FM41X	-
1.5	4	5	0.15	1.2	0.4	0.085	0.03	F681X	F681XZZ
	5	6.5	0.1	2	0.6	0.13	0.045	F691X	F691XZZ
	6	7.5	0.1	2.5	0.6	0.25	0.010	F601X	F601XZZ
2	5	6.1	0.1	1.5	0.5	0.13	0.045	F682	F682ZZ
	5	6.2	0.1	2	0.6	0.13	0.045	MF52	MF52ZZ
	6	7.5	0.15	2.3	0.6	0.25	0.10	F692	F692ZZ
	6	7.2	0.15	2.5	0.6	0.25	0.10	MF62	MF62ZZ
	7	8.2	0.15	2.5	0.6	0.30	0.15	MF72	MF72ZZ
	7	8.5	0.15	2.8	0.7	0.30	0.15	F602	F602ZZ
2.5	6	7.1	0.15	1.8	0.5	0.16	0.06	F682X	F682XZZ
	7	8.5	0.15	2.5	0.7	0.30	0.15	F692X	F692XZZ
	8	9.2	0.2	2.5	0.6	0.43	0.19	MF82X	MF82XZZ
	8	9.5	0.15	2.8	0.7	0.43	0.19	F602X	F602XZZ
3	6	7.2	0.1	2	0.6	0.16	0.06	MF63	MF63ZZ
	7	8.1	0.15	2	0.5	0.24	0.10	F683	F683ZZ
	8	9.2	0.15	2.5	0.6	0.43	0.19	MF83	MF83ZZ
	8	9.5	0.15	3	0.7	0.43	0.19	F693	F693ZZ
	9	10.2	0.2	2.5	0.6	0.44	0.19	MF93	MF93ZZ
	9	10.5	0.15	3	0.7	0.44	0.19	F603	F603ZZ
	10	11.5	0.15	4	1	0.49	0.22	F623	F623ZZ
4	7	8.2	0.1	2	0.6	0.16	0.06	MF74	MF74ZZ
	8	9.2	0.15	2	0.6	0.30	0.12	MF84	MF84ZZ
	9	10.3	0.15	2.5	0.6	0.49	0.22	F684	F684ZZ
	10	11.2	0.2	3	0.6	0.45	0.19	MF104	MF104ZZ
	11	12.5	0.15	4	1	0.55	0.25	F694	F694ZZ
	12	13.5	0.2	4	1	0.74	0.35	F604	F604ZZ
	13	15	0.2	5	1	1.01	0.49	F624	F624ZZ
	16	18	0.3	5	1	1.03	0.49	F634	F634ZZ
5	8	9.2	0.1	2	0.6	0.21	0.10	MF85	MF85ZZ
	9	10.2	0.15	2.5	0.6	0.33	0.14	MF95	MF95ZZ
	10	11.2	0.15	3	0.6	0.33	0.14	MF105	MF105ZZ
	11	12.6	0.15	-	-	0.55	0.25	-	MF115ZZ
	11	12.5	0.15	3	0.8	0.55	0.25	F685	F685ZZ
	13	15	0.2	4	1	0.83	0.40	F695	F695ZZ
	14	16	0.2	5	1	1.02	0.49	F605	F605ZZ
	16	18	0.3	5	1	1.34	0.67	F625	F625ZZ
	19	22	0.3	6	1.5	1.82	0.92	F635	F635ZZ

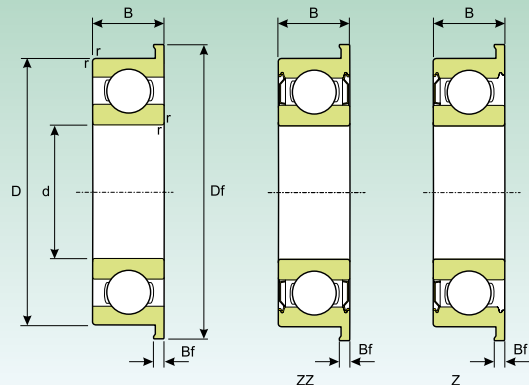
MICRORRODAMIENTOS RÍGIDOS DE BOLAS CON BRIDAS (serie métrica)
MINIATURE RADIAL BALL FLANGED BEARINGS (metric series)

Dimensión Dimension						Coeficiente de carga (KN) Load rating (KN)		Sigla Designation	
d (mm)	D (mm)	Df (mm)	r (mm)	B (mm)	Bf (mm)	Dinámico Dynamic C	Estático Static C ₀	Abierto Open	Blindado Shielded
6	10	11.2	0.15	2.5	0.6	0.38	0.18	MF106	MF106ZZ
	12	13.2	0.2	3	0.6	0.55	0.25	MF126	MF126ZZ
	13	15	0.15	3.5	1	0.83	0.40	686	F686ZZ
	15	17	0.2	5	1.2	1.03	0.49	696	F696ZZ
	17	19	0.3	6	1.2	1.53	0.75	606	F606ZZ
	19	22	0.3	6	1.5	1.82	0.92	626	F626ZZ
7	11	12.2	0.15	2.5	0.6	0.35	0.16	MF117	MF117ZZ
	13	14.2	0.2	3	0.6	0.42	0.21	MF137	MF137ZZ
	14	16	0.15	3.5	1	0.91	0.45	F687	F687ZZ
	17	19	0.3	5	1.2	1.24	0.64	F697	F697ZZ
	19	22	0.3	6	1.5	1.82	0.92	F607	F607ZZ
	22	25	0.3	7	1.5	2.56	1.38	F627	F627ZZ
8	12	13.2	0.15	2.5	0.6	0.42	0.21	MF128	MF128ZZ
	14	15.6	0.2	3.5	0.8	0.63	0.31	MF148	MF148ZZ
	16	18	0.2	4	1	0.97	0.50	F688	F688ZZ
	19	22	0.3	6	1.5	1.73	0.88	F698	F698ZZ
	22	25	0.3	7	1.5	2.56	1.38	F608	F608ZZ
9	17	19	0.2	4	1	1.03	0.55	F689	F689ZZ
	20	23	0.3	6	1.5	1.92	1.01	F699	F699ZZ
10	15	16.5	0.15	3	0.8	0.85	0.43	F6700	-
	15	16.5	0.15	4	0.8	0.85	0.43	-	F6700ZZ
	19	21	0.3	5	1	1.71	0.84	F6800	F6800ZZ
	19	21	0.3	7	1.5	1.71	0.84	F63800	F63800ZZ
	22	25	0.3	6	1.5	2.69	0.127	F6900	F6900ZZ
12	18	19.5	0.2	4	0.8	0.92	0.52	F6701	F6701ZZ
	21	23	0.3	5	1.1	1.91	1.03	F6801	F6801ZZ
	21	23	0.3	7	1.5	1.91	1.03	F63801	F63801ZZ
	24	26.5	0.3	6	1.5	2.88	1.47	F6901	F6901ZZ
15	21	22.5	0.2	4	0.8	0.94	0.58	F6702	F6702ZZ
	24	26	0.3	5	1.1	2.06	1.25	F6802	F6802ZZ
	24	26	0.3	7	1.5	2.06	1.25	F63802	F63802ZZ
	28	30.5	0.3	7	1.5	4.02	2.26	F6902	F6902ZZ
17	23	24.5	0.2	4	0.8	0.99	0.65	F6703	F6703ZZ
	26	28	0.3	5	1.1	2.23	1.46	F6803	F6803ZZ
	26	28	0.3	7	1.5	2.23	1.46	F63803	F63803ZZ
	30	32.5	0.3	7	1.5	4.58	2.56	F6903	F6903ZZ

MICRORRODAMIENTOS RÍGIDOS DE BOLAS CON BRIDAS (serie métrica)
MINIATURE RADIAL BALL FLANGED BEARINGS (metric series)

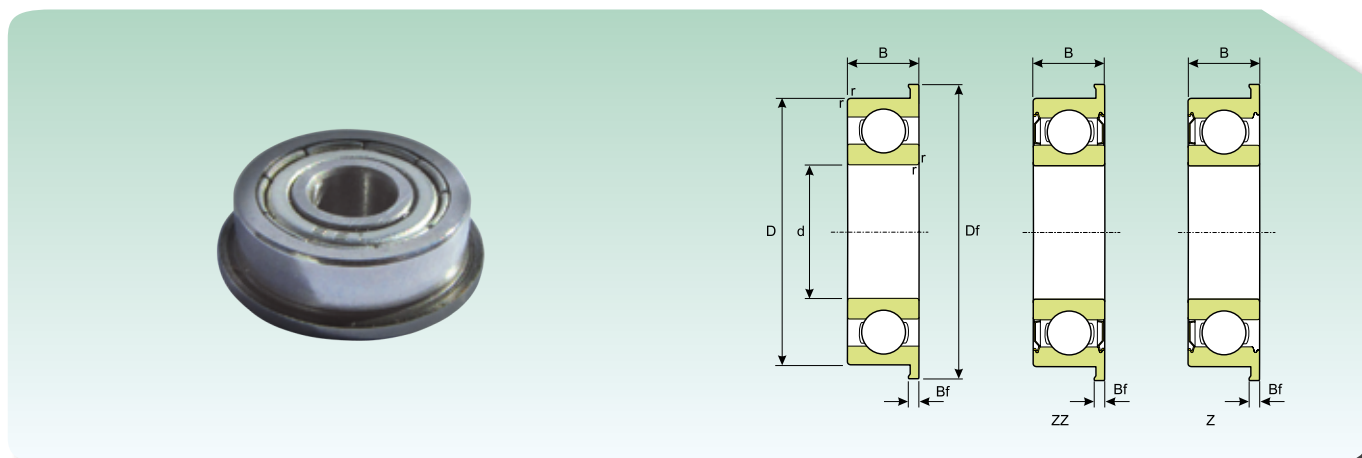

Dimensión Dimension						Coeficiente de carga (KN) Load rating (KN)		Sigla Designation	
d (mm)	D (mm)	Df (mm)	r (mm)	B (mm)	Bf (mm)	Dinámico Dynamic C	Estático Static C ₀	Abierto Open	Blindado Shielded
20	27	28.5	0.2	4	0.8	1.04	0.72	F6704	F6704ZZ
	32	35	0.3	7	1.5	4.02	2.45	F6804	F6804ZZ
	37	40	0.3	9	2	6.37	3.68	F6904	F6904ZZ
25	32	34	0.2	4	1	1.08	0.84	F6705	-
	37	40	0.3	7	1.5	4.30	2.93	F6805	F6805ZZ
	42	45	0.3	9	2	7.00	4.53	F6905	F6905ZZ
30	37	39	0.2	4	1	1.14	0.95	F6706	-
	42	45	0.3	7	1.5	4.53	3.40	F6806	F6806ZZ
	47	50	0.3	9	2	7.24	5.00	F6906	F6906ZZ

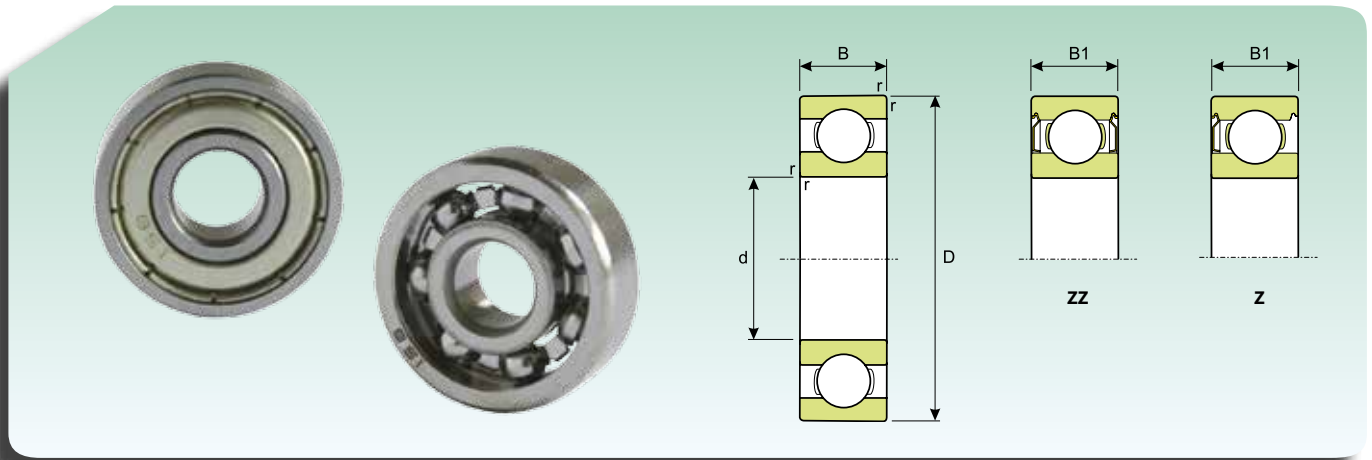
MICRODAMIENTOS RÍGIDOS DE BOLAS (serie en pulgadas)
MINIATURE RADIAL BALL BEARINGS (inch series)

Dimensión Dimension										Coeficiente de carga (KN) Load rating (KN)		Sigla Designation	
d		D		r		B		B1		Dinámico Dynamic C	Estático Static C ₀	Abierto Open	Blindado Shielded
(inch)	(mm)	(inch)	(mm)	(inch)	(mm)	(inch)	(mm)	(inch)	(mm)				
0.04	1.016	0.125	3.175	0.0039	0.1	0.0469	1.191	-	-	0.075	0.025	R09	-
0.0469	1.191	0.1562	3.967	0.0039	0.1	0.0625	1.588	0.0937	2.38	0.11	0.04	RO	ROZZ
0.055	1.397	0.1875	4.762	0.0039	0.1	0.0781	1.984	0.1094	2.779	0.18	0.075	R1	R1ZZ
0.0781	1.984	0.25	6.35	0.0039	0.1	0.0937	2.38	0.1406	3.571	0.24	0.10	R1-4	R1-4ZZ
0.0937	2.38	0.1875	4.762	0.0039	0.1	0.0625	1.588	0.0937	2.38	0.14	0.055	R133	R133ZZ
		0.3125	7.938	0.0059	0.15	0.1094	2.779	0.1406	3.571	0.43	0.19	R1-5	R1-5ZZ
0.125	3.175	0.25	6.35	0.0039	0.1	0.0937	2.38	0.1094	2.779	0.22	0.085	R144	R144ZZ
		0.3125	7.938	0.0039	0.1	0.1094	2.779	0.1406	3.571	0.43	0.19	R2-5	R2-5ZZ
		0.375	9.525	0.0059	0.15	0.1094	3.175	0.1406	3.571	0.49	0.22	R2-6	R2-6ZZ
		0.375	9.525	0.0018	0.3	0.1562	3.967	0.1562	3.967	0.49	0.22	R2	R2ZZ
0.1562	3.967	0.5	12.7	0.0018	0.3	0.1719	4.366	0.1719	4.366	0.49	0.22	R2A	R2AZZ
		0.3125	7.938	0.0039	0.1	0.1094	2.779	0.125	3.175	0.28	0.12	R155	R155ZZ
0.1875	4.762	0.3125	7.938	0.0039	0.1	0.1094	2.779	0.125	3.175	0.28	0.12	R156	R156ZZ
		0.375	9.525	0.0039	0.1	0.125	3.175	0.125	3.175	0.55	0.25	R166	R166ZZ
		0.5	12.7	0.0018	0.3	0.1562	3.967	0.196	4.978	1.01	0.49	R3	R3ZZ
0.25	6.35	0.625	15.875	0.0018	0.3	0.196	4.978	0.196	4.978	1.14	0.56	R3A	R3AZZ
		0.75	19.05	0.0157	0.4	0.2812	7.142	0.2812	7.142	1.82	0.92	R4	R4ZZ
0.3125	7.938	0.375	9.525	0.0039	0.1	0.125	3.175	0.125	3.175	0.29	0.13	R168	R168ZZ
		0.5	12.7	0.0059	0.15	0.1875	4.762	0.1875	4.762	0.83	0.40	R188	R188ZZ
0.5	12.7	0.625	15.875	0.0018	0.3	0.196	4.978	0.196	4.978	1.14	0.56	R4	R4ZZ
		0.75	19.05	0.0157	0.4	0.2812	7.142	0.2812	7.142	1.82	0.92	R4A	R4AZZ
0.3125	7.938	0.5	12.7	0.0059	0.15	0.1562	3.967	0.1562	3.967	0.42	0.21	R1810	R1810ZZ
0.375	9.525	0.875	22.225	0.0157	0.4	0.2188	5.558	0.2812	7.142	2.58	1.38	R6	R6ZZ
0.5	12.7	1.125	28.575	0.0157	0.4	0.25	6.35	0.3125	7.938	3.96	2.27	R8	R8ZZ
0.625	15.875	1.375	34.925	0.0315	0.8	0.2812	7.142	0.3437	8.731	4.65	2.84	R10	R10ZZ
0.75	19.05	1.625	41.275	0.031	0.8	0.3125	7.937	0.4375	11.1125	8.49	3.85	R12	R12ZZ

MICRORRODAMIENTOS RÍGIDOS DE BOLAS CON BRIDAS (serie en pulgadas)
MINIATURE RADIAL BALL FLANGED BEARINGS (inch series)

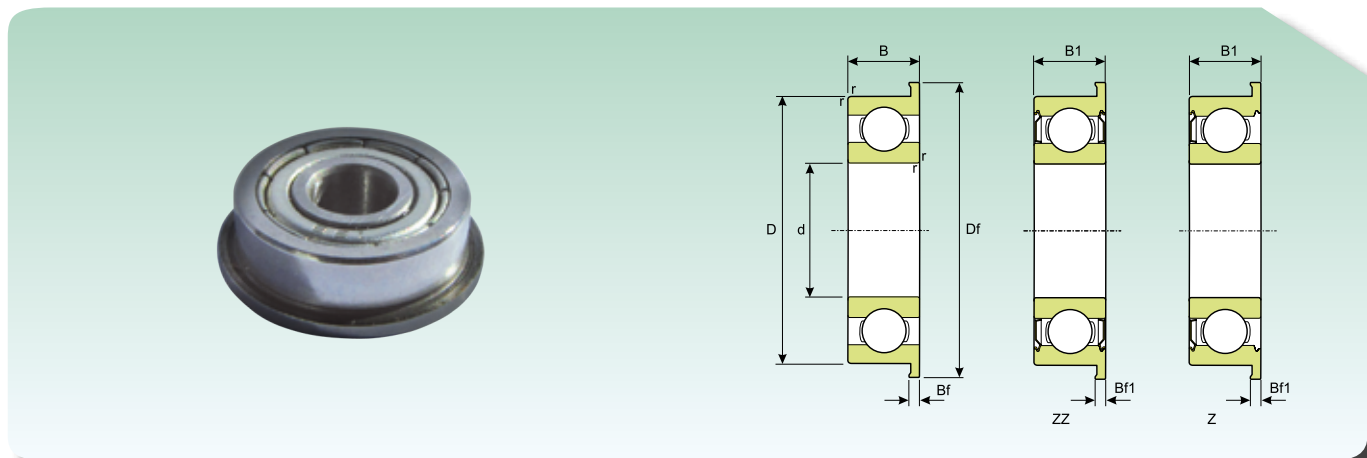

Dimensión Dimension														Coeficiente de carga Load rating			Sigla Designation			
d		D		Df		r		B		Bf		B1		Bf1		Dinámico Dynamic C (KN)	Estático Static C ₀ (KN)	Abierto Open	Blindado Shielded	
(inch)	(mm)	(inch)	(mm)	(inch)	(mm)	(inch)	(mm)	(inch)	(mm)	(inch)	(mm)	(inch)	(mm)	(inch)	(mm)					
0.0469	1.191	0.1562	3.967	0.2172	5.156	0.0039	0.1	0.0625	1.588	0.013	0.33	0.0937	2.38	0.031	0.787	0.11	0.0	4	FR0	FROZZ
0.055	1.397	0.1875	4.762	0.234	5.944	0.0039	0.1	0.0781	1.984	0.023	0.584	0.1094	2.779	0.031	0.787	0.18	0.075		FR1	FR1ZZ
0.0781	1.984	0.25	6.35	0.296	7.518	0.0039	0.1	0.0937	2.38	0.023	0.584	0.1406	3.571	0.031	0.787	0.24	0.10		FR1-4	FR1-4ZZ
0.0937	2.38	0.1875	4.762	0.234	5.944	0.0039	0.1	0.0625	1.588	0.018	0.457	0.0937	2.38	0.031	0.787	0.14	0.055		FR133	FR133ZZ
		0.3125	7.938	0.359	9.119	0.0059	0.15	0.1094	2.779	0.023	0.584	0.1406	3.571	0.031	0.787	0.43	0.19		FR1-5	FR1-5ZZ
0.125	3.175	0.25	6.35	0.296	7.518	0.0039	0.1	0.0937	2.38	0.023	0.584	0.1094	2.779	0.031	0.787	0.22	0.085		FR144	FR144ZZ
		0.3125	7.938	0.359	9.119	0.0039	0.1	0.1094	2.779	0.023	0.584	0.1406	3.571	0.031	0.787	0.43	0.19		FR2-5	FR2-5ZZ
		0.375	9.525	0.422	10.719	0.0059	0.15	0.1094	3.175	0.023	0.584	0.1406	3.571	0.031	0.787	0.49	0.22		FR2-6	FR2-6ZZ
		0.375	9.525	0.44	11.176	0.0018	0.3	0.1562	3.967	0.03	0.762	0.1562	3.967	0.03	0.762	0.49	0.22		FR2	FR2ZZ
0.1562	3.967	0.3125	7.938	0.359	9.119	0.0039	0.1	0.1094	2.779	0.023	0.584	0.125	3.175	0.036	0.914	0.28	0.12		FR155	FR155ZZ
0.1875	4.762	0.3125	7.938	0.359	9.119	0.0039	0.1	0.1094	2.779	0.023	0.584	0.125	3.175	0.036	0.914	0.28	0.12		FR156	FR156ZZ
		0.375	9.525	0.422	10.719	0.0039	0.1	0.125	3.175	0.023	0.584	0.125	3.175	0.031	0.787	0.55	0.25		FR166	FR166ZZ
		0.5	12.7	0.565	14.351	0.0018	0.3	0.1562	3.967	0.042	1.067	0.196	4.978	0.042	1.067	1.01	0.49		FR3	FR3ZZ
0.25	6.35	0.375	9.525	0.422	10.719	0.0039	0.1	0.125	3.175	0.023	0.584	0.125	3.175	0.036	0.914	0.29	0.13		FR168	FR168ZZ
		0.5	12.7	0.547	13.894	0.0059	0.15	0.1875	4.762	0.023	0.584	0.1875	4.762	0.045	1.143	0.83	0.40		FR188	FR188ZZ
		0.625	15.875	0.69	17.526	0.0018	0.3	0.196	4.978	0.042	1.067	0.196	4.978	0.042	1.067	1.14	0.56		FR4	FR4ZZ
0.3125	7.938	0.5	12.7	0.547	13.894	0.0059	0.15	0.1562	3.967	0.031	0.787	0.1562	3.967	0.031	0.787	0.42	0.21		FR1810	FR1810ZZ
0.375	9.525	0.875	22.225	0.969	24.613	0.0157	0.4	0.2188	5.558	0.062	1.575	0.2812	7.142	0.062	1.575	2.58	1.38		FR6	FR6ZZ
0.5	12.7	1.125	28.575	1.2252	31.120	0.0157	0.4	0.25	6.35	0.062	1.575	0.3125	7.938	0.062	1.575	3.96	2.27		FR8	FR8ZZ

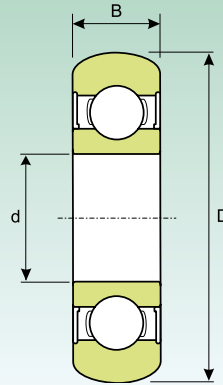
RODAMIENTOS DE BOLAS SELLADOS (aro externo bombeado-esférico)
SEALED BALL BEARINGS (outer barrel ring-spherical)

Dimensión Dimension						Coeficiente de carga (KN) Load rating (KN)		Peso (Kg) Weight (Kg)	Sigla Designation
d		D		B		Dinámico Dynamic C	Estático Static C ₀		
(inch)	(mm)	(inch)	(mm)	(inch)	(mm)				
0,3937	10	1,1811	30	0,3543	9	3750	2150	0,030	6200 2RS BOMB
0,4724	12	1,2598	32	0,3937	10	4500	2500	0,035	6201 2RS BOMB
0,5906	15	1,3780	35	0,4331	11	5650	3300	0,040	6202 2RS BOMB
0,6693	17	1,5748	40	0,4724	12	7000	4480	0,060	6203 2RS BOMB
0,7874	20	1,8504	47	0,5512	14	9880	6200	0,100	6204 2RS BOMB
0,9843	25	2,0472	52	0,5906	15	10780	6980	0,130	6205 2RS BOMB
1,1811	30	2,4409	62	0,6299	16	14970	10040	0,200	6206 2RS BOMB
1,3780	35	2,8346	72	0,6693	17	19750	13670	0,290	6207 2RS BOMB
1,5748	40	3,1496	80	0,7087	18	22710	15940	0,370	6208 2RS BOMB
1,7717	45	3,3465	85	0,7480	19	24360	17710	0,460	6209 2RS BOMB
1,9685	50	3,5433	90	0,7874	20	26980	19840	0,570	6210 2RS BOMB
2,1654	55	3,9370	100	0,8268	21	28500	21850	0,620	6211 2RS BOMB
2,3622	60	4,3307	110	0,8661	22	31700	24500	0,800	6212 2RS BOMB



Rodamientos rígidos de una hilera de bolas

Radial deep groove ball bearings, single row

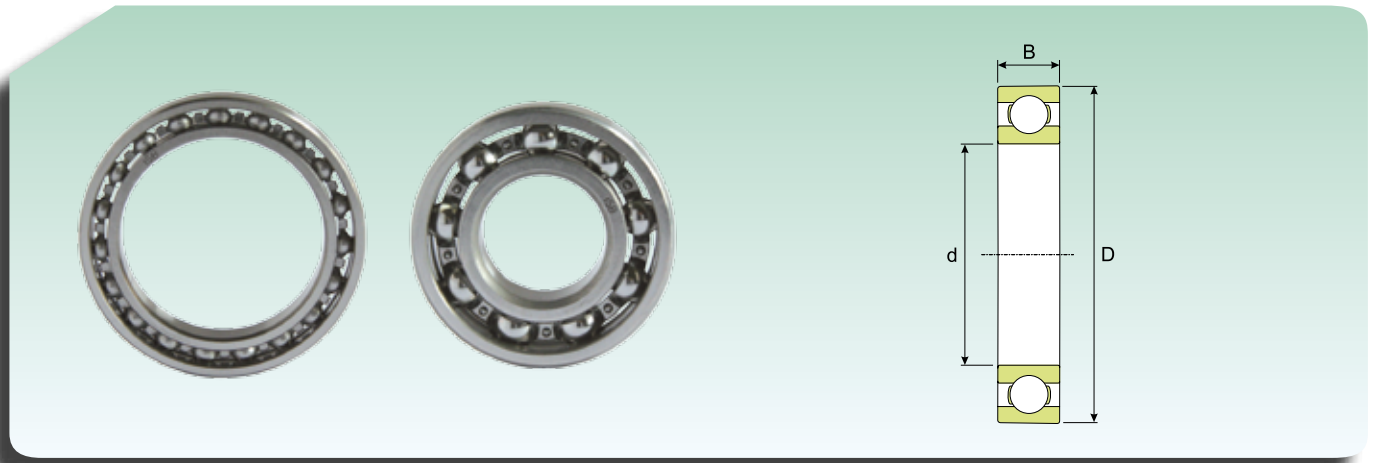

**RODAMIENTOS RÍGIDOS DE UNA HILERA DE BOLAS
RADIAL DEEP GROOVE BALL BEARINGS, SINGLE ROW**

Dimensiones (mm) Dimension (mm)			Coeficiente de carga (KN) Load rating (KN)		Velocidad límite (rpm) Speed limit (Rpm)		Peso (Kg) Weight (Kg)	Sigla Designation
d (mm)	D (mm)	B (mm)	Dinámico Dynamic C	Estático Static C ₀	Lubricación Lubrication			
					Grasa Grease	Aceite Oil		
3	10	4	0.53	0.180	61200	72000	0.0015	623
4	9	2.5	0.53	0.180	65025	76500	0.0007	618/4
	11	4	0.71	0.230	61200	72000	0.0017	619/4
	12	4	0.79	0.230	57375	67500	0.0021	604
	13	5	0.92	0.290	51255	60300	0.0031	624
5	16	5	1.1	0.380	45900	54000	0.0054	634
	11	3	0.63	0.250	57375	67500	0.0012	618/5
	13	4	0.87	0.34	51255	60300	0.0025	619/5
	16	5	1.12	0.38	45900	54000	0.0050	625
6	19	6	2.30	0.94	38250	45000	0.009	635
	13	3.5	0.87	0.34	51255	60300	0.002	618/6
	15	5	1.2	0.47	48195	56700	0.0039	619/6
7	19	6	2.30	0.94	38250	45000	0.0084	626
	14	3.5	0.94	0.4	48195	56700	0.0022	618/7
	17	5	1.45	0.55	42840	50400	0.0049	619/7
	19	6	2.30	0.94	40545	47700	0.0075	607
8	22	7	3.4	1.35	34425	40500	0.013	627
	16	4	1.3	0.56	42840	50400	0.0030	618/8
	19	6	1.9	0.73	38250	45000	0.0071	619/8
	22	7	3.4	1.35	36720	43200	0.012	608
9	24	8	3.9	1.63	30600	36000	0.017	628
	17	4	1.40	0.63	40545	47700	0.0034	618/9
	20	6	2.1	0.85	36720	43200	0.0076	619/9
	24	7	3.9	1.63	32895	38700	0.014	609
10	26	8	4.65	1.93	29070	34200	0.02	629
	15	3	66	34	36000	43000	0.005	61700
	19	5	1.40	0.58	36720	43200	0.0055	61800
	19	7	133	056	34000	40500	0.007	63800
	22	6	2.0	0.84	34425	40500	0.01	61900
	26	8	4.7	1.93	30600	36000	0.019	6000
	28	8	4.5	1.93	30600	36000	0.022	16100
30	9	5.3	2.32	26010	30600	0.032	6200	
12	35	11	8.4	3.34	24480	28800	0.053	6300
	18	4	72	41	31000	37000	0.004	61701
	21	5	1.40	0.66	32895	38700	0.0063	61801
	21	7	149	0.68	30500	36000	0.005	63801
	24	6	2.2	0.97	30600	36000	0.011	61901
	28	8	5.30	2.32	29070	34200	0.022	6001
	30	8	5	2.32	26010	30600	0.023	16101
	32	10	7.2	3.04	24480	28800	0.037	6201
37	12	9.9	4.07	21420	25200	0.06	6301	
15	21	4	81	44	27000	32000	0.006	61702
	24	5	1.53	0.79	29070	34200	0.0074	61802
	24	7	162	0.79	26000	31500	0.01	63802

RODAMIENTOS RÍGIDOS DE UNA HILERA DE BOLAS
RADIAL DEEP GROOVE BALL BEARINGS, SINGLE ROW



Dimensiones (mm) Dimension (mm)			Coeficiente de carga (KN) Load rating (KN)		Velocidad límite (rpm) Speed limit (Rpm)		Peso (Kg) Weight (Kg)	Sigla Designation
d (mm)	D (mm)	B (mm)	Dinámico Dynamic C	Estático Static C ₀	Lubrificación Lubrication			
					Grasa Grease	Aceite Oil		
15	28	7	4.28	2.2	26010	30600	0.016	61902
	32	8	5.7	2.8	24480	28800	0.025	16002
	32	9	5.7	2.8	24480	28800	0.03	6002
	35	11	7.9	3.68	21420	25200	0.045	6202
	42	13	11.7	5.3	18360	21600	0.082	6302
17	23	4	80	50	25000	30000	0.007	61703
	26	5	1.65	0.92	26010	30600	0.0082	61803
	26	7	175	0.90	24000	29500	0.013	63803
	30	7	4.53	2.5	24480	28800	0.018	61903
	35	8	6.24	3.19	21420	25200	0.032	16003
	35	10	6.24	3.19	21420	25200	0.039	6003
	40	9	9.37	4.66	18360	21600	0.048	98203
	40	12	9.8	4.66	18360	21600	0.065	6203
	47	14	14	6.42	16830	19800	0.12	6303
	62	17	22.5	10.6	13770	16200	0.27	6403
20	27	4	84	57	21000	25000	0.013	61704
	32	7	3.95	2.3	21420	25200	0.018	61804
	37	9	6.25	3.6	19890	23400	0.038	61904
	42	8	7.14	4	18360	21600	0.05	16004
	42	9	7.8	4.5	18360	21600	0.051	98204
	42	12	9.8	4.9	18360	21600	0.069	6004
	47	14	13.3	6.5	15300	18000	0.11	6204
	52	15	16.5	7.7	14535	17100	0.14	6304
	72	19	30	14.7	11475	13500	0.4	6404
22	50	14	13.8	7.5	14535	17100	0.12	62/22
	56	16	18.3	9.2	13770	16200	0.18	63/22
25	32	4	90	66	19000	23000	0.017	61705
	37	7	4.28	2.6	18360	21600	0.022	61805
	42	9	6.88	4.3	16830	19800	0.045	61905
	47	8	7.9	4.7	15300	18000	0.06	16005
	47	12	11.7	6.5	15300	18000	0.08	6005
	52	9	10.4	6.5	13770	16200	0.078	98205
	52	15	14.5	7.7	13770	16200	0.13	6205
	62	17	22.9	11.4	12240	14400	0.23	6305
	80	21	35	19	9945	11700	0.53	6405
28	58	16	16.5	9.4	12240	14400	0.18	62/28
	68	18	24.6	13.5	10710	12600	0.29	63/28
30	37	4	95	76	17000	20000	0.022	61706
	42	7	4.4	2.9	15300	18000	0.027	61806
	47	9	7.14	4.5	14535	17100	0.051	61906
	55	9	11.7	7.3	13005	15300	0.085	16006
	55	13	13.5	8.2	13005	15300	0.12	6006
	62	16	19.9	11	11475	13500	0.20	6206
	72	19	29	15.7	9945	11700	0.35	6306
	90	23	42.8	23.2	8415	9900	0.74	6406

**RODAMIENTOS RÍGIDOS DE UNA HILERA DE BOLAS
RADIAL DEEP GROOVE BALL BEARINGS, SINGLE ROW**

Dimensiones (mm) Dimension (mm)			Coeficiente de carga (KN) Load rating (KN)		Velocidad límite (rpm) Speed limit (Rpm)		Peso (Kg) Weight (Kg)	Sigla Designation
d (mm)	D (mm)	B (mm)	Dinámico Dynamic C	Estático Static C ₀	Lubrificación Lubrication			
					Grasa Grease	Aceite Oil		
35	44	5	155	130	14000	17000	0.025	61707
	47	7	4.7	3.2	13770	16200	0.03	61807
	55	10	9.37	6.7	12240	14400	0.08	61907
	62	9	12.8	8	11475	13500	0.11	16007
	62	14	16.5	10	11475	13500	0.16	6007
	72	17	26.5	15	9945	11700	0.29	6207
	80	21	34.4	18.7	9180	10800	0.46	6307
	100	25	54.2	30.4	7650	9000	0.95	6407
40	50	6	207	177	13000	16000	0.03	61708
	52	7	4.9	3.4	12240	14400	0.034	61808
	62	12	13.5	9.8	10710	12600	0.12	61908
	68	9	13.5	9	10710	12600	0.13	16008
	68	15	17.5	11.4	10710	12600	0.19	6008
	80	18	31.9	18.7	8415	9900	0.37	6208
	90	23	41.5	23.6	8415	9900	0.63	6308
	110	27	62.5	35.8	6885	8100	1.25	6408
45	55	6	213	192	12000	14000	0.035	61709
	58	7	6.5	6	10710	12600	0.04	61809
	68	12	13.8	10.6	9945	11700	0.14	61909
	75	10	16.2	10.6	9180	10800	0.17	16009
	75	16	21.7	14.4	9180	10800	0.25	6009
	85	19	34.4	21.2	8415	9900	0.41	6209
	100	25	54.2	30.9	7268	8550	0.83	6309
	120	29	74.6	44.1	6503	7650	1.55	6409
50	65	7	6.7	6.7	9945	11700	0.052	61810
	72	12	14.4	11.6	9180	10800	0.14	61910
	80	10	16.5	11.2	8415	9900	0.18	16010
	80	16	22.5	15.7	8415	9900	0.26	6010
	90	20	36.4	22.8	7650	9000	0.46	6210
	110	27	63.7	37.3	6503	7650	1.05	6310
	130	31	85.4	51	5738	6750	1.9	6410
55	72	9	8.86	8.7	9180	10800	0.083	61811
	80	13	16.2	13.8	8415	9900	0.19	61911
	90	11	19.9	13.8	7650	9000	0.26	16011
	90	18	29	20.8	7650	9000	0.39	6011
	100	21	45.3	28.5	6885	8100	0.61	6211
	120	29	72.7	44.1	6120	7200	1.35	6311
	140	33	97.6	60.8	5355	6300	2.3	6411
60	78	10	11.7	11.2	8415	9900	0.11	61812
	85	13	16.2	14.1	7650	9000	0.2	61912
	95	11	20.4	14.7	7268	8550	0.28	16012
	95	18	30.1	22.8	7268	8550	0.42	6012
	110	22	54.2	35.3	6120	7200	0.78	6212
	130	31	83.5	51	5355	6300	1.7	6312
	150	35	105.9	68.2	4820	5670	2.75	6412

RODAMIENTOS RÍGIDOS DE UNA HILERA DE BOLAS
RADIAL DEEP GROOVE BALL BEARINGS, SINGLE ROW

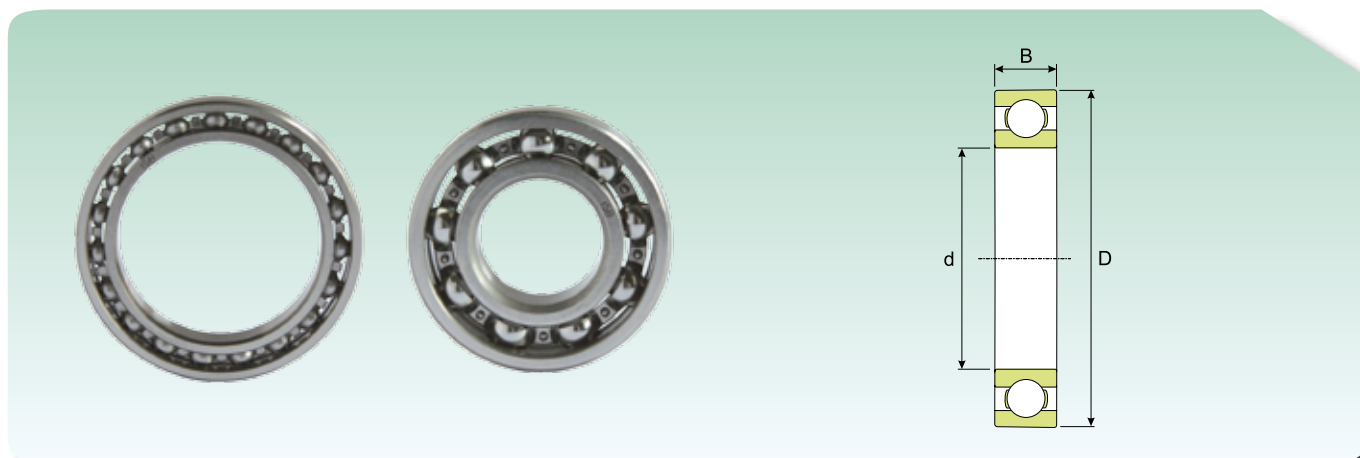

Dimensiones (mm) Dimension (mm)			Coeficiente de carga (KN) Load rating (KN)		Velocidad límite (rpm) Speed limit (Rpm)		Peso (Kg) Weight (Kg)	Sigla Designation
d (mm)	D (mm)	B (mm)	Dinámico Dynamic C	Estático Static C ₀	Lubrificación Lubrication			
					Grasa Grease	Aceite Oil		
65	85	10	12.2	12.5	7650	9000	0.13	61813
	90	13	17.1	15.7	7268	8550	0.22	61913
	100	11	22.1	16.3	6885	8100	0.3	16013
	100	18	31.3	24.5	6885	8100	0.44	6013
	120	23	57.4	39.7	5738	6750	0.99	6213
	140	33	95.6	58.8	5126	6030	2.1	6313
	160	37	116.7	76.5	4590	5400	3.30	6413
70	90	10	12.2	13	6885	8100	0.14	61814
	100	16	23.4	20.8	6503	7650	0.35	61914
	110	13	28.6	24.5	6120	7200	0.43	16014
	110	20	38.9	30.4	6120	7200	0.6	6014
	125	24	62.5	44.1	5355	6300	1.05	6214
	150	35	108.8	66.7	4820	5670	2.5	6314
	180	42	140.2	102	4055	4770	4.85	6414
75	95	10	12.5		6503	7650	0.15	61815
	105	16	23.8	19	6120	7200	0.37	61915
	110	12	28.1	26.5	6120	7200	0.38	16115
	115	13	29.6	26.5	5738	6750	0.46	16015
	115	20	40.8	32.9	5738	6750	0.64	6015
	130	25	67.7	48.3	5126	6030	1.2	6215
	160	37	116.7	75	4284	5040	3	6315
	190	45	150	111.8	3825	4500	6.8	6415
80	100	10	12.8	14.8	6120	7200	0.15	61816
	110	16	24.6	20	5738	6750	0.4	61916
	125	14	34.4	30.9	5355	6300	0.6	16016
	125	22	48.5	39.3	5355	6300	0.85	6016
	140	26	71.4	54	4590	5400	1.4	6216
	170	39	127.4	84.8	4055	4770	3.6	6316
	200	48	159.8	122.6	3672	4320	8	6416
85	110	13	19.2	20.4	5738	6750	0.27	61817
	120	18	31.3	29.5	5355	6300	0.55	61917
	130	14	35.1	32.9	5126	6030	0.63	16017
	130	22	51	42.2	5126	6030	0.89	6017
	150	28	85.4	62.8	4284	5040	1.8	6217
	180	41	137.3	94.6	3825	4500	4.25	6317
	210	52	170.6	134.3	3443	4050	9.5	6417
90	115	13	19.2	21.6	5355	6300	0.28	61818
	125	18	32.6	30.9	5126	6030	0.59	61918
	140	16	42.8	38.3	4820	5670	0.85	16018
	140	24	59.3	49.1	4820	5670	1.15	6018
	160	30	99	72.1	4055	4770	2.15	6218
	190	43	148	105.9	3672	4320	4.9	6318
	225	54	182.3	147	3290	3870	11.5	6418

**RODAMIENTOS RÍGIDOS DE UNA HILERA DE BOLAS
RADIAL DEEP GROOVE BALL BEARINGS, SINGLE ROW**

Dimensiones (mm) Dimension (mm)			Coeficiente de carga (KN) Load rating (KN)		Velocidad límite (rpm) Speed limit (Rpm)		Peso (Kg) Weight (Kg)	Sigla Designation
d (mm)	D (mm)	B (mm)	Dinámico Dynamic C	Estático Static C ₀	Lubrificación Lubrication			
					Grasa Grease	Aceite Oil		
95	120	13	19.6	22.4	5126	6030	0.3	61819
	130	18	33.2	32.9	4820	5670	0.61	61919
	145	16	43.9	40.7	4590	5400	0.89	16019
	145	24	62.5	53	4590	5400	1.2	6019
	170	32	111.8	79.9	3825	4500	2.6	6219
	200	45	155.9	115.7	3443	4050	5.65	6319
100	125	13	19.6	23.6	4820	5670	0.31	61820
	140	20	41.5	40.2	4590	5400	0.83	61920
	150	16	45.3	43.2	4284	5040	0.91	16020
	150	24	62.5	53	4284	5040	1.25	6020
	180	34	124.5	91.15	3672	4320	3.15	6220
	215	47	170.6	137.3	3290	3870	7	6320
105	130	13	20.4	19.3	4820	5670	0.32	61821
	145	20	43.4	43.2	4284	5040	0.87	61921
	160	18	53	50	4055	4770	1.2	16021
	160	26	74.6	64.2	4055	4770	1.6	6021
	190	36	137.3	102	3443	4050	3.7	6221
	225	49	178.4	150	3060	3600	8.25	6321
110	140	16	27.6	25.5	4284	5040	0.6	61822
	150	20	42.8	44.2	4284	5040	0.9	61922
	170	19	58.9	55.9	3825	4500	1.45	16022
	170	28	83.5	72.1	3825	4500	1.95	6022
	200	38	148	115.7	3290	3870	4.35	6222
	240	50	199	176.5	2907	3420	9.55	6322
120	150	16	28.6	27.6	4055	4770	0.65	61824
	165	22	54.2	55.9	3825	4500	1.2	61924
	180	19	62.5	62.9	3672	4320	1.6	16024
	180	28	86.7	78.5	3672	4320	2.05	6024
	215	40	143.1	115.7	3060	3600	5.15	6224
	260	55	203.9	182.3	2601	3060	12.5	6324
130	165	18	36.9	42.2	3672	4320	0.93	61826
	180	24	63.7	65.7	3443	4050	1.85	61926
	200	22	81.6	79.9	3290	3870	2.35	16026
	200	33	109.8	98	3290	3870	3.15	6026
	230	40	152.9	129.4	2754	3240	5.8	6226
	280	58	224.5	211.7	3443	4050	17.5	6326 M
140	175	18	38.3	45.6	3443	4050	0.99	61828
	190	24	65	70.6	4284	5040	1.7	61928 MA
	210	22	79	84.8	3060	3600	2.5	16028
	210	33	108.8	105.9	3060	3600	3.35	6028
	250	42	161.8	147	2601	3060	7.45	6228
	300	62	246	240.2	3290	3870	22	6328 M

RODAMIENTOS RÍGIDOS DE UNA HILERA DE BOLAS RADIAL DEEP GROOVE BALL BEARINGS, SINGLE ROW

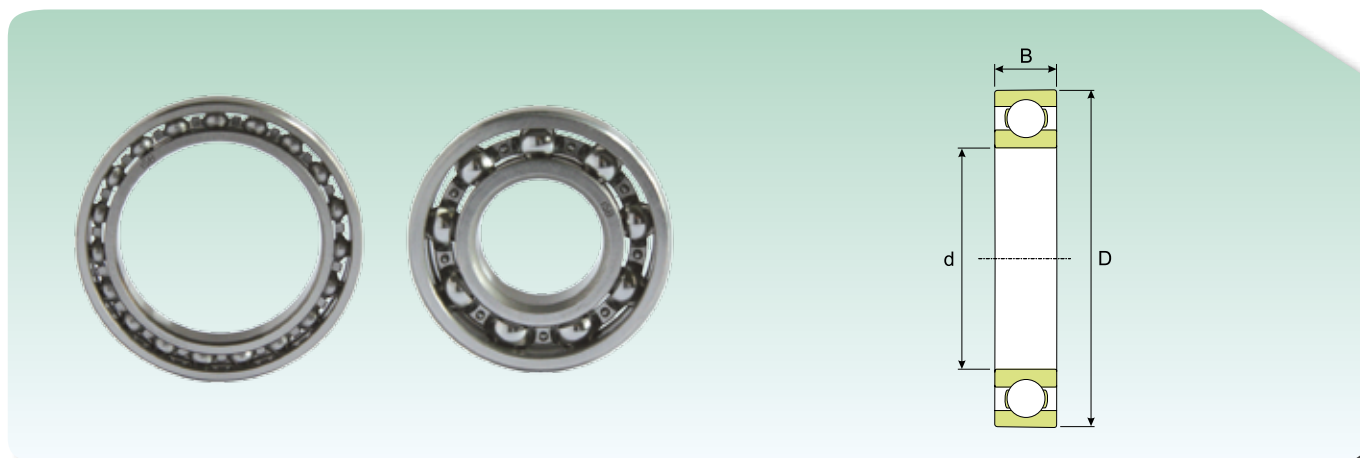

Dimensiones (mm) Dimension (mm)			Coeficiente de carga (kN) Load rating (kN)		Velocidad límite (rpm) Speed limit (Rpm)		Peso (Kg) Weight (Kg)	Sigla Designation
d (mm)	D (mm)	B (mm)	Dinámico Dynamic C	Estático Static C ₀	Lubricación Lubrication			
					Grasa Grease	Aceite Oil		
150	190	20	47.9	59.8	3290	3870	1.4	61830
	210	28	86.7	91.2	4055	4770	3.05	61930 MA
	225	24	90.4	96.1	2907	3420	3.15	16030
	225	35	122.6	122.6	2907	3420	4.8	6030
	270	45	170.6	162.7	2448	2880	9.4	6230
	320	65	270.5	279.4	3060	3600	26	6330 M
160	200	20	48.5	62.8	3060	3600	1.4	61832
	220	28	90.5	96.1	3825	4500	3.2	61932 MA
	240	25	97.6	105.9	2754	3240	3.7	16032
	240	38	140.2	140.2	2754	3240	5.9	6032
	240	38	140.2	140.2	3672	4320	5.9	6032 M
	290	48	182.3	182.3	2295	2700	14	6232
	340	68	270.5	279.3	2907	3420	29	6332 M
170	215	22	60.6	76.5	2754	3240	1.9	61834
	230	28	91.8	103.9	3672	4320	3.4	61934 MA
	260	28	116.7	126.5	2448	2880	5	16034
	260	42	164.7	169.6	3290	3870	7.9	6034 M
	310	52	207.8	219.7	2907	3420	17.5	6234 M
	360	72	305.8	334	2601	3060	34.5	6334 M
180	225	22	61.2	80	2601	3060	2	61836
	250	33	116.7	131.2	3290	3870	5.05	61936 MA
	280	31	135.3	143	3060	3600	6.6	16036
	280	46	186.3	197	3060	3600	10.5	6036 M
	320	52	224.5	236	2754	3240	18.5	6236 M
	380	75	344	397	2448	2880	42.5	6336 M
190	240	24	74.6	96	2448	2880	2.6	61838
	260	33	114.7	133	3290	3870	5.25	61938 MA
	290	31	145.1	163	2295	2700	7.9	16038
	290	46	191.2	212	2907	3420	11	6038 M
	340	55	245	275	2601	3060	23	6238 M
	400	78	363.6	422	2295	2700	49	6338 M
200	250	24	74.6	100	2448	2880	2.7	61840
	280	38	145.1	163	2907	3420	7.4	61940 MA
	310	34	164.7	186	2142	2520	8.85	16040
	310	51	211.7	240	2754	3240	14	6040 M
	360	58	264.7	304	2448	2880	28	6240 M
220	270	24	76.5	108	2142	2520	3	61844
	300	38	148	177	2754	3240	8	61944 MA
	340	37	170.6	200	1836	2160	11.5	16044
	340	56	242.1	285	2448	2880	18.5	6044 M
	400	65	290.1	358	2295	2700	37	6244 M
	460	88	401.9	510	1989	2340	72.5	6344 M
240	300	28	105.9	147	1989	2340	4.5	61848
	320	38	155.9	196	2448	2880	8.6	61948 MA
	360	37	174.5	216	2295	2700	14.5	16048 MA

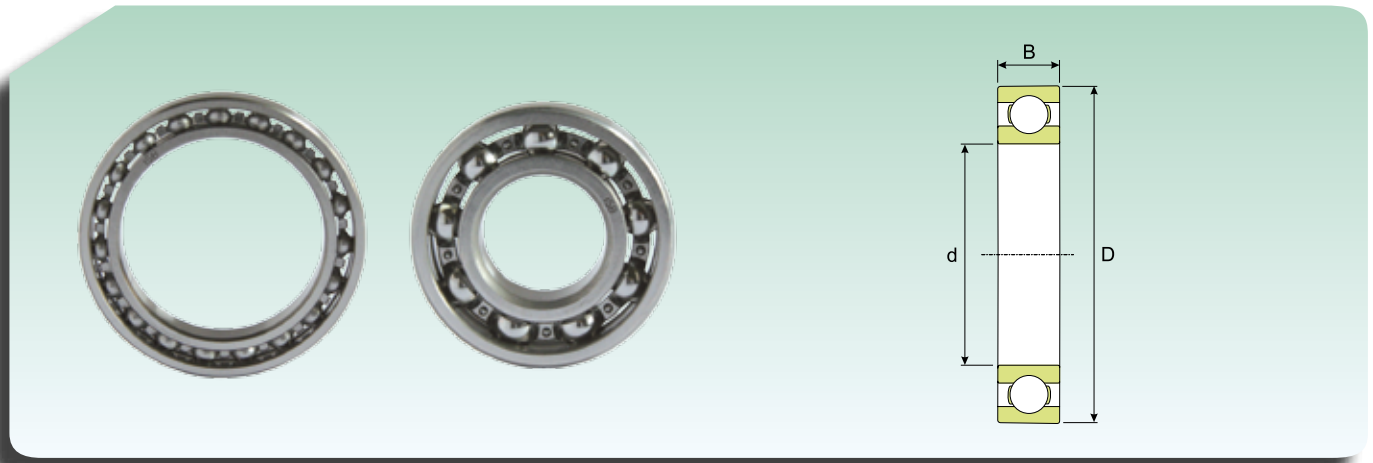
**RODAMIENTOS RÍGIDOS DE UNA HILERA DE BOLAS
RADIAL DEEP GROOVE BALL BEARINGS, SINGLE ROW**

Dimensiones (mm) Dimension (mm)			Coeficiente de carga (KN) Load rating (KN)		Velocidad límite (rpm) Speed limit (Rpm)		Peso (Kg) Weight (Kg)	Sigla Designation
d (mm)	D (mm)	B (mm)	Dinámico Dynamic C	Estático Static C ₀	Lubricación Lubrication			
					Grasa Grease	Aceite Oil		
240	360	56	250	309	2295	2700	19	6048 M
	440	72	350.9	456	1989	2340	51	6248 M
	500	95	433.2	574	1836	2160	92.5	6348 M
260	320	28	108.8	160	1836	2160	4.8	61852
	360	46	207.8	265	2295	2700	14.5	61952 MA
	400	44	233.3	304	2142	2520	21.5	16052 MA
	400	65	285.2	368	2142	2520	29.5	6052 M
	480	80	382.3	520	1836	2160	65	6252 M
540	102	496.9	696	1683	1980	115	6352 M	
280	350	33	135.3	197	1683	1980	7.4	61856
	380	46	211.7	279	2142	2520	15	61956 MA
	420	44	237.2	329	1989	2340	23	16056 MA
	420	65	296	397	1989	2340	31	6056 M
	500	80	414.6	588	1683	1980	71	6256 M
300	380	38	168.6	241	1989	2340	10.5	61860 MA
	420	56	264.7	368	1836	2160	24.5	61960 MA
	460	50	280.3	397	1836	2160	32	16060 MA
	460	74	350.9	491	1836	2160	44	6060 M
	540	85	452.8	657	1530	1800	88.5	6260 M
320	400	38	168.6	250	1836	2160	11	61864 MA
	440	56	270.5	393	1836	2160	25.5	61964 MA
	480	50	275.4	397	1683	1980	34	16064 MA
	480	74	363.6	530	1683	1980	46	6064 M
340	420	38	174.5	270	1836	2160	11.5	61868MA
	460	56	275.4	417	1683	1980	26.5	61968MA
	520	57	338.2	510	1530	1800	45	16068MA
	520	82	414.6	628	1530	1800	62	6068M
360	440	38	178.4	280	1683	1980	12	61872 MA
	480	56	285.2	442	1683	1980	28	61972 MA
	540	57	344	539	1454	1710	49	16072 MA
	540	82	452.8	721	1454	1710	64.5	6072 M
380	480	46	237.2	382	1530	1800	20	61876 MA
	520	65	331.3	530	1454	1710	40	61976 MA
	560	57	369.5	608	1377	1620	51	16076 MA
	560	82	452.8	735	1377	1620	67.5	6076 M
400	500	46	242.1	397	1454	1710	20.5	61880 MA
	540	65	338.2	559	1377	1620	41.5	61980 MA
	600	90	509.7	848	1301	1530	87.5	6080 M
420	520	46	246	417	1377	1620	21.5	61884 MA
	560	65	344	589	1377	1620	43	61984 MA
	620	90	496.9	863	1224	1440	91.5	6084 M

RODAMIENTOS RÍGIDOS DE UNA HILERA DE BOLAS
RADIAL DEEP GROOVE BALL BEARINGS, SINGLE ROW

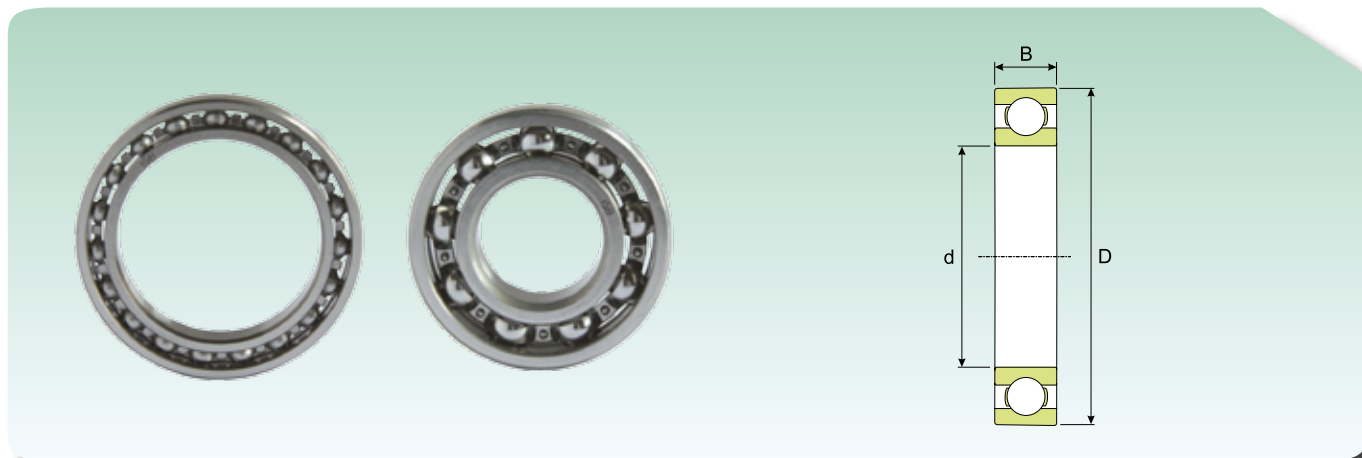

Dimensiones (mm) Dimension (mm)			Coeficiente de carga (KN) Load rating (KN)		Velocidad límite (rpm) Speed limit (Rpm)		Peso (Kg) Weight (Kg)	Sigla Designation
d (mm)	D (mm)	B (mm)	Dinámico Dynamic C	Estático Static C ₀	Lubrificación Lubrication			
					Grasa Grease	Aceite Oil		
440	540	31	155	285	870	1000	16.5	60888
	540	46	250	432	1377	1620	22.5	61888 MA
	600	50	305	550	870	1000	41	60988
	600	74	401.9	706	1224	1440	60.5	61988 MA
	650	94	542	946	1148	1350	105	6088 M
460	580	56	312.7	559	1224	1440	35	61892 MA
	620	72	410	765	870	1100	63	61992
	620	74	414.6	735	1224	1440	62.5	61992 MA
	680	100	570.4	1039	1148	1350	120	6092 MB
480	600	56	318.6	588	1224	1440	36.5	61896 MA
	650	78	440.1	799	1148	1350	74	61996 MA
	700	100	605.7	1117	1071	1260	125	6096 MB
500	620	37	220	445	800	950	20	608/500
	620	56	325.4	608	1148	1350	40.5	618/500 MA
	660	75	440	720	750	900	68.8	619/500X3F1
	670	78	452.8	848	1071	1260	77	619/500 MA
	720	100	593	1117	995	1170	135	60/500 N1MAS
530	650	56	325.4	645	1071	1260	39.5	618/530 MA
	710	57	410	810	690	840	60	609/530
	710	82	478.3	912	995	1170	90.5	619/530 MA
	780	112	637	1245	918	1080	185	60/530 N1MAS
560	680	37	220	460	710	860	30	608/560
	680	56	338.2	682	995	1170	42	618/560 MA
	750	85	484.2	961	918	1080	105	619/560 MA
	820	115	649.8	1441	918	1080	210	60/560 N1MAS
600	730	42	260	550	670	800	41	608/600
	730	60	356.8	750	918	1080	52	618/600 MA
	800	90	573.4	1197	842	990	125	619/600 MA
	870	118	692	1450	600	700	233	60/600/HC
630	780	48	355	765	640	760	41	608/630
	780	69	433.2	946	842	990	73	618/630 MA
	850	71	475	1050	600	710	112	609/630
	850	100	611.6	1314	842	990	160	619/630 N1MA
	920	128	802.7	1725	765	900	285	60/630 N1MAS
670	820	69	433.2	980	842	990	83.5	618/670 MA
	900	103	662.5	1470	765	900	185	619/670 MA
	980	136	886	1999	689	810	345	60/670 N1MAS
710	870	74	465.6	1078	765	900	93.5	618/710 MA
	950	78	545	1280	500	610	148	609/710
	950	106	649.8	1470	689	810	220	619/710 MA
	1030	140	936.9	2157	650	765	375	60/710 MA
750	920	78	516.5	1226	689	810	110	618/750 MA
	1000	112	745.8	1765	650	765	255	619/750 MA
	1090	150	975	2370	450	530	490	60/750

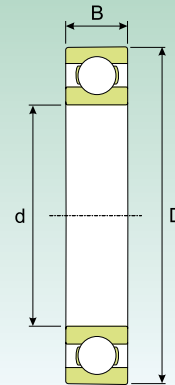
**RODAMIENTOS RÍGIDOS DE UNA HILERA DE BOLAS
RADIAL DEEP GROOVE BALL BEARINGS, SINGLE ROW**

Dimensiones (mm) Dimension (mm)			Coeficiente de carga (KN) Load rating (KN)		Velocidad límite (rpm) Speed limit (Rpm)		Peso (Kg) Weight (Kg)	Sigla Designation
d (mm)	D (mm)	B (mm)	Dinámico Dynamic C	Estático Static C ₀	Lubrificación Lubrication			
					Grasa Grease	Aceite Oil		
800	980	57	390	990	430	510	100	608/800
	980	82	547.9	1343	650	765	130	618/800 MA
	1060	115	815.4	2000	612	720	275	619/800 MA
	1150	155	989.9	2500	574	675	535	60/800 N1MAS
850	1030	57	385	1000	450	500	75	608/850
	1030	82	547.9	1402	574	675	140	618/850 MA
	1120	118	815	2150	400	480	315	619/850
	1220	165	1090	2980	370	430	640	60/850
900	1090	85	605.7	1567	536	630	160	618/900 MA
	1180	122	830	2270	360	440	355	619/900
	1280	170	1080	3120	330	410	725	60/900
950	1150	90	663	1620	360	430	188	618/950F1
	1250	132	985	2850	330	410	395	619/950
	1360	180	1145	3315	310	380	850	60/950
1000	1220	71	540	1550	350	400	175	608/1000
	1220	100	624.3	1765	459	540	245	618/1000 MA
	1320	103	800	2340	330	380	405	609/1000
	1320	140	985	2880	330	380	525	619/1000
	1420	185	1320	3900	280	340	925	60/1000
1060	1280	100	713.5	2077.7	428	504	260	618/1060 MA
	1400	150	985	3030	290	330	615	619/1060
	1500	195	1320	3860	250	330	1090	60/1060
1120	1360	106	726.2	2157	405	477	315	618/1120 MA
	1460	150	1010	3070	270	330	640	619/1120
	1580	200	1430	4480	250	300	1245	60/1120
1180	1420	106	745.8	2312.9	367	432	330	618/1180 MB
	1540	160	1115	3630	210	270	765	619/1180
1250	1500	112	830	2740	210	270	390	618/1250
1280	1560	150	939	2750	220	280	606	66/1280F1
	1600	122	955	2830	200	260	512	618/1320F3
1320	1720	128	1180	4060	190	230	835	609/1320
	1400	1700	132	1070	3980	190	230	620
1400	1820	185	1550	5520	180	230	1260	619/1400
	1500	1820	140	1685.7	5980	245	288	690
1950		195	1680	6220	160	190	1515	619/1500
1600	1950	155	1240	4750	150	180	975	618/1600
	2060	200	1820	6880	140	170	1660	619/1600
1700	2060	160	1240	4950	130	160	1110	618/1700
	2180	212	1950	7680	120	150	1930	619/1700

RODAMIENTOS RÍGIDOS DE UNA HILERA DE BOLAS, BLINDADOS
SEALED RADIAL DEEP GROOVE BALL BEARINGS

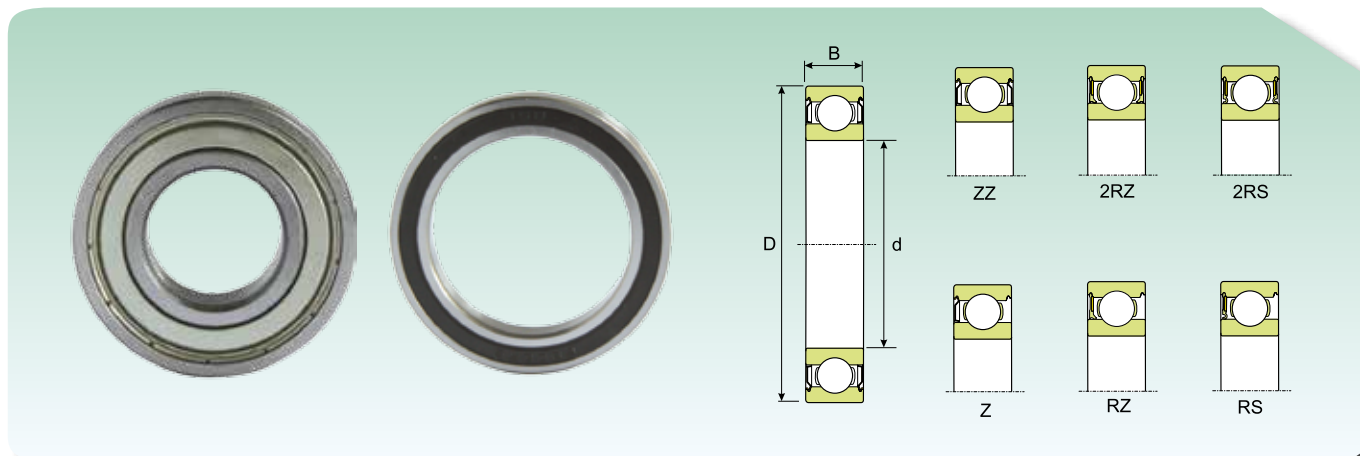

Dimensiones (mm) Dimension (mm)			Coeficiente de carga (KN) Load rating (KN)		Velocidad límite* Speed limit*	Peso (Kg) Weight (Kg)	Sigla Designation	
d (mm)	D (mm)	B (mm)	Dinámico Dynamic C	Estático Static C ₀			Blindaje de un lado One side shield	Blindaje en ambos lados Two side shield
3	10	4	0.53	0.18	57000	0.0015	623-Z	623-ZZ
	10	4	0.53	0.18	38000	0.0015	623-RS	623-2RS
4	9	3.5	0.53	0.18	66500	0.001	-	628/4-ZZ
	9	4	0.53	0.18	66500	0.0013	-	638/4-ZZ
	11	4	0.71	0.23	59850	0.0017	-	619/4-ZZ
	12	4	0.79	0.28	57000	0.0021	604-Z	604-ZZ
	13	5	0.92	0.29	50350	0.0031	624-Z	624-ZZ
	13	5	0.92	0.29	50350	0.0031	624-RS	624-2RS
	16	5	1.09	0.38	45600	0.0054	634-Z	634-ZZ
	16	5	1.09	0.38	45600	0.0054	634-RZ	634-2RZ
5	16	5	1.09	0.38	26600	0.0054	634-RS	634-2RS
	11	4	0.63	0.25	57000	0.0014	-	628/5-ZZ
	11	5	0.63	0.25	57000	0.0016	-	638/5-ZZ
	13	4	0.87	0.34	50350	0.0025	-	619/5-ZZ
	16	5	1.12	0.38	45600	0.005	625-Z	625-ZZ
	16	5	1.12	0.38	45600	0.005	625-RS	625-2RS
	19	6	2.3	0.94	38000	0.009	635-Z	635-ZZ
	19	6	2.3	0.94	38000	0.009	635-RZ	635-2RZ
6	19	6	2.3	0.94	22800	0.009	635-RS	635-2RS
	13	5	0.87	0.34	50350	0.0026	-	628/6-ZZ
	15	5	1.22	0.47	47500	0.0039	-	619/6-ZZ
	19	6	2.3	0.94	38000	0.0084	626-Z	626-ZZ
7	19	6	2.3	0.94	22800	0.0084	626-RS	626-2RS
	14	5	0.94	0.4	47500	0.0031	-	628/7-ZZ
	17	5	1.46	0.55	42750	0.0049	-	619/7-ZZ
	19	6	2.3	0.94	40850	0.0075	607-Z	607-ZZ
	19	6	2.3	0.94	22800	0.0075	607-RS	607-2RS
	22	7	3.39	1.35	34200	0.013	627-Z	627-ZZ
	22	7	3.39	1.35	20900	0.012	627-RS	627-2RS
8	16	5	1.31	0.56	42750	0.0036	-	628/8-ZZ
	16	5	1.31	0.56	24700	0.0036	-	628/8-2RS
	16	6	1.31	0.56	42750	0.0043	-	638/8-ZZ
	19	6	1.87	0.73	38000	0.0071	-	619/8-ZZ
	19	6	1.87	0.73	22800	0.0071	-	619/8-2RS
	22	7	3.39	1.35	36100	0.012	608-Z	608-ZZ
	22	7	3.39	1.35	20900	0.012	608-RS	608-2RS
	22	11	3.39	1.35	20900	0.016	-	630/8-2RS
	24	8	3.83	1.63	30400	0.017	628-Z	628-ZZ
	24	8	3.83	1.63	30400	0.017	628-RS	628-2RS
	24	8	3.83	1.63	18050	0.017	628-RZ	628-2RZ
	28	9	4.53	1.93	28500	0.03	638-RZ	638-2RZ
9	17	5	1.41	0.63	40850	0.0043	628/9-Z	628/9-ZZ
	17	5	1.41	0.63	22800	0.0043	-	628/9-2RS
	20	6	2.04	0.85	36100	0.0076	-	619/9-ZZ

* Para los rodamientos blindados sólo de un lado son válidas las velocidades límite de los rodamientos abiertos
 * For one side shield bearings speed limit, use the same value of open bearings

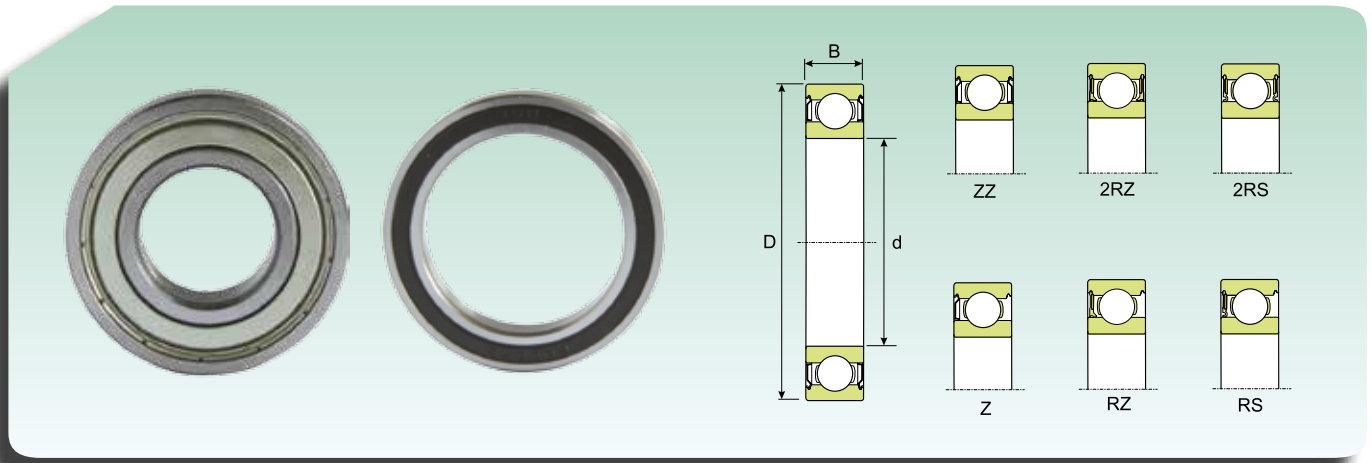
**RODAMIENTOS RÍGIDOS DE UNA HILERA DE BOLAS, BLINDADOS
SEALED RADIAL DEEP GROOVE BALL BEARINGS**

Dimensiones (mm) Dimension (mm)			Coeficiente de carga (KN) Load rating (KN)		Velocidad límite* Speed limit*	Peso (Kg) Weight (Kg)	Sigla Designation	
d (mm)	D (mm)	B (mm)	Dinámico Dynamic C	Estático Static C ₀			Blindaje de un lado One side shield	Blindaje en ambos lados Two side shield
9	24	7	3.83	1.63	32300	0.014	609-Z	609-ZZ
	24	7	3.83	1.63	18050	0.014	609-RS	609-2RS
	26	8	4.66	1.93	28500	0.02	629-Z	629-ZZ
	26	8	4.66	1.93	18050	0.02	629-RS	629-2RS
10	15	4	66	34	36000	0.0055	-	61700ZZ
	19	5	1.36	0.58	36100	0.0055	-	61800-ZZ
	19	5	1.36	0.58	20900	0.0055	-	61800-2RS
	19	7	133	0.56	34000	0.0055	-	63800ZZ
	22	6	2.04	0.84	34200	0.01	-	61900-ZZ
	22	6	2.04	0.84	19000	0.01	-	61900-2RS
	26	8	4.66	1.93	32300	0.019	6000-Z	6000-ZZ
	26	8	4.66	1.93	18050	0.019	6000-RS	6000-2RS
	26	12	4.53	1.93	18050	0.025	-	63000-2RS
	28	8	4.53	1.93	30400	0.022	-	16100-ZZ
	30	9	5.3	2.32	26600	0.032	6200-Z	6200-ZZ
	30	9	5.3	2.32	16150	0.032	6200-RS	6200-2RS
	30	14	4.97	2.32	16150	0.04	-	62200-2RS
	35	11	8.35	3.34	24700	0.053	6300-Z	6300-ZZ
	35	11	8.35	3.34	14250	0.053	6300-RS	6300-2RS
	35	17	7.9	3.34	14250	0.06	-	62300-2RS
12	18	4	72	41	31000	0.0063	-	61701-ZZ
	21	5	1.41	0.66	34200	0.0063	-	61801-ZZ
	21	5	1.41	0.66	19000	0.0063	-	61801-2RS
	21	7	149	0.68	30500	0.0063	-	63801-ZZ
	24	6	2.21	0.97	30400	0.011	-	61901-ZZ
	24	6	2.21	0.97	18050	0.011	-	61901-2RS
	28	8	5.3	2.32	28500	0.022	6001-Z	6001-ZZ
	28	8	5.3	2.32	16150	0.022	6001-RS	6001-2RS
	28	12	4.97	2.32	16150	0.029	-	63001-2RS
	30	8	4.97	2.32	26600	0.023	-	16101-ZZ
	30	8	4.97	2.32	15200	0.023	-	16101-2RS
	32	10	7.14	3.04	24700	0.037	6201-Z	6201-ZZ
	32	10	7.14	3.04	14250	0.037	6201-RS	6201-2RS
	32	14	6.76	3.04	14250	0.045	-	62201-2RS
	37	12	9.9	4.07	20900	0.06	6301-Z	6301-ZZ
	37	12	9.9	4.07	13300	0.06	6301-RS	6301-2RS
	37	17	9.56	4.07	13300	0.07	-	62301-2RS
15	21	4	81	44	27000	0.0074	-	61702-ZZ
	24	5	1.53	0.79	28500	0.0074	-	61802-ZZ
	24	5	1.53	0.79	16150	0.0074	-	61802-2RS
	24	7	162	0.79	26000	0.016	-	613802-ZZ
	28	7	4.28	2.2	26600	0.016	-	61902-ZZ
	28	7	4.28	2.2	26600	0.016	-	61902-2RZ
	28	7	4.28	2.2	15200	0.016	-	61902-2RS
	32	8	5.74	2.8	24700	0.025	16002-Z	16002-ZZ
	32	9	5.74	2.8	24700	0.03	6002-Z	6002-ZZ
	32	9	5.74	2.8	13300	0.03	6002-RS	6002-2RS

* Para los rodamientos blindados sólo de un lado son válidas las velocidades límite de los rodamientos abiertos
* For one side shield bearings speed limit, use the same value of open bearings

RODAMIENTOS RÍGIDOS DE UNA HILERA DE BOLAS, BLINDADOS
SEALED RADIAL DEEP GROOVE BALL BEARINGS

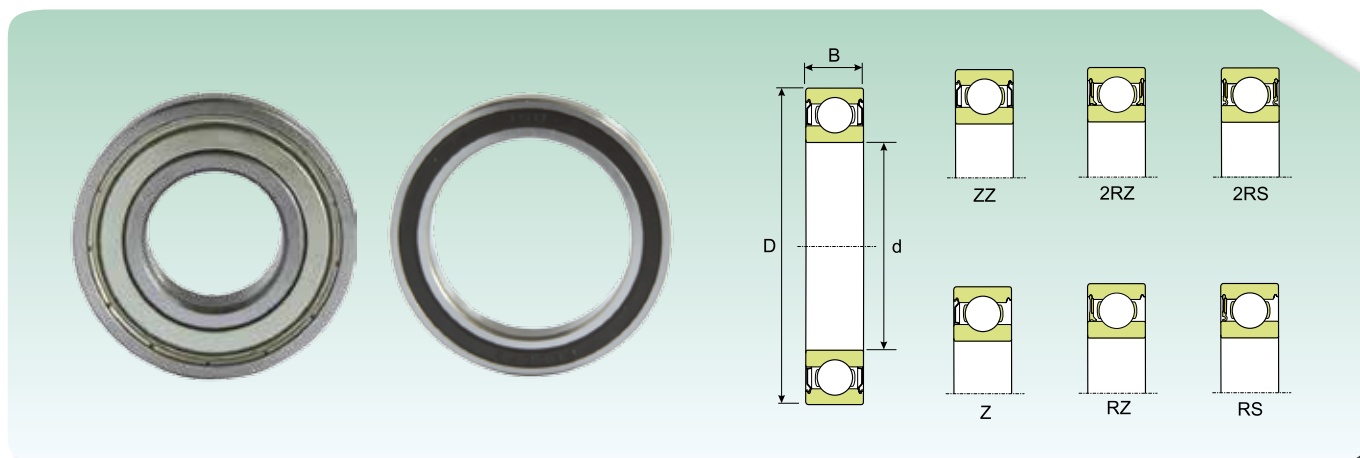

Dimensiones (mm) Dimension (mm)			Coeficiente de carga (KN) Load rating (KN)		Velocidad límite* Speed limit*	Peso (Kg) Weight (Kg)	Sigla Designation	
d (mm)	D (mm)	B (mm)	Dinámico Dynamic C	Estático Static C ₀			Blindaje de un lado One side shield	Blindaje en ambos lados Two side shield
15	32	13	5.48	2.8	13300	0.039	-	63002-2RS
	35	11	7.9	3.68	20900	0.045	6202-Z	6202-ZZ
	35	11	7.9	3.68	12350	0.045	6202-RS	6202-2RS
	35	14	7.65	3.68	12350	0.054	-	62202-2RS
	42	13	11.67	5.3	18050	0.082	6302-Z	6302-ZZ
	42	13	11.67	5.3	11400	0.082	6302-RS	6302-2RS
	42	17	11.18	5.3	11400	0.11	-	62302-2RS
17	23	4	80	50	25000	0.0082	-	61703-ZZ
	26	5	1.65	0.92	26600	0.0082	-	61803-ZZ
	26	5	1.65	0.92	26600	0.0082	-	61803-2RZ
	26	5	1.65	0.92	15200	0.0082	-	61803-2RS
	26	7	1.75	0.90	24000	0.0082	-	63803-ZZ
	30	7	4.53	2.5	24700	0.018	-	61903-ZZ
	30	7	4.53	2.5	24700	0.018	-	61903-RZ
	30	7	4.53	2.5	13300	0.018	-	61903-2RS
	35	8	6.25	3.19	20900	0.032	-	16003-ZZ
	35	10	6.25	3.19	20900	0.039	6003-Z	6003-ZZ
	35	10	6.25	3.19	12350	0.039	6003-RS	6003-2RS
	35	14	5.93	3.19	12350	0.052	-	63003-2RS
	40	12	9.76	4.66	18050	0.065	6203-Z	6203-ZZ
	40	12	9.76	4.66	11400	0.065	6203-RS	6203-2RS
	40	16	9.37	4.66	11400	0.083	-	62203-2RS
	47	14	14.02	6.42	16150	0.12	6303-Z	6303-ZZ
	47	14	14.02	6.42	10450	0.12	6303-RS	6303-2RS
47	19	13.23	6.42	10450	0.15	-	62303-2RS	
20	27	4	84	57	21000	0.018	-	61704-ZZ
	32	7	3.95	2.28	20900	0.018	-	61804-2RZ
	32	7	3.95	2.28	12350	0.018	-	61804-2RS
	37	9	6.25	3.58	19000	0.038	-	61904-2RZ
	37	9	6.25	3.58	11400	0.038	-	61904-2RS
	42	12	9.76	4.9	18050	0.069	6004-Z	6004-ZZ
	42	12	9.76	4.9	10450	0.069	6004-RS	6004-2RS
	42	16	9.18	4.9	10450	0.086	-	63004-2RS
	47	14	13.23	6.42	16150	0.11	6204-Z	6204-ZZ
	47	14	13.23	6.42	9500	0.11	6204-RS	6204-2RS
	47	18	12.45	6.42	9500	0.13	-	62204-2RS
	52	15	16.47	7.65	14250	0.14	6304-Z	6304-ZZ
	52	15	16.47	7.65	9025	0.14	6304-RS	6304-2RS
	52	21	15.59	7.65	9025	0.2	-	62304-2RS
22	50	14	13.72	7.5	8550	0.12	-	62/22-2RS
25	32	4	90	66	19000	23000	-	61705ZZ
	37	7	4.28	2.55	18050	0.022	-	61805-2RZ
	37	7	4.28	2.55	10450	0.022	-	61805-2RS
	42	9	6.88	4.22	17100	0.045	-	61905-2RZ
	42	9	6.88	4.22	9500	0.045	-	61905-2RS
	47	12	11.67	6.42	15200	0.08	6005-Z	6005-ZZ

* Para los rodamientos blindados sólo de un lado son válidas las velocidades límite de los rodamientos abiertos
 * For one side shield bearings speed limit, use the same value of open bearings

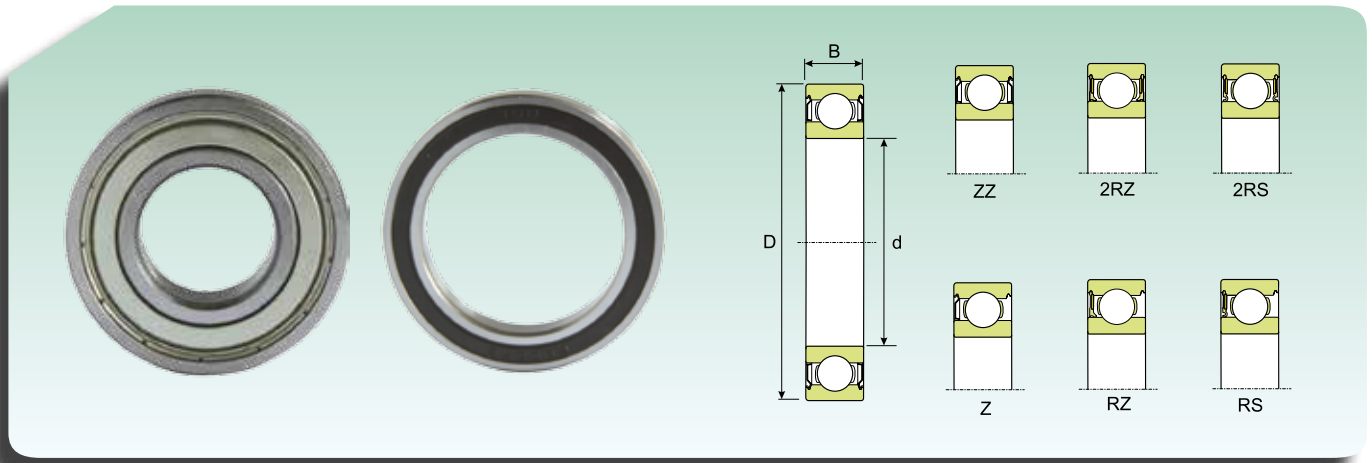
**RODAMIENTOS RÍGIDOS DE UNA HILERA DE BOLAS, BLINDADOS
SEALED RADIAL DEEP GROOVE BALL BEARINGS**

Dimensiones (mm) Dimension (mm)			Coeficiente de carga (KN) Load rating (KN)		Velocidad límite* Speed limit*	Peso (Kg) Weight (Kg)	Sigla Designation		
d (mm)	D (mm)	B (mm)	Dinámico Dynamic C	Estático Static C ₀			Blindaje de un lado One side shield	Blindaje en ambos lados Two side shield	
25	47	12	11.67	6.42	9025	0.08	6005-RS	6005-2RS	
	47	16	10.98	6.42	9025	0.1	-	63005-2RS	
	52	15	14.51	7.65	13300	0.13	6205-Z	6205-ZZ	
	52	15	14.51	7.65	8075	0.13	6205-RS	6205-2RS	
	52	18	13.72	7.65	8075	0.15	-	62205-2RS	
	62	17	22.94	11.37	12350	0.23	6305-Z	6305-ZZ	
	62	17	22.94	11.37	12350	0.23	6035-RZ	6305-2RZ	
	62	17	22.94	11.37	7125	0.23	6035-RS	6305-2RS	
	62	24	22.05	11.37	7125	0.32	-	62305-2RS	
30	37	4	95	76	17000	0.027	-	61706ZZ	
	42	7	4.41	2.85	15200	0.027	-	61806-2RZ	
	42	7	4.41	2.85	9025	0.027	-	61806-2RS	
	47	9	7.14	4.46	14250	0.051	-	61906-2RZ	
	47	9	7.14	4.46	8075	0.051	-	61906-2RS	
	55	13	13.53	8.14	13300	0.12	6006-Z	6006-ZZ	
	55	13	13.53	8.14	13300	0.12	6006-RZ	6006-2RZ	
	55	13	13.53	8.14	7600	0.12	6006-RS	6006-2RS	
	55	19	13.04	8.14	7600	0.16	-	63006-2RS	
	62	16	19.9	10.98	11400	0.2	6206-Z	6206-ZZ	
	62	16	19.9	10.98	11400	0.2	6206-RZ	6206-2RZ	
	62	16	19.9	10.98	7125	0.2	6206-RS	6206-2RS	
	62	20	19.11	10.98	7125	0.24	-	62206-2RS	
	72	19	29.01	15.68	10450	0.35	6306-Z	6306-ZZ	
	72	19	29.01	15.68	10450	0.35	6306-RZ	6306-2RZ	
	72	19	29.01	15.68	5985	0.35	6306-RS	6306-2RS	
72	27	27.54	15.68	5985	0.48	-	62306-2RS		
35	44	5	155	130	14000	0.03	-	61707ZZ	
	47	7	4.66	3.14	13300	0.03	-	61807-2RZ	
	47	7	4.66	3.14	7600	0.03	-	61807-2RS	
	55	10	9.37	6.67	12350	0.08	-	61907-2RZ	
	55	10	9.37	6.67	7125	0.08	-	61907-2RS	
	62	14	16.47	10	11400	0.16	6007-Z	6007-ZZ	
	62	14	16.47	10	11400	0.16	6007-RZ	6007-2RZ	
	62	14	16.47	10	6650	0.16	6007-RS	6007-2RS	
	62	20	15.59	10	6650	0.21	-	63007-2RS	
	72	17	26.46	15	9500	0.29	6207-Z	6207-ZZ	
	72	17	26.46	15	5985	0.29	6207-RS	6207-2RS	
	72	23	24.99	15	5985	0.37	-	62207-2RS	
	80	21	34.4	18.62	9025	0.46	6307-Z	6307-ZZ	
	80	21	34.4	18.62	5700	0.46	6307-RS	6307-2RS	
	80	31	32.54	18.62	5700	0.66	-	62307-2RS	
	40	50	6	207	177	13000	0.034	-	61708ZZ
		52	7	4.85	3.39	12350	0.034	-	61808-2RZ
52		7	4.85	3.39	7125	0.034	-	61808-2RS	
62		12	13.53	9.8	11400	0.12	-	61908-2RZ	
62		12	13.53	9.8	6365	0.12	-	61908-2RS	
68		15	17.45	11.37	10450	0.19	6008-Z	6008-ZZ	

* Para los rodamientos blindados sólo de un lado son válidas las velocidades límite de los rodamientos abiertos
* For one side shield bearings speed limit, use the same value of open bearings

RODAMIENTOS RÍGIDOS DE UNA HILERA DE BOLAS, BLINDADOS SEALED RADIAL DEEP GROOVE BALL BEARINGS

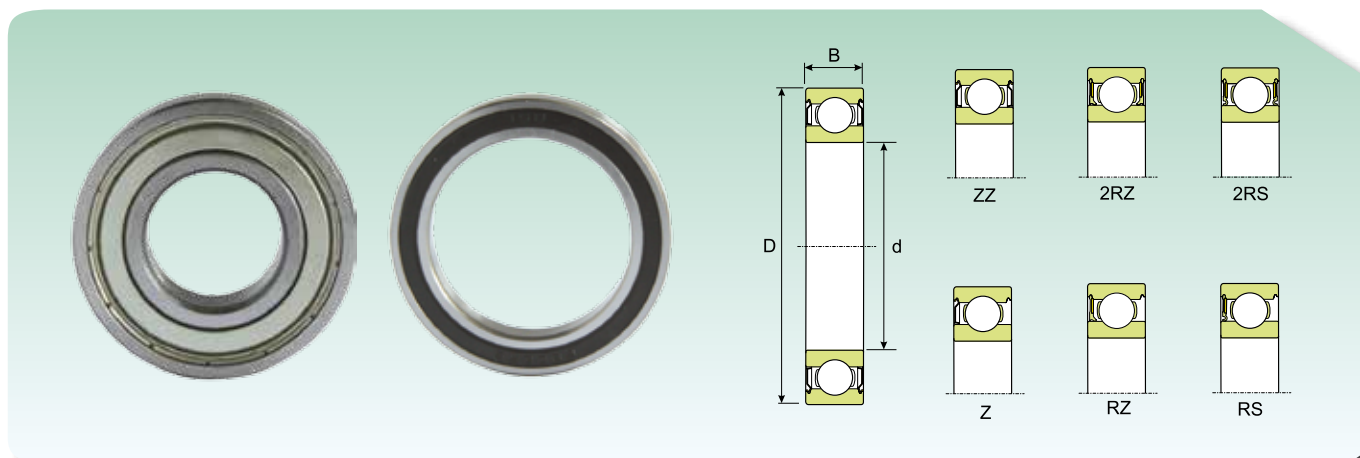

Dimensiones (mm) Dimension (mm)			Coeficiente de carga (KN) Load rating (KN)		Velocidad límite* Speed limit*	Peso (Kg) Weight (Kg)	Sigla Designation	
d (mm)	D (mm)	B (mm)	Dinámico Dynamic C	Estático Static C ₀			Blindaje de un lado One side shield	Blindaje en ambos lados Two side shield
40	68	15	17.45	11.37	10450	0.19	6008-RZ	6008-2RZ
	68	15	17.45	11.37	5985	0.19	6008-RS	6008-2RS
	68	21	16.47	11.37	5985	0.26	-	63008-2RS
	80	18	31.85	18.62	8550	0.37	6208-RZ	6208-2RZ
	80	18	31.85	18.62	8550	0.37	6208-Z	6208-ZZ
	80	18	31.85	18.62	5320	0.37	6208-RS	6208-2RS
	80	23	30.09	18.62	5320	0.44	-	62208-2RS
	90	23	41.46	23.52	8075	0.63	6308-Z	6308-ZZ
	90	23	41.46	23.52	8075	0.63	6308-RZ	6308-2RZ
	90	23	41.46	23.52	4750	0.63	6308-RS	6308-2RS
90	33	40.18	23.52	4750	0.89	-	62308-2RS	
45	55	6	213	192	12000	0.04	-	61709-ZZ
	58	7	6.5	5.98	10450	0.04	-	61809-2RZ
	58	7	6.5	5.98	6365	0.04	-	61809-2RS
	68	12	13.72	10.59	9500	0.14	-	61909-2RZ
	68	12	13.72	10.59	5700	0.14	-	61909-2RS
	75	16	21.66	14.31	9500	0.25	6009-Z	6009-ZZ
	75	16	21.66	14.31	5320	0.25	6009-RS	6009-2RS
	75	23	20.39	14.31	5320	0.34	-	63009-2RS
	85	19	34.4	21.17	8075	0.41	6209-Z	6209-ZZ
	85	19	34.4	21.17	4750	0.41	6209-RS	6209-2RS
	85	23	32.54	21.17	4750	0.48	-	62209-2RS
	100	25	54.2	30.87	7125	0.83	6309-Z	6309-ZZ
	100	25	54.2	30.87	4275	0.83	6309-RS	6309-2RS
100	36	51.65	30.87	4275	1.15	-	62309-2RS	
50	65	7	6.63	6.67	9500	0.052	-	61810-2RZ
	65	7	6.63	6.67	5700	0.052	-	61810-2RS
	72	12	14.31	11.57	9025	0.14	-	61910-2RZ
	72	12	14.31	11.57	5320	0.14	-	61910-2RS
	80	16	22.45	15.68	8550	0.26	6010-Z	6010-ZZ
	80	16	22.45	15.68	8550	0.26	6010-RZ	6010-2RZ
	80	16	22.45	15.68	4750	0.26	6010-RS	6010-2RS
	80	23	21.17	15.68	4750	0.37	-	63010-2RS
	90	20	36.36	22.74	7600	0.46	6210-Z	6210-ZZ
	90	20	36.36	22.74	7600	0.46	6210-RZ	6210-2RZ
	90	20	36.36	22.74	4560	0.46	6210-RS	6210-2RS
	90	23	34.4	22.74	4560	0.52	-	62210-2RS
	110	27	63.7	37.24	6365	1.05	6310-Z	6310-ZZ
110	27	63.7	37.24	4085	1.05	6310-RS	6310-2RS	
110	40	60.57	37.24	4085	1.55	-	62310-2RS	
55	72	9	8.86	8.63	9025	0.083	-	61811-2RZ
	72	9	8.86	8.63	5035	0.083	-	61811-2RS
	80	13	16.17	13.72	8075	0.19	-	61911-2RZ
	80	13	16.17	13.72	4750	0.19	-	61911-2RS
	90	18	29.01	20.78	7600	0.39	6011-Z	6011-ZZ
	90	18	29.01	20.78	4275	0.39	6011-RS	6011-2RS
	100	21	45.28	28.42	6650	0.61	6211-Z	6211-ZZ

* Para los rodamientos blindados sólo de un lado son válidas las velocidades límite de los rodamientos abiertos
* For one side shield bearings speed limit, use the same value of open bearings

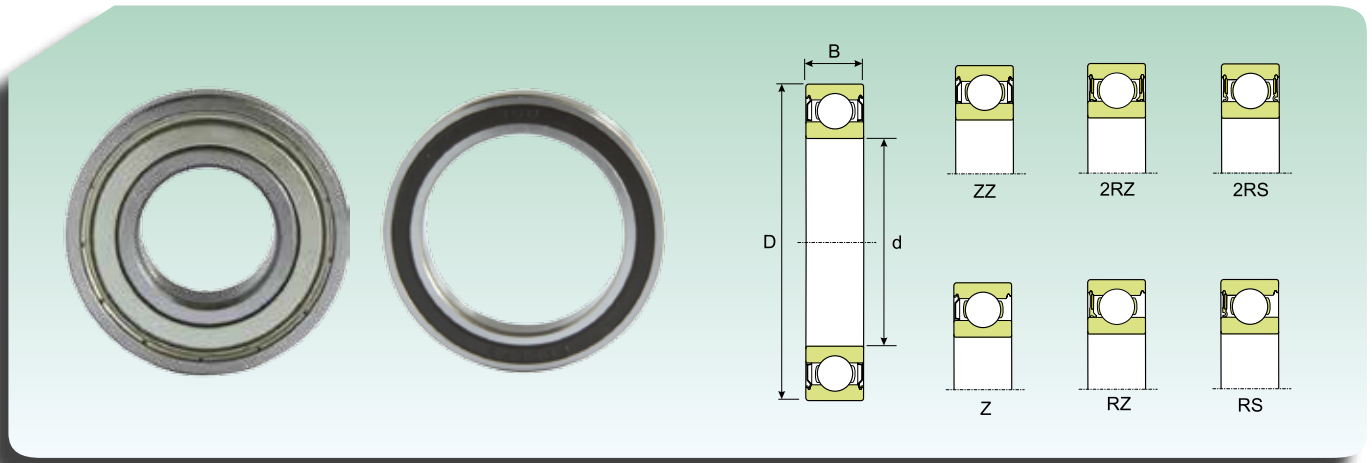
RODAMIENTOS RÍGIDOS DE UNA HILERA DE BOLAS, BLINDADOS
SEALED RADIAL DEEP GROOVE BALL BEARINGS

Dimensiones (mm) Dimension (mm)			Coeficiente de carga (KN) Load rating (KN)		Velocidad límite* Speed limit*	Peso (Kg) Weight (Kg)	Sigla Designation	
d (mm)	D (mm)	B (mm)	Dinámico Dynamic C	Estático Static C ₀			Blindaje de un lado One side shield	Blindaje en ambos lados Two side shield
55	100	21	45.28	28.42	4085	0.61	6211-RS	6211-2RS
	100	25	42.73	28.42	4085	0.7	-	62211-2RS
	120	29	72.62	44.1	5985	1.35	6311-Z	6311-ZZ
	120	29	72.62	44.1	3610	1.35	6311-RS	6311-2RS
	120	43	70.07	44.1	3610	1.95	-	62311-2RS
60	78	10	11.67	11.18	8075	0.11	-	61812-2RZ
	78	10	11.67	11.18	4560	0.11	-	61812-2RS
	85	13	16.17	14.02	7600	0.2	-	61912-2RZ
	85	13	16.17	14.02	4275	0.2	-	61912-2RS
	95	18	30.09	22.74	7125	0.42	6012-Z	6012-ZZ
	95	18	30.09	22.74	7125	0.42	6012-RZ	6012-2RZ
	95	18	30.09	22.74	4085	0.42	6012-RS	6012-2RS
60	110	22	54.2	35.28	5985	0.78	6212-Z	6212-ZZ
	110	22	54.2	35.28	3800	0.78	6212-RS	6212-2RS
	110	28	51.65	35.28	3800	0.97	-	62212-2RS
	130	31	83.5	50.96	5320	1.7	6312-Z	6312-ZZ
	130	31	83.5	50.96	3230	1.7	6312-2RS	6312-2RS
	130	46	80.27	50.96	3230	2.5	-	62312-2RS
65	85	10	12.16	12.45	7600	0.13	-	61813-2RZ
	85	10	12.16	12.45	4275	0.13	-	61813-2RS
	90	13	17.06	15.68	7125	0.22	-	61913-2RZ
	90	13	17.06	15.68	4085	0.22	-	61913-2RS
	100	18	31.27	24.5	6650	0.44	6013-Z	6013-ZZ
	100	18	31.27	24.5	3800	0.44	6013-RS	6013-2RS
	120	23	57.33	39.69	5700	0.99	6213-Z	6213-ZZ
	120	23	57.33	39.69	3420	0.99	6213-RS	6213-2RS
	120	31	54.79	39.69	3420	1.25	-	62213-2RS
	140	33	95.55	58.8	5035	2.1	6313-Z	6313-ZZ
	140	33	95.55	58.8	3040	2.1	6313-RS	6313-2RS
140	48	90.46	58.8	3040	3	-	62313-2RS	
70	90	10	12.16	12.94	7125	0.14	-	61814-2RZ
	90	10	12.16	12.94	4085	0.14	-	61814-2RS
	100	16	23.33	20.78	6650	0.35	-	61914-2RZ
	100	16	23.33	20.78	3800	0.35	-	61914-2RS
	110	20	38.91	30.38	5985	0.6	6014-Z	6014-ZZ
	110	20	38.91	30.38	3420	0.6	6014-RS	6014-2RS
	125	24	62.43	44.1	5320	1.1	6214-Z	6214-ZZ
	125	24	62.43	44.1	3230	1.1	6214-RS	6214-2RS
	125	31	59.29	44.1	3230	1.3	-	62214-2RS
	150	35	108.78	66.64	4750	2.5	6314-Z	6314-ZZ
	150	35	108.78	66.64	2850	2.5	6314-RS	6314-2RS
	150	51	101.92	66.64	2850	3.55	-	62314-2RS
	75	95	10	12.45	14.02	6650	0.15	-
95		10	12.45	14.02	3800	0.15	-	61815-2RS
105		16	23.72	18.92	5985	0.37	-	61915-2RZ
105		16	23.72	18.92	3420	0.37	-	61915-2RS

* Para los rodamientos blindados sólo de un lado son válidas las velocidades límite de los rodamientos abiertos
 * For one side shield bearings speed limit, use the same value of open bearings

RODAMIENTOS RÍGIDOS DE UNA HILERA DE BOLAS, BLINDADOS
SEALED RADIAL DEEP GROOVE BALL BEARINGS

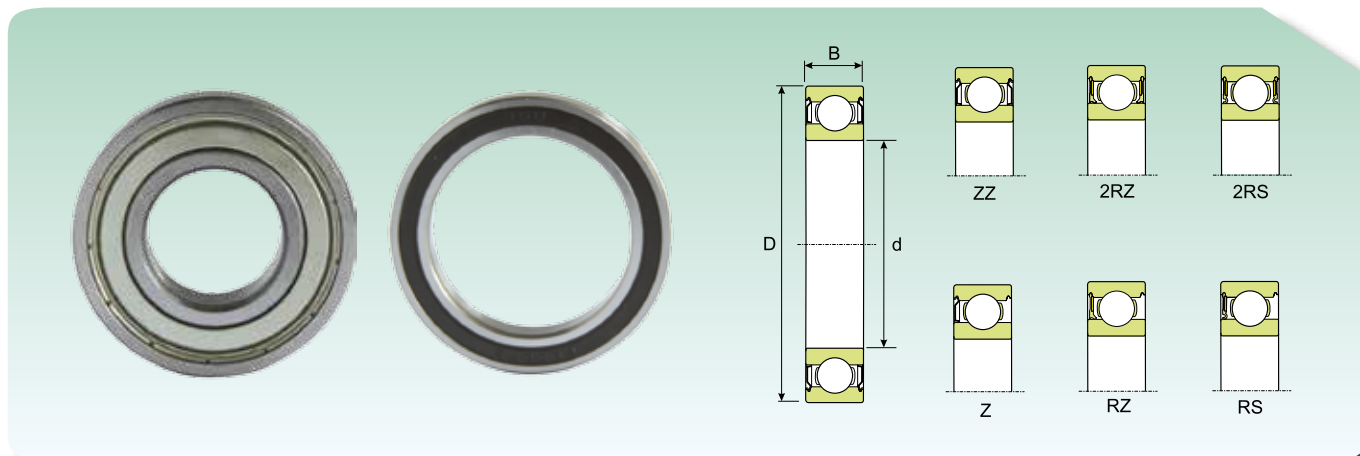

Dimensiones (mm) Dimension (mm)			Coeficiente de carga (KN) Load rating (KN)		Velocidad límite* Speed limit*	Peso (Kg) Weight (Kg)	Sigla Designation	
d (mm)	D (mm)	B (mm)	Dinámico Dynamic C	Estático Static C ₀			Blindaje de un lado One side shield	Blindaje en ambos lados Two side shield
75	115	20	40.77	32.83	5700	0.64	6015-Z	6015-ZZ
	115	20	40.77	32.83	5700	0.64	6015-RZ	6015-2RZ
	115	20	40.77	32.83	3230	0.64	6015-RS	6015-2RS
	130	25	67.53	48.02	5035	1.2	6215-Z	6215-ZZ
	130	25	67.53	48.02	3040	1.2	6215-RS	6215-2RS
	160	37	116.62	74.97	4275	3	6315-Z	6315-ZZ
	160	37	116.62	74.97	2660	3	6315-RS	6315-2RS
80	100	10	12.8	14.7	5985	0.15	-	61816-2RZ
	100	10	12.8	14.7	3420	0.15	-	61816-2RS
	110	16	24.6	20	5700	0.4	-	61916-2RZ
	110	16	24.6	20	3230	0.4	-	61916-2RS
	125	22	48.5	39.2	3040	0.85	6016-RS	6016-2RS
	140	26	71.4	53.9	4560	1.4	6216-Z	6216-ZZ
	125	22	48.5	39.2	5320	0.85	6016-Z	6016-ZZ
	140	26	71.4	53.9	2850	1.4	6216-RS	6216-2RS
	170	39	127.4	84.8	4085	3.6	6316-Z	6316-ZZ
	170	39	127.4	84.8	2470	3.6	6316-RS	6316-2RS
85	110	13	19.2	20.4	5700	0.27	-	61817-2RZ
	110	13	19.2	20.4	3230	0.27	-	61817-2RS
	130	22	51	42.2	5035	0.89	6017-Z	6017-ZZ
	130	22	51	42.2	2850	0.89	6017-RS	6017-2RS
	150	28	85.4	62.8	4275	1.8	6217-Z	6217-ZZ
	150	28	85.4	62.8	2660	1.8	6217-RS	6217-2RS
	180	41	137.2	94.6	3800	4.25	6317-Z	6317-ZZ
180	41	137.2	94.6	2280	4.25	6317-RS	6317-2RS	
90	115	13	19.2	21.6	5320	0.28	-	61818-2RZ
	115	13	19.2	21.6	3040	0.28	-	61818-2RS
	140	24	59.3	49	4750	1.15	6018-Z	6018-ZZ
	140	24	59.3	49	2660	1.15	6018-RS	6018-2RS
	160	30	99	72.1	4085	2.15	6218-Z	6218-ZZ
	160	30	99	72.1	2470	2.15	6218-RS	6218-2RS
	190	43	148	105.9	3610	4.9	6318-Z	6318-ZZ
	190	43	148	105.9	2280	4.9	6318-RS	6318-2RS
95	120	13	19.6	22.4	5035	0.3	-	61819-2RZ
	120	13	19.6	22.4	2850	0.3	-	61819-2RS
	130	18	33.2	32.9	2850	0.61	-	61919-2RS
	145	24	62.5	53	4560	1.2	6019-Z	6019-ZZ
	145	24	62.5	53	2660	1.2	6019-RS	6019-2RS
	170	32	111.8	79.9	3800	2.6	6219-Z	6219-ZZ
	170	32	111.8	79.9	2280	2.6	6219-RS	6219-2RS
	200	45	155.9	115.7	3420	5.65	6319-Z	6319-ZZ
	200	45	155.9	115.7	2090	5.65	6319-RS	6319-2RS

* Para los rodamientos blindados sólo de un lado son válidas las velocidades límite de los rodamientos abiertos
 * For one side shield bearings speed limit, use the same value of open bearings

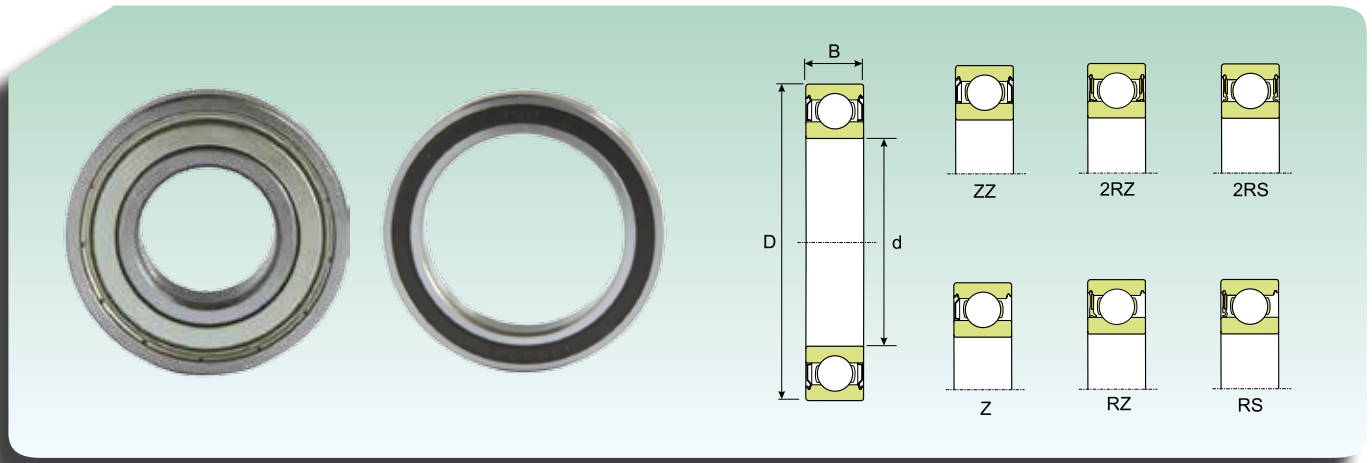
RODAMIENTOS RÍGIDOS DE UNA HILERA DE BOLAS, BLINDADOS
SEALED RADIAL DEEP GROOVE BALL BEARINGS

Dimensiones (mm) Dimension (mm)			Coeficiente de carga (KN) Load rating (KN)		Velocidad límite* Speed limit*	Peso (Kg) Weight (Kg)	Sigla Designation	
d (mm)	D (mm)	B (mm)	Dinámico Dynamic C	Estático Static C ₀			Blindaje de un lado One side shield	Blindaje en ambos lados Two side shield
100	125	13	19.6	23.6	5035	0.31	-	61820-2RZ
	125	13	19.6	23.6	2850	0.31	-	61820-2RS
	150	24	62.5	53	4275	1.25	6020-Z	6020-ZZ
	150	24	62.5	53	2470	1.25	6020-RS	6020-2RS
	180	34	124.5	91.2	3610	3.15	6220-Z	6220-ZZ
	180	34	124.5	91.2	2280	3.15	6220-RS	6220-2RS
105	130	13	20.4	19.3	4750	0.32	-	61821-2RZ
	130	13	20.4	19.3	2660	0.32	-	61821-2RS
	160	26	74.6	64.2	4085	1.6	6021-Z	6021-ZZ
	160	26	74.6	64.2	2280	1.6	6021-RS	6021-2RS
	190	36	137.2	102	3420	3.7	6221-Z	6221-ZZ
	190	36	137.2	102	2090	3.7	6221-RS	6221-2RS
110	225	49	178.4	150	3040	8.25	6321-Z	6321-ZZ
	140	16	27.6	25.5	4275	0.6	-	61822-2RZ
	140	16	27.6	25.5	2470	0.6	-	61822-2RS
	170	28	83.5	72.1	3800	1.95	6022-Z	6022-ZZ
	170	28	83.5	72.1	2280	1.95	6022-RS	6022-2RS
120	200	38	148	1095.7	3230	4.35	6222-Z	6222-ZZ
	150	16	28.6	27.5	4085	0.65	-	61824-2RZ
	150	16	28.6	27.5	2280	0.65	-	61824-2RS
	180	28	86.7	78.4	3610	2.05	6024-Z	6024-ZZ
	180	28	86.7	78.4	2090	2.05	6024-RS	6024-2RS
130	215	40	143.1	115.7	3040	5.15	6224-Z	6224-ZZ
	165	18	37	42.2	3610	0.93	-	61826-2RZ
	165	18	37	42.2	2090	0.93	-	61826-2RS
	200	33	109.8	98	3230	3.15	6026-Z	6026-ZZ
	200	33	109.8	98	1900	3.15	6026-RS	6026-2RS
140	230	40	152.9	129.4	2850	5.8	6226-Z	6226-ZZ
	175	18	38.3	45.6	3420	0.99	-	61828-2RZ
	175	18	38.3	45.6	1900	0.99	-	61828-2RS
	210	33	108.8	105.9	3040	3.35	6028-Z	6028-ZZ
150	210	33	108.8	105.9	1710	3.35	6028-RS	6028-2RS
	225	35	122.5	122.5	2850	4.8	6030-Z	6030-ZZ
160	225	35	122.5	122.5	1615	4.8	6030-RS	6030-2RS
	240	38	140.2	140.2	2660	5.9	6032-Z	6032-ZZ
160	240	38	140.2	140.2	1520	5.9	6032-RS	6032-2RS

* Para los rodamientos blindados sólo de un lado son válidas las velocidades límite de los rodamientos abiertos
 * For one side shield bearings speed limit, use the same value of open bearings

RODAMIENTOS RÍGIDOS DE UNA HILERA DE BOLAS, CON RANURADO PARA ARO DE FIJACIÓN
SEALED RADIAL DEEP GROOVE BALL BEARINGS, WITH SNAP RING

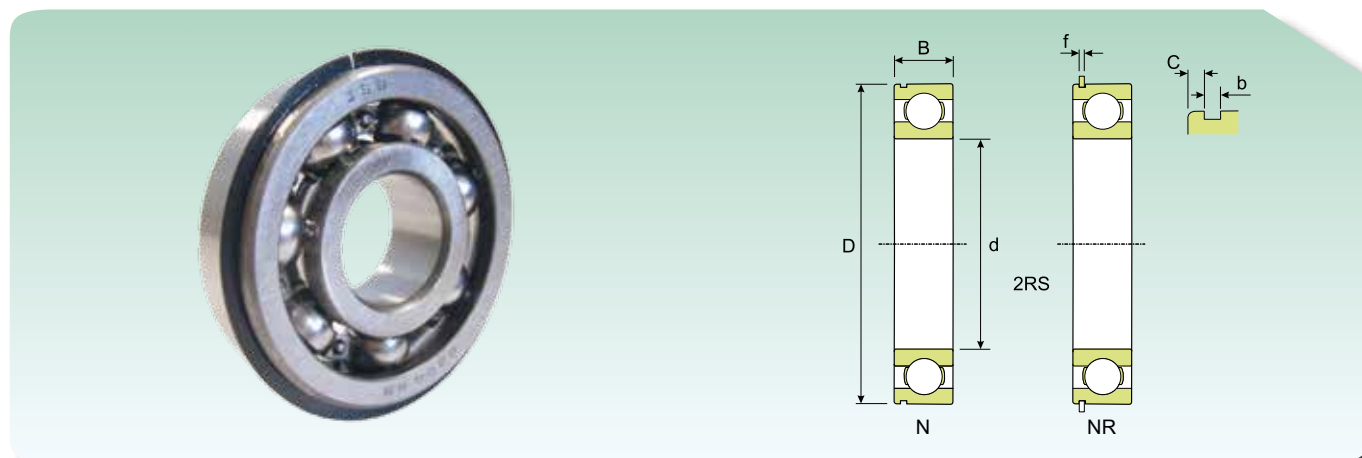

Dimensiones (mm) Dimension (mm)						Coeficiente de carga (KN) Load rating (KN)		Velocidad límite (rpm) Speed limit (Rpm)		Peso (Kg) Weight (Kg)	Sigla Designation		Aro de fijación Snap ring
d (mm)	D (mm)	B (mm)	b (mm)	C (mm)	f (mm)	Dinámico Dynamic C	Estático Static C ₀	Lubricación Lubrication			Con ranurado With snap ring groove	Con aro With locating snap ring	
								Grasa Grease	Aceite Oil				
10	30	9	1.35	2.06	1.12	5.3	2.32	26010	30600	0.032	6200 N	6200 NR	SP 30
12	32	10	1.35	2.06	1.12	7.14	3.04	24480	28800	0.037	6201 N	6201 NR	SP 32
15	35	11	1.35	2.06	1.12	7.9	3.68	21420	25200	0.045	6202 N	6202 NR	SP 35
17	40	12	1.35	2.06	1.12	9.76	4.66	18360	21600	0.065	6203 N	6203 NR	SP 40
	47	14	1.35	2.46	1.12	14.02	6.42	16830	19800	0.12	6303 N	6303 NR	SP 47
20	42	12	1.35	2.06	1.12	9.76	4.9	18360	21600	0.069	6004 N	6004 NR	SP 42
	47	14	1.35	2.46	1.12	13.23	6.42	15300	18000	0.11	6204 N	6204 NR	SP 47
	52	15	1.35	2.46	1.12	16.47	7.65	14535	17100	0.14	6304 N	6304 NR	SP 52
25	47	12	1.35	2.06	1.12	11.67	6.42	15300	18000	0.08	6005 N	6005 NR	SP 47
	52	15	1.35	2.46	1.12	14.51	7.65	13770	16200	0.13	6205 N	6205 NR	SP 52
	62	17	1.9	3.28	1.7	22.94	11.37	12240	14400	0.23	6305 N	6305 NR	SP 62
30	55	13	1.35	2.06	1.12	13.53	8.14	13005	15300	0.12	6006 N	6006 NR	SP 55
	62	16	1.9	3.28	1.7	19.9	10.98	11475	13500	0.2	6206 N	6206 NR	SP 62
	72	19	1.9	3.28	1.7	29.01	15.68	9945	11700	0.35	6306 N	6306 NR	SP 72
35	62	14	1.9	2.06	1.7	16.47	10	11475	13500	0.16	6007 N	6007 NR	SP 62
	72	17	1.9	3.28	1.7	26.46	15	9945	11700	0.29	6207 N	6207 NR	SP 72
	80	21	1.9	3.28	1.7	34.4	18.62	9180	10800	0.46	6307 N	6307 NR	SP 80
	100	25	2.7	3.28	2.46	54.2	30.38	7650	9000	0.95	6407 N	6407 NR	SP 100
40	68	15	1.9	2.49	1.7	17.45	11.37	10710	12600	0.19	6008 N	6008 NR	SP 68
	80	18	1.9	3.28	1.7	31.85	18.62	8415	9900	0.37	6208 N	6208 NR	SP 80
	90	23	2.7	3.28	2.46	41.46	23.52	8415	9900	0.63	6308 N	6308 NR	SP 90
	110	27	2.7	3.28	2.46	62.43	35.77	6885	8100	1.25	6408 N	6408 NR	SP 110
45	75	16	1.9	2.49	1.7	21.66	14.31	9180	10800	0.25	6009 N	6009 NR	SP 75
	85	19	1.9	3.28	1.7	34.4	21.17	8415	9900	0.41	6209 N	6209 NR	SP 85
	100	25	2.7	3.28	2.46	54.2	30.87	7268	8550	0.83	6309 N	6309 NR	SP 100
	120	29	3.1	4.06	2.82	74.58	44.1	6503	7650	1.55	6409 N	6409 NR	SP 120
50	80	16	1.9	2.49	1.7	22.45	15.68	8415	9900	0.26	6010 N	6010 NR	SP 80
	90	20	2.7	3.28	2.46	36.36	22.74	7650	9000	0.46	6210 N	6210 NR	SP 90
	110	27	2.7	3.28	2.46	63.7	37.24	6503	7650	1.05	6310 N	6310 NR	SP 110
	130	31	3.1		2.82	85.36	50.96	5738	6750	1.9	6410 N	6410 NR	SP 130
55	90	18	2.7	2.87	2.46	29.01	20.78	7650	9000	0.39	6011 N	6011 NR	SP 90
	100	21	2.7	3.28	2.46	45.28	28.42	6885	8100	0.61	6211 N	6211 NR	SP 100
	120	29	3.1	4.06	2.82	72.62	44.1	6120	7200	1.35	6311 N	6311 NR	SP 120
	140	33	3.1	4.9	2.82	97.51	60.76	5355	6300	2.3	6411 N	6411 NR	SP 140
60	95	18	2.7	2.87	2.46	30.09	22.74	7268	8550	0.42	6012 N	6012 NR	SP 95
	110	22	2.7	4.06	2.46	54.2	35.28	6120	7200	0.78	6212 N	6212 NR	SP 110
	130	31	3.1	4.9	2.82	83.5	50.96	5355	6300	1.7	6312 N	6312 NR	SP 130
	150	35	3.1	4.9	2.82	105.84	68.11	4820	5670	2.75	6412 N	6412 NR	SP 150

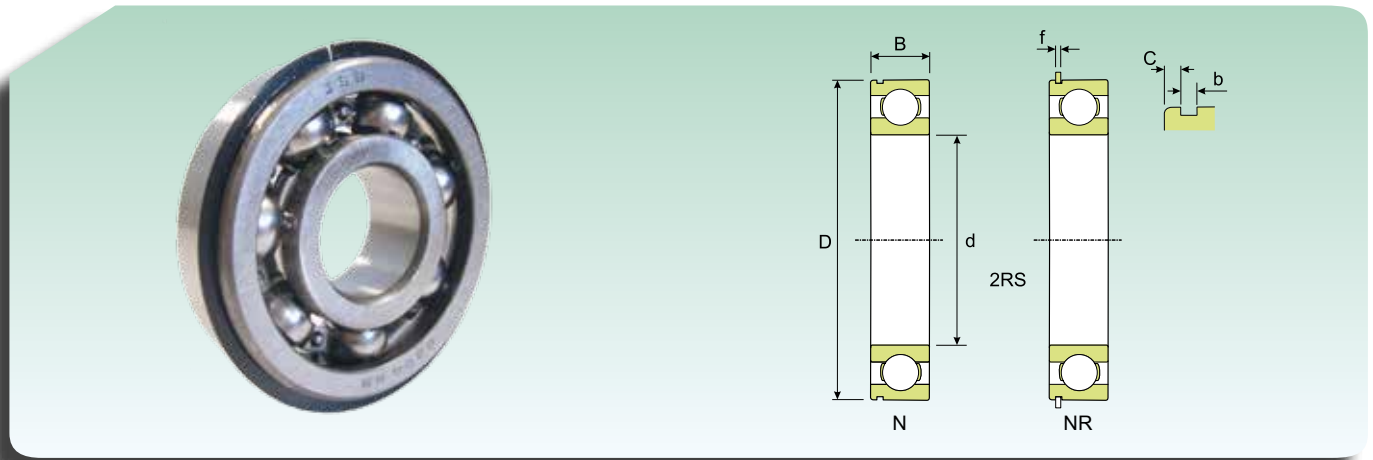
**RODAMIENTOS RÍGIDOS DE UNA HILERA DE BOLAS, CON RANURADO PARA ARO DE FIJACIÓN
SEALED RADIAL DEEP GROOVE BALL BEARINGS, WITH SNAP RING**

Dimensiones (mm) Dimension (mm)						Coeficiente de carga (KN) Load rating (KN)		Velocidad límite (rpm) Speed limit (Rpm)		Peso (Kg) Weight (Kg)	Sigla Designation		Aro de fijación Snap ring
d (mm)	D (mm)	B (mm)	b (mm)	C (mm)	f (mm)	Dinámico Dynamic C	Estático Static C ₀	Lubrificación Lubrication			Con ranurado With snap ring groove	Con aro With locating snap ring	
								Grasa Grease	Aceite Oil				
65	100	18	2.7	2.87	2.46	31.27	24.5	6885	8100	0.44	6013 N	6013 NR	SP 100
	120	23	3.1	4.06	2.82	57.33	39.69	5738	6750	0.99	6213 N	6213 NR	SP 120
	140	33	3.1	4.9	2.82	95.55	58.8	5126	6030	2.1	6313 N	6313 NR	SP 140
	160	37	3.1	4.9	2.82	116.62	76.44	4590	5400	3.3	6413 N	6413 NR	SP 160
70	110	20	2.7	2.87	2.46	38.91	30.38	6120	7200	0.6	6014 N	6014 NR	SP 110
	125	24	3.1	4.06	2.82	62.43	44.1	5355	6300	1.05	6214 N	6214 NR	SP 125
	150	35	3.1	4.9	2.82	108.78	66.64	4820	5670	2.5	6314 N	6314 NR	SP 150
75	115	20	2.7	2.87	2.46	40.77	32.83	5738	6750	0.64	6015 N	6015 NR	SP 115
	130	25	3.1	4.06	2.82	67.53	48.02	5126	6030	1.2	6215 N	6215 NR	SP 130
	160	37	3.1	4.9	2.82	116.62	74.97	4284	5040	3	6315 N	6315 NR	SP 160
80	125	22	3.1	2.87	2.82	48.42	39.2	5355	6300	0.85	6016 N	6016 NR	SP 125
	140	26	3.1	4.9	2.82	71.35	53.9	4590	5400	1.4	6216 N	6216 NR	SP 140
85	130	22	3.1	2.87	2.82	50.96	42.14	5126	6030	0.89	6017 N	6017 NR	SP 130
	150	28	3.1	4.9	2.82	85.36	62.72	4284	5040	1.8	6217 N	6217 NR	SP 150
90	140	24	3.1	3.71	2.82	59.29	49	4820	5670	1.15	6018 N	6018 NR	SP 140
	160	30	3.1	4.9	2.82	98.98	72.03	4055	4770	2.15	6218 N	6218 NR	SP 160
95	170	32	3.1	5.69	3.1	111.72	79.87	3825	4500	2.6	6219 N	6219 NR	SP 170
100	150	24	2.82	3.71	2.82	62.43	52.92	4284	5040	1.25	6020 N	6020 NR	SP 150
	180	34	3.1	5.69	3.1	124.46	91.14	3672	4320	3.15	6220 N	6220 NR	SP 180
105	160	26	2.82	3.71	2.82	74.58	64.19	4055	4770	1.6	6021 N	6021 NR	SP 160
110	170	28	3.1	3.71	3.1	83.5	72.03	3825	4500	1.95	6022 N	6022 NR	SP 170
120	180	28	3.1	3.71	3.1	86.64	78.4	3672	4320	2.05	6024 N	6024 NR	SP 180

RODAMIENTOS RÍGIDOS DE UNA HILERA DE BOLAS, BLINDADOS CON ARO DE FIJACIÓN RADIAL DEEP GROOVE BALL BEARINGS, SEALED WITH SNAP RING

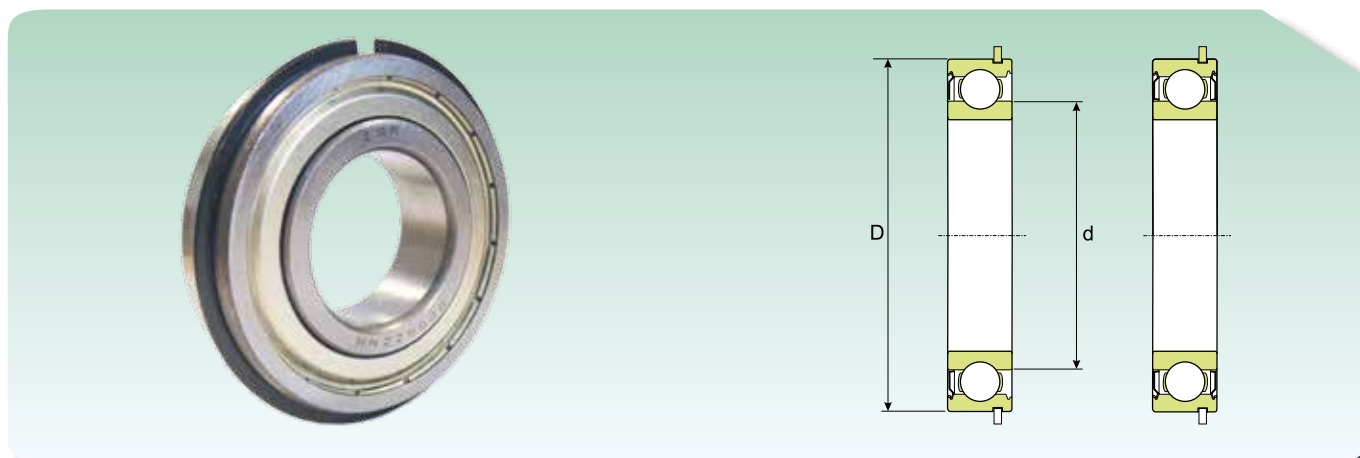

Dimensiones (mm) Dimension (mm)			Coeficiente de carga (KN) Load rating (KN)		Velocidad límite* Speed limit*	Peso (Kg) Weight (Kg)	Sigla Designation		Aro de fijación Snap ring
d (mm)	D (mm)	B (mm)	Dinámico Dynamic C	Estático Static C ₀			Abierto con blindaje en Open Shielded		
							Un lado One side shield	En ambos lados Two side shield	
10	30	9	5.3	2.32	32300	0.032	6200-ZNR	6200-ZZNR	SP 30
12	32	10	7.14	3.04	30400	0.037	6201-ZNR	6201-ZZNR	SP 32
15	35	11	7.9	3.68	26600	0.045	6202-ZNR	6202-ZZNR	SP 35
17	40	12	9.76	4.66	22800	0.065	6203-ZNR	6203-ZZNR	SP 40
	47	14	14.02	6.42	20900	0.12	6303-ZNR	6303-ZZNR	SP 47
20	42	12	9.76	4.9	22800	0.069	6004-ZNR	6004-ZZNR	SP 42
	47	14	13.23	6.42	19000	0.11	6204-ZNR	6204-ZZNR	SP 47
	52	15	16.47	7.65	18050	0.14	6304-ZNR	6304-ZZNR	SP 52
25	47	12	11.67	6.42	19000	0.08	6005-ZNR	6005-ZZNR	SP 47
	52	15	14.51	7.65	17100	0.13	6205-ZNR	6205-ZZNR	SP 52
	62	17	22.94	11.37	15200	0.23	6305-ZNR	6305-ZZNR	SP 62
30	62	16	19.9	10.98	14250	0.2	6206-ZNR	6206-ZZNR	SP 62
	72	19	29.01	15.68	12350	0.35	6306-ZNR	6306-ZZNR	SP 72
35	72	17	26.46	15	12350	0.29	6207-ZNR	6207-ZZNR	SP 72
	80	21	34.4	18.62	11400	0.46	6307-ZNR	6307-ZZNR	SP 80
40	80	18	31.85	18.62	10450	0.37	6208-ZNR	6208-ZZNR	SP 80
	90	23	41.46	23.52	10450	0.63	6308-ZNR	6308-ZZNR	SP 90
45	85	19	34.4	21.17	10450	0.41	6209-ZNR	6209-ZZNR	SP 85
	100	25	54.2	30.87	9025	0.83	6309-ZNR	6309-ZZNR	SP 100
50	90	20	36.36	22.74	9500	0.46	6210-ZNR	6210-ZZNR	SP 90
	110	27	63.7	37.24	8075	1.05	6310-ZNR	6310-ZZNR	SP 110
55	100	21	45.28	28.42	8550	0.61	6211-ZNR	6211-ZZNR	SP 100
	120	29	72.62	44.1	7600	1.35	6311-ZNR	6311-ZZNR	SP 120
60	110	22	54.2	35.28	7600	0.78	6212-ZNR	6212-ZZNR	SP 110
	130	31	83.5	50.96	6650	1.7	6312-ZNR	6312-ZZNR	SP 130
65	120	23	57.33	39.69	7125	0.99	6213-ZNR	6213-ZZNR	SP 120
	140	33	95.55	58.8	6365	2.1	6313-ZNR	6313-ZZNR	SP 140
70	125	24	62.43	44.1	6650	1.05	6214-ZNR	6214-ZZNR	SP 125
	150	35	108.78	66.64	5985	2.5	6314-ZNR	6314-ZZNR	SP 150

* Para los rodamientos blindados sólo de un lado son válidas las velocidades límite de los rodamientos abiertos
* For one side shield bearings speed limit, use the same value of open bearings





**Rodamientos rígidos de una hilera de bolas
de acero inoxidable**

Radial stainless steel deep groove ball bearings



RODAMIENTOS RÍGIDOS DE UNA HILERA DE BOLAS DE ACERO INOXIDABLE

Los rodamientos **ISB**[®] rígidos de bolas de acero inoxidable resisten perfectamente a la corrosión provocada por la humedad. Este tipo específico de rodamiento rígido tiene las mismas características que el estándar de acero al cromo, por lo tanto encontraremos las mismas ranuras profundas y a elevados contactos. Sin escote de llenado, resisten a cargas axiales que inciden en las dos direcciones sumadas a cargas radiales, también en presencia de altas velocidades. Los rodamientos **ISB**[®] rígidos de bolas de acero inoxidable tienen las mismas características de funcionamiento que los rodamientos estándares con menor capacidad de carga. Los rodamientos **ISB**[®] rígidos de bolas de acero inoxidable se identifican con el prefijo SS.

RODAMIENTOS ESTÁNDAR

Los rodamientos estándares **ISB**[®] se denominan abiertos cuando no tienen juntas laterales (**Fig. 1**).

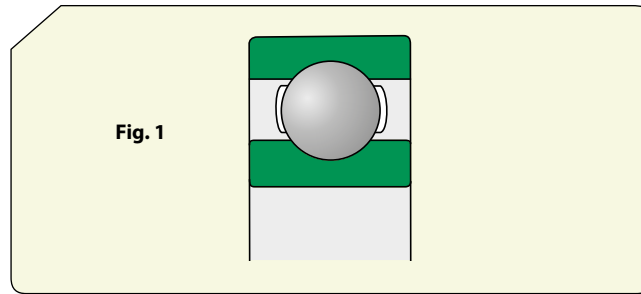

STAINLESS STEEL SINGLE ROW DEEP GROOVE RADIAL BALL BEARINGS

***ISB**[®] stainless steel deep groove radial ball bearings are perfectly resistant to corrosion caused through moisture. This specific type of deep groove bearing has the same characteristics as the standard chromium steel bearing, therefore it has the same deep grooves and close conformities. They have no filling slots and withstand axial loads acting in both directions in addition to radial loads, even at high speeds. **ISB**[®] stainless steel deep groove radial ball bearings have the same operational characteristics as standard bearings but have a lower load carrying capacity. **ISB**[®] stainless steel deep groove radial ball bearings are identified with the designation prefix SS.*

STANDARD BEARINGS

*The standard bearings of **ISB**[®] are open, because they have no seals at the sides (**Fig. 1**).*

RODAMIENTOS CON JUNTAS INCORPORADAS

Buena parte de los rodamientos **ISB**[®] rígidos de bolas de acero inoxidable están disponibles en dos versiones, blindada y con juntas deslizantes. Dichos tipos de rodamientos están lubricados de por vida, no necesitan ningún mantenimiento y no deben ser lavados ni calentados a temperaturas superiores a 80°C. La cantidad de grasa ocupa del 20% al 30% del espacio libre del rodamiento. La grasa en los rodamientos **ISB**[®] rígidos de bolas de acero inoxidable se podrá requerir atóxica, ya que este tipo específico de rodamiento se utiliza generalmente en aplicaciones alimenticias. Antes de efectuar el pedido verificar la disponibilidad de los rodamientos con grasa atóxica.

RODAMIENTOS BLINDADOS

La utilización de la sigla ZZ permite reconocer inmediatamente los rodamientos **ISB**[®] blindados de acero inoxidable. Los blindajes están compuestos de chapa de acero, su agujero crea un laberinto con la superficie cilíndrica externa del aro interno (**Fig. 2**).

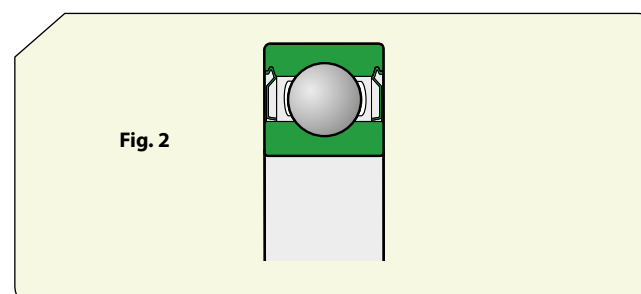

SEALED BEARINGS

*Most of the **ISB**[®] stainless steel deep groove radial ball bearings are available in two versions: with shields and with contact seals. These types of bearings are lubricated for life and are maintenance-free. They should not be washed or heated to temperatures beyond 80°C. The quantity of grease used fills 20% to 30% of the free space of the bearing. The grease used in **ISB**[®] stainless steel deep groove bearings may have to be the non-toxic type because this specific type of bearing is usually used in food processing applications. Please check availability of bearings with non-toxic grease before placing any orders.*

SHIELDED BEARINGS

*The shielded stainless steel bearings of **ISB**[®] are immediately recognisable by their designation suffix ZZ. The shields are made of sheet steel and their bore creates a labyrinth with the external cylindrical surface of the inner ring (**Fig. 2**).*

Los rodamientos blindados se emplean en las aplicaciones en las que el aro interno gira. En el caso que gire el aro externo, se corre el riesgo, sobre todo a altas velocidades, que salga grasa del rodamiento.

RODAMIENTOS CON BLINDAJES DESLIZANTES

El sufijo indicativo de los rodamientos con blindaje deslizante es 2RS (Fig. 3). Las juntas de los 2RS son de goma acrilonitrilo-butadieno (NBR) y reforzadas con una chapa.

El diámetro externo de esta junta está inserido en un ranurado del aro externo que lo retiene en posición sin deformaciones garantizando al mismo tiempo buenos resultados de durabilidad. Las temperaturas de empleo serán de -40°C a +100°C con picos, sólo por breves períodos, que llegan hasta +120°C. Velocidades, temperaturas muy elevadas u otras condiciones de trabajo difíciles pueden causar salida de grasa por las juntas.

Shielded bearings are used primarily in applications where the inner ring rotates. If it is the outer ring that rotates, there is the risk that grease may leak from the bearing, especially at high speeds.

BEARINGS WITH CONTACT SHIELDS

Bearings with contact shields have designation suffix 2RS (Fig. 3). The seals of the 2RS bearings are made of Nitrile-Butadiene-Rubber (NBR) with sheet metal reinforcement.

The outside diameter of this seal sits in a recess in the outer ring that holds it in position without deforming it, providing a good seal at the same time.

The operating temperatures will be from -40°C to +100°C with peaks up to +120°C for short periods only.

Excessive speeds and temperatures or other harsh working conditions could cause grease to leak from the seals.

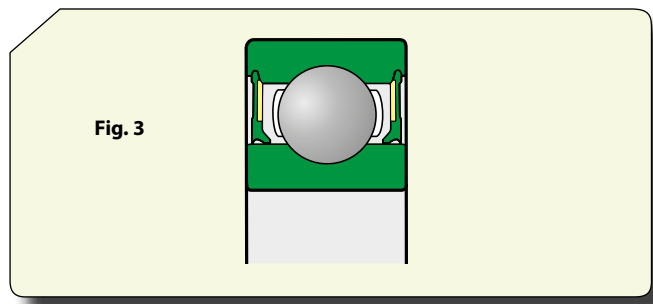

DIMENSIONES

Las dimensiones generales de los rodamientos ISB® rígidos de bolas de acero inoxidable respetan la norma ISO 15:1998.

TOLERANCIAS

Los rodamientos ISB® rígidos de bolas de acero inoxidable se fabrican con tolerancias Normales, de conformidad con la norma ISO 492:2002.

JUEGO INTERNO

Los rodamientos ISB® rígidos de bolas de acero inoxidable se fabrican con un juego interno Normal, de conformidad con la norma ISO 5753:1991.

MATERIALES

Las bolas y los aros de los rodamientos ISB® son de acero inoxidable AISI 440C, los blindajes y las jaulas de acero inoxidable AISI 302.

DESALINEACIÓN

La desalineación angular admisible, es decir aquella desalineación que no genera ulteriores sollicitaciones inaceptables depende de cuatro factores:

- juego interno radial del rodamiento en las condiciones de servicio;
- dimensiones;
- forma constructiva interna;
- carga y movimientos a los que está sujeto.

Cada desalineación que se verifica causa pérdida de silenciosidad y reducción de la vida del rodamiento. No es posible

DIMENSIONS

The overall dimensions of ISB® stainless steel deep groove radial ball bearings comply with standard ISO 15:1998.

TOLERANCES

ISB® stainless steel deep groove radial ball bearings are manufactured pursuant to Normal tolerances. The tolerance values comply with standard ISO 492:2002.

INTERNAL CLEARANCE

ISB® stainless steel deep groove radial ball bearings are manufactured with Normal internal radial clearance, pursuant to standard ISO 5753:1991.

MATERIALS

The balls and the rings of ISB® bearings are made of stainless steel AISI 440C, the shields and the cages are made of stainless steel AISI 302.

MISALIGNMENT

The admitted angular misalignment, being a misalignment that does not produce unacceptable additional strain, depends on four factors:

- *The internal radial clearance of the bearing in the operating conditions.*
- *The size of the bearing.*
- *The internal constructional design.*
- *The loads and the movements acting on the bearing.*

Misalignment will result in increased noise of the bearing and will reduce its life span. It is impossible to draft a table with

hacer una tabla con valores específicos de referencia porque las relaciones entre los citados factores son muy complejas.

JAULAS

Los rodamientos **ISB**[®] de bolas de acero inoxidable cuentan con una de las siguientes jaulas de acero inoxidable:

- Jaula estampada de acero inoxidable del tipo a presión, centrada en las bolas, ningún sufijo en el nombre (**Fig. 4a**);
- Jaula obtenida a partir de cinta de acero inoxidable centrada en las bolas, ningún sufijo en el nombre (**Fig. 4b**);
- Jaula estampada de acero inoxidable remachada, centrada en las bolas, ningún sufijo en el nombre (**Fig. 4c**);

specific reference values because the relationships between these four factors just mentioned are too complex.

CAGES

*Stainless steel **ISB**[®] bearings (**Fig. 4**) are fitted with one of the following stainless steel cages:*

- *Pressed snap-type stainless steel cage, centred on the balls, without any designation suffix (**Fig. 4a**).*
- *Pressed ribbon-type sheet stainless steel cage, centred on the balls, without any designation suffix (**Fig. 4b**);*
- *Pressed riveted stainless steel cage, centred on the balls, without any designation suffix (**Fig. 4c**);*

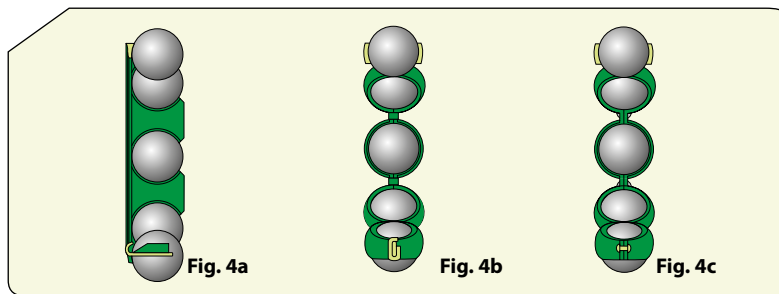

CARGA MÍNIMA

La carga mínima es de vital importancia para garantizar un funcionamiento correcto. Cualquier tipo de rodamiento deben estar sujeto a una cierta carga mínima. En los casos en que exista rotación a altas velocidades, aceleraciones elevadas o repentinos cambios de dirección, las fuerzas de inercia de las bolas y de las jaulas, la fricción del lubricante, influyen negativamente sobre las condiciones del sistema rodamiento, provocando deslizamientos perjudiciales entre las bolas y los caminos de rodadura.

MINIMUM LOAD

The minimum load is of vital importance guarantee efficient operation. All rolling bearings must be subjected to a certain minimum load. If they are to operate at high rotation speeds, high accelerations or sudden changes in direction, the inertia forces of the balls and of the cages and the friction of the lubricant have a detrimental effect on the conditions of the bearing arrangement and may cause harmful contact between the balls and the raceways.

CAPACIDAD CARGA AXIAL

Si los rodamientos **ISB**[®] rígidos de bolas de acero inoxidable se someten a una carga axial, esta no debe superar un valor de C0 0.25. Cargas superiores pueden causar reducción de la vida del rodamiento.

AXIAL LOAD CARRYING CAPACITY

If **ISB**[®] stainless steel deep groove radial ball bearings are subjected to an axial load, the latter must not exceed a C0 value of 0.25. Higher loads may reduce the bearing life span.

RODAMIENTOS RÍGIDOS DE UNA HILERA DE BOLAS DE ACERO INOXIDABLE RADIAL STAINLESS STEEL DEEP GROOVE BALL BEARINGS

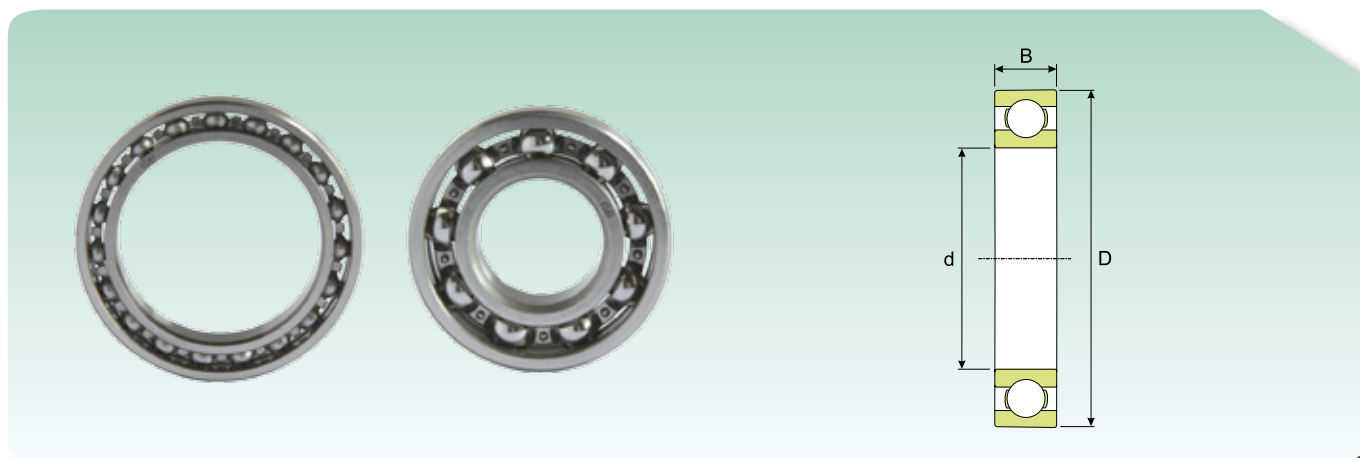

Dimensiones (mm) Dimension (mm)			Coeficiente de carga (KN) Load rating (KN)		Velocidad límite (rpm) Speed limit (Rpm)		Peso (Kg) Weight (Kg)	Sigla Designation
d (mm)	D (mm)	B (mm)	Dinámico Dynamic C	Estático Static C ₀	Lubrificación Lubrication			
					Grasa Grease	Aceite Oil		
1	3	1	0.055	0.017	114750	135000	0.000036	SS 618/1
2	5	1.5	0.153	0.047	91800	108000	0.00015	SS 618/2
3	6	3	0.212	0.083	76500	90000	0.00035	SS 637/3
	10	4	0.382	0.126	61200	72000	0.0016	SS 623
4	9	2.5	0.440	0.170	65025	76500	0.0007	SS 618/4
	11	4	0.593	0.220	61200	72000	0.0019	SS 619/4
	12	4	0.662	0.265	57375	67500	0.0024	SS 604
	13	5	0.777	0.274	51255	60300	0.0031	SS 624
5	11	3	0.529	0.240	57375	67500	0.0012	SS 618/5
	13	4	0.726	0.319	51255	60300	0.0023	SS 619/5
	16	5	0.905	0.358	45900	54000	0.005	SS 625
	19	6	1.823	0.897	38250	45000	0.009	SS 635
6	13	3.5	0.726	0.328	51255	60300	0.002	SS 618/6
	15	5	1.019	0.446	48195	56700	0.0039	SS 619/6
	19	6	1.823	0.897	38250	45000	0.0084	SS 626
7	14	3.5	0.790	0.382	48195	56700	0.0022	SS 618/7
	17	5	1.215	0.529	42840	50400	0.0049	SS 619/7
	19	6	1.823	0.897	40545	47700	0.0075	SS 607
	22	7	2.705	1.294	34425	40500	0.013	SS 627
8	16	4	1.098	0.539	42840	50400	0.003	SS 618/8
	19	6	1.558	0.696	38250	45000	0.0071	SS 619/8
	22	7	2.705	1.294	36720	43200	0.012	SS 608
9	17	4	1.166	0.608	40545	47700	0.0034	SS 618/9
	20	6	1.705	0.813	36720	43200	0.0076	SS 619/9
	24	7	3.058	1.568	32895	38700	0.014	SS 609
	26	8	3.822	1.862	29070	34200	0.02	SS 629
10	15	3	0.701	0.417	42840	50400	0.0014	SS 61700
	19	5	1.117	0.559	36720	43200	0.0055	SS 61800
	22	6	1.705	0.799	34425	40500	0.01	SS 61900
	26	8	3.822	1.862	30600	36000	0.019	SS 6000
	30	9	4.145	2.234	26010	30600	0.032	SS 6200
	35	11	6.625	3.185	24480	28800	0.053	SS 6300
12	21	5	1.186	0.627	32895	38700	0.0063	SS 61801
	24	6	1.862	0.931	30600	36000	0.011	SS 61901
	28	8	4.145	2.234	29070	34200	0.022	SS 6001
	32	10	5.733	2.940	24480	28800	0.037	SS 6201
	37	12	8.026	3.969	21420	25200	0.06	SS 6301
	15	24	5	1.274	0.764	29070	34200	0.0074
28		7	3.567	2.117	26010	30600	0.016	SS 61902
32		9	4.586	2.695	24480	28800	0.03	SS 6002
35		11	6.370	3.577	21420	25200	0.045	SS 6202
42		13	9.369	5.096	18360	21600	0.085	SS 6302

* Bajo demanda se suministran diversas tipologías de diseños y medidas
* Available under request another stainless steel bearings solution

**RODAMIENTOS RÍGIDOS DE UNA HILERA DE BOLAS DE ACERO INOXIDABLE
RADIAL STAINLESS STEEL DEEP GROOVE BALL BEARINGS**



Dimensiones (mm) Dimension (mm)			Coeficiente de carga (KN) Load rating (KN)		Velocidad límite (rpm) Speed limit (Rpm)		Peso (Kg) Weight (Kg)	Sigla Designation
d (mm)	D (mm)	B (mm)	Dinámico Dynamic C	Estático Static C ₀	Lubricación Lubrication			
					Grasa Grease	Aceite Oil		
17	26	5	2.75	1.69	21420	25200	0.008	SS 61803
	30	7	3.822	2.401	21420	25200	0.018	SS 61903
	35	10	4.969	3.087	21420	25200	0.039	SS 6003
	40	12	7.899	4.557	18360	21600	0.065	SS 6203
	47	14	11.172	6.174	16830	19800	0.12	SS 6303
20	32	7	3.312	2.195	20160	25200	0.018	SS 61804
	37	9	6.27	3.63	16560	20700	0.036	SS 61904
	42	12	7.771	4.802	17280	21600	0.069	SS 6004
	47	14	10.584	6.272	14400	18000	0.11	SS 6204
	52	15	13.230	7.497	13680	17100	0.14	SS 6304
25	37	7	4.21	2.89	15120	18900	0.022	SS 61805
	42	9	5.802	4.067	15840	19800	0.045	SS 61905
	47	12	8.350	5.586	14400	18000	0.08	SS 6005
	52	15	11.662	7.497	12960	16200	0.13	SS 6205
	62	17	16.856	10.584	11520	14400	0.23	SS 6305
30	42	7	4.61	3.58	12960	16200	0.026	SS 61806
	47	9	7.11	4.9	12240	15300	0.048	SS 61906
	55	13	10.878	7.840	12240	15300	0.12	SS 6006
	62	16	15.974	10.584	10800	13500	0.2	SS 6206
	72	19	22.050	14.308	9360	11700	0.35	SS 6306
35	47	7	4.8	3.97	11520	14400	0.029	SS 61807
	55	10	10.98	7.31	10800	13500	0.74	SS 61907
	62	14	13.230	9.800	10800	13500	0.16	SS 6007
	72	17	21.168	14.308	9360	11700	0.29	SS 6207
	80	21	32.83	18.72	7200	9000	0.457	SS 6307
40	52	7	5	4.31	10080	12600	0.033	SS 61808
	62	12	14.31	10	9360	11700	0.11	SS 61908
	68	15	13.720	10.584	10080	12600	0.19	SS 6008
	80	18	24.206	16.954	7920	9900	0.37	SS 6208
	90	23	39.69	23.52	6624	8280	0.63	SS 6308
45	58	7	6.27	5.54	8640	10800	0.04	SS 61809
	68	12	15.1	11.2	8640	10800	0.128	SS 61909
	75	16	17.444	14.308	8640	10800	0.25	SS 6009
	85	19	27.048	19.208	7920	9900	0.41	SS 6209
	100	25	53	32	5904	7380	0.814	SS 6309
50	65	7	6.47	5.98	7920	9900	0.052	SS 61810
	72	12	15.29	11.96	7920	9900	0.132	SS 61910
	80	16	17.836	15.680	7920	9900	0.26	SS 6010
	90	20	29.008	21.952	7200	9000	0.46	SS 6210
	100	25	60.76	37.73	5400	6750	1.07	SS 6310

* Bajo demanda se suministran diversas tipologías de diseños y medidas
* Available under request another stainless steel bearings solution

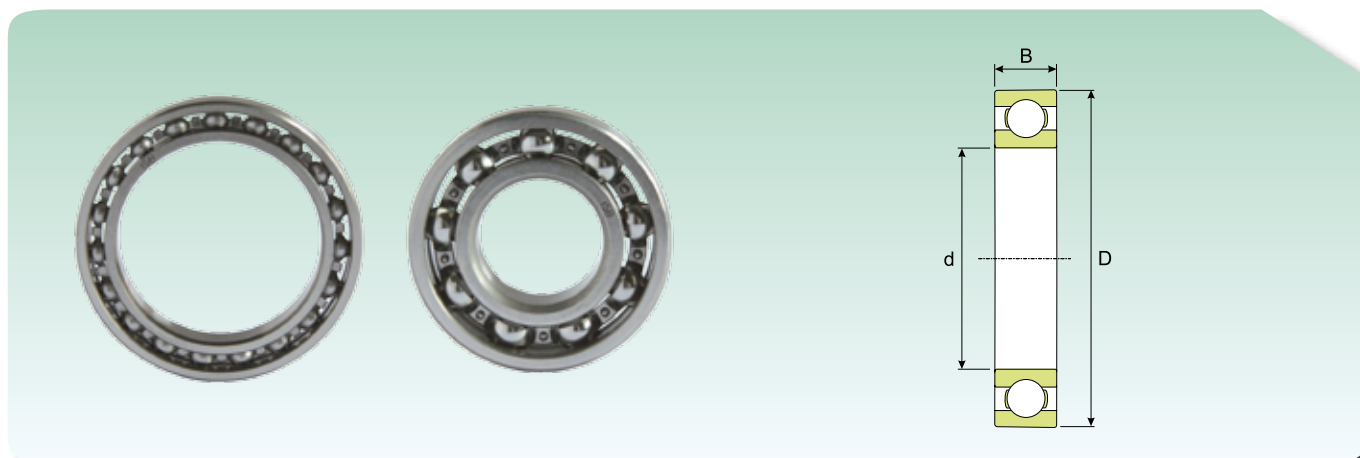
RODAMIENTOS RÍGIDOS DE UNA HILERA DE BOLAS DE ACERO INOXIDABLE RADIAL STAINLESS STEEL DEEP GROOVE BALL BEARINGS

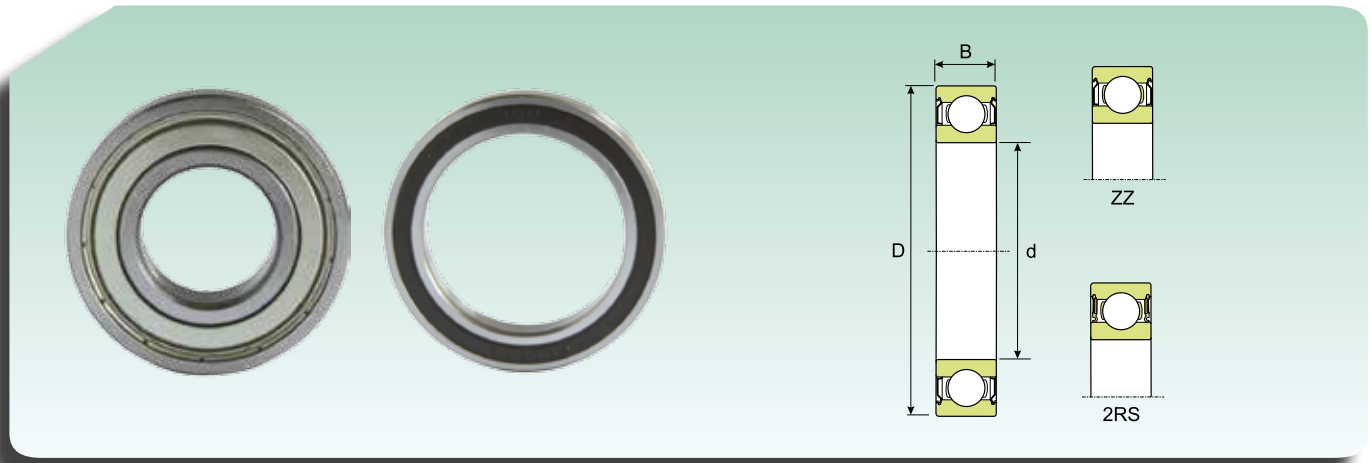

Dimensiones (mm) Dimension (mm)			Coeficiente de carga (KN) Load rating (KN)		Velocidad límite (rpm) Speed limit (Rpm)		Peso (Kg) Weight (Kg)	Sigla Designation
d (mm)	D (mm)	B (mm)	Dinámico Dynamic C	Estático Static C ₀	Lubricación Lubrication			
					Grasa Grease	Aceite Oil		
55	72	9	8.624	7.938	7200	9000	0.083	SS 61811
	80	13	15.68	13.034	6912	8640	0.18	SS 61911
	90	18	27.734	20.776	6480	8100	0.388	SS 6011
	100	21	42.63	28.616	5472	6840	0.601	SS 6211
	120	29	70.07	44.1	4896	6120	1.37	SS 6311
60	78	10	11.27	10.388	6768	8460	0.106	SS 61812
	85	13	16.072	14.014	6408	8010	0.193	SS 61912
	95	18	28.91	22.736	5976	7470	0.414	SS 6012
	110	22	51.45	35.28	5040	6300	0.783	SS 6212
65	85	10	11.368	10.78	6264	7830	0.128	SS 61813
	90	13	17.052	15.778	5904	7380	0.206	SS 61913
	100	18	29.89	24.696	5544	6930	0.421	SS 6013
	120	23	56.35	39.2	4680	5850	0.99	SS 6213
70	90	10	11.858	11.662	5832	7290	0.137	SS 61814
	100	16	23.226	20.776	5544	6930	0.334	SS 61914
	110	20	37.24	30.38	5112	6390	0.604	SS 6014
75	95	10	12.25	12.642	5472	6840	0.145	SS 61815
	105	16	23.912	22.148	5184	6480	0.353	SS 61915
80	100	10	12.446	13.034	5112	6390	0.154	SS 61816
	110	16	24.402	23.52	4824	6030	0.373	SS 61916

**RODAMIENTOS RÍGIDOS DE UNA HILERA DE BOLAS DE ACERO INOXIDABLE BLINDADOS
SEALED RADIAL STAINLESS STEEL DEEP GROOVE BALL BEARINGS**

Dimensiones (mm) Dimension (mm)			Coeficiente de carga (KN) Load rating (KN)		Velocidad límite* Speed limit*	Peso (Kg) Weight (Kg)	Sigla Designation
d (mm)	D (mm)	B (mm)	Dinámico Dynamic C	Estático Static C ₀			
1.5	4	2	0.112	0.033	104500	0.00014	SS 638/1.5-ZZ
2	5	2.3	0.153	0.047	90250	0.00018	SS 638/2-ZZ
	6	2.3	0.233	0.074	85500	0.00035	SS 619/2-ZZ
	6	3	0.233	0.074	85500	0.00035	SS 639/2-ZZ
3	6	3	0.212	0.083	76000	0.00035	SS 637/3-ZZ
	7	3	0.212	0.083	76000	0.00045	SS 638/3-ZZ
	8	3	0.382	0.126	71250	0.00067	SS 619/3-ZZ
	8	4	0.382	0.126	71250	0.0008	SS 639/3-ZZ
4	10	4	0.382	0.126	59850	0.0015	SS 623-ZZ
	9	3.5	0.440	0.170	66500	0.001	SS 628/4-ZZ
	9	4	0.440	0.170	66500	0.001	SS 638/4-ZZ
	11	4	0.593	0.220	59850	0.0017	SS 619/4-ZZ
	12	4	0.662	0.265	57000	0.0023	SS 604-ZZ
5	13	5	0.777	0.274	50350	0.0031	SS 624-ZZ
	13	5	0.777	0.274	30400	0.0031	SS 624-2RS
	16	5	0.905	0.358	45600	0.0054	SS 634-ZZ
	16	5	0.905	0.358	26600	0.005	SS 625-2RS
	19	6	1.823	0.897	38000	0.009	SS 635-ZZ
	19	6	1.823	0.897	38000	0.009	SS 625-2RS
6	10	3	0.313	0.134	57000	0.0007	SS 627/6-ZZ
	13	5	0.726	0.328	50350	0.0027	SS 628/6-ZZ
	15	5	1.019	0.446	47500	0.0037	SS 619/6-ZZ
	19	6	1.823	0.897	38000	0.0087	SS 626-ZZ
	19	6	1.823	0.897	22800	0.0087	SS 626-2RS
7	11	3	0.285	0.124	53200	0.0007	SS 627/7-ZZ
	14	5	0.790	0.382	47500	0.003	SS 628/7-ZZ
	17	5	1.215	0.529	42750	0.005	SS 619/7-ZZ
	19	6	1.823	0.897	40850	0.0082	SS 607-ZZ
	19	6	1.823	0.897	22800	0.0082	SS 607-2RS
	22	7	2.705	1.294	34200	0.013	SS 627-ZZ
8	16	5	1.098	0.539	42750	0.004	SS 628/8-ZZ
	16	6	1.098	0.539	42750	0.0043	SS 638/8-ZZ
	19	6	1.558	0.696	38000	0.0076	SS 619/8-ZZ
	22	7	2.705	1.294	36100	0.013	SS 608-ZZ
	22	7	2.705	1.294	20900	0.013	SS 608-2RS
9	17	5	1.166	0.608	40850	0.0044	SS 628/9-ZZ
	20	6	1.705	0.813	36100	0.0085	SS 619/9-ZZ
	24	7	3.058	1.568	32300	0.016	SS 609-ZZ
	26	8	3.822	1.862	28500	0.022	SS 629-ZZ

* Para los rodamientos blindados sólo de un lado son válidas las velocidades límite de los rodamientos abiertos
* For one side shield bearings speed limit, use the same value of open bearings

RODAMIENTOS RÍGIDOS DE UNA HILERA DE BOLAS DE ACERO INOXIDABLE BLINDADOS
SEALED RADIAL STAINLESS STEEL DEEP GROOVE BALL BEARINGS



Dimensiones (mm) Dimension (mm)			Coeficiente de carga (KN) Load rating (KN)		Velocidad límite* Speed limit*	Peso (Kg) Weight (Kg)	Sigla Designation
d (mm)	D (mm)	B (mm)	Dinámico Dynamic C	Estático Static C ₀			
10	19	5	1.117	0.559	36100	0.0056	SS 61800-ZZ
	19	5	1.117	0.559	20900	0.0056	SS 61800-2RS
	19	7	1.117	0.559	36100	0.0074	SS 63800-ZZ
	22	6	1.705	0.799	34200	0.01	SS 61900-ZZ
	26	8	3.822	1.862	32300	0.019	SS 6000-ZZ
	26	8	3.822	1.862	18050	0.019	SS 6000-2RS
	30	9	4.145	2.24	26600	0.032	SS 6200-ZZ
	30	9	4.145	2.24	16150	0.032	SS 6200-2RS
	35	11	6.625	3.19	24700	0.053	SS 6300-ZZ
35	11	6.625	3.19	14250	0.053	SS 6300-2RS	
12	21	5	1.19	0.63	34200	0.0065	SS 61801-ZZ
	24	6	1.87	0.94	30400	0.012	SS 61901-ZZ
	28	8	4.15	2.24	28500	0.022	SS 6001-ZZ
	28	8	4.15	2.25	16150	0.022	SS 6001-2RS
	32	10	5.74	2.94	14250	0.037	SS 6201-2RS
	32	10	5.74	2.94	24700	0.037	SS 6201-ZZ
	37	12	8.03	3.969	20900	0.06	SS 6301-ZZ
	37	12	8.03	3.969	13300	0.06	SS 6301-2RS
15	24	5	1.23	0.78	28500	0.0076	SS 61802-ZZ
	28	7	3.57	2.12	26600	0.019	SS 61902-ZZ
	28	7	4.38	2.26	-	0.019	SS 61902-2RS
	32	9	4.59	2.70	24700	0.03	SS 6002-ZZ
	32	9	5.86	2.86	-	0.03	SS 6002-2RS
	35	11	6.38	3.58	20900	0.045	SS 6202-ZZ
	35	11	6.38	3.58	12350	0.045	SS 6202-2RS
	42	13	9.37	5.10	18050	0.082	SS 6302-ZZ
	42	13	9.37	5.10	11400	0.082	SS 6302-2RS
17	26	5	2.75	1.69	32300	0.0082	SS 61803-ZZ
	26	5	2.75	1.69	32300	0.0082	SS 61803-2RS
	30	7	3.83	2.401	30400	0.019	SS 61903-ZZ
	35	10	4.97	3.11	20900	0.039	SS 6003-ZZ
	40	12	7.9	4.56	18050	0.065	SS 6203-ZZ
	47	14	11.18	6.18	16150	0.12	SS 6303-ZZ
	30	7	3.83	2.41	13300	0.019	SS 61903-2RS
	35	10	4.97	3.1	12350	0.039	SS 6003-2RS
	40	12	7.9	4.6	11400	0.065	SS 6203-2RS
	47	14	11.18	6.2	10450	0.12	SS 6303-2RS
	20	32	7	3.32	2.2	12350	0.018
37		9	5.29	3.5	11400	0.04	SS 61904-ZZ
37		9	5.29	3.5	11400	0.04	SS 61904-2RS
42		12	7.8	4.9	18050	0.069	SS 6004-ZZ
42		12	7.8	4.9	10450	0.069	SS 6004-2RS
47		14	10.6	6.3	16150	0.11	SS 6204-ZZ
47		14	10.6	6.3	9500	0.11	SS 6204-2RS
52		15	13.3	7.5	14250	0.14	SS 6304-ZZ
52		15	13.3	7.5	9025	0.14	SS 6304-2RS

* Para los rodamientos blindados sólo de un lado son válidas las velocidades límite de los rodamientos abiertos
 * For one side shield bearings speed limit, use the same value of open bearings

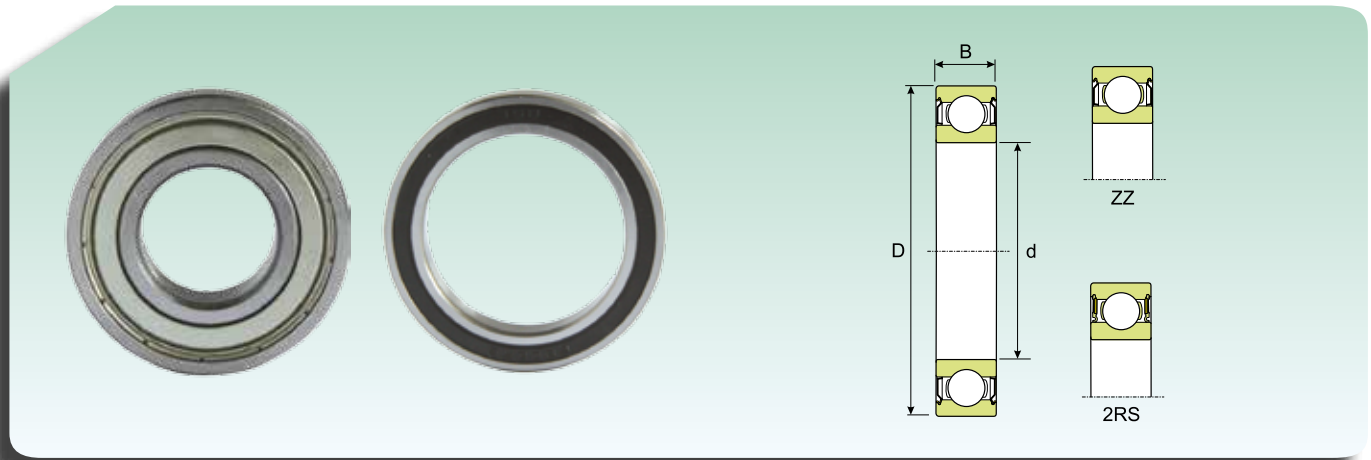
**RODAMIENTOS RÍGIDOS DE UNA HILERA DE BOLAS DE ACERO INOXIDABLE BLINDADOS
SEALED RADIAL STAINLESS STEEL DEEP GROOVE BALL BEARINGS**

Dimensiones (mm) Dimension (mm)			Coeficiente de carga (KN) Load rating (KN)		Velocidad límite* Speed limit*	Peso (Kg) Weight (Kg)	Sigla Designation
d (mm)	D (mm)	B (mm)	Dinámico Dynamic C	Estático Static C ₀			
25	37	7	4.6	3.58	10500	0.022	SS61805-ZZ
	37	7	4.6	3.58	10500	0.022	SS61805-2RS
	42	9	5.9	4.1	9500	0.047	SS 61905-2RS
	47	12	8.4	5.6	15200	0.08	SS 6005-ZZ
	47	12	8.4	5.6	9025	0.08	SS 6005-2RS
	52	15	11.7	7.5	13300	0.13	SS 6205-ZZ
	52	15	11.7	7.5	8075	0.13	SS 6205-2RS
	62	17	16.9	10.6	12350	0.23	SS 6305-ZZ
	62	17	16.9	10.6	7125	0.23	SS 6305-2RS
30	42	7	4.61	3.58	12960	0.026	SS 61806-ZZ
	42	7	4.61	3.58	12960	0.026	SS 61806-2RS
	47	9	7.11	4.9	12240	0.048	SS 61906-ZZ
	47	9	7.11	4.9	12240	0.048	SS 61906-2RS
	55	13	10.9	7.9	13300	0.12	SS 6006-ZZ
	55	13	10.9	7.9	7600	0.12	SS 6006-2RS
	62	16	16	10.6	11400	0.2	SS 6206-ZZ
	62	16	16	10.6	7125	0.2	SS 6206-2RS
	72	19	22.1	14.4	10450	0.35	SS 6306-ZZ
		72	19	22.1	5985	0.35	SS 6306-2RS
35	47	7	4.8	3.97	11520	0.029	SS 61807-ZZ
	47	7	4.8	3.97	11520	0.029	SS 61807-2RS
	55	10	10.98	7.31	10800	0.74	SS 61907-ZZ
	55	10	10.98	7.31	10800	0.74	SS 61907-2RS
	62	14	13.3	9.9	11400	0.16	SS 6007-ZZ
	62	14	13.3	9.9	6650	0.16	SS 6007-2RS
	72	17	21.2	14.4	9500	0.29	SS 6207-ZZ
	72	17	21.2	14.4	5985	0.29	SS 6207-2RS
	80	21	32.83	18.72	7200	0.457	SS 6307-ZZ
		80	21	32.83	18.72	7200	0.457
40	52	7	5	4.31	10080	0.033	SS 61808-ZZ
	52	7	5	4.31	10080	0.033	SS 61808-2RS
	62	12	14.31	10	9360	0.11	SS 61908-ZZ
	62	12	14.31	10	9360	0.11	SS 61908-2RS
	68	15	13.8	10.6	10450	0.19	SS 6008-ZZ
	68	15	13.8	10.6	5985	0.19	SS 6008-2RS
	80	18	24.3	17	8550	0.37	SS 6208-ZZ
	80	18	24.2	17	5320	0.37	SS 6208-2RS
	90	23	39.69	23.52	6624	0.63	SS 6308-ZZ
		90	23	39.69	23.52	6624	0.63
45	58	7	6.27	5.54	8640	0.04	SS 61809-ZZ
	58	7	6.27	5.54	8640	0.04	SS 61809-2RS
	68	12	15.1	11.2	8640	0.128	SS 61909-ZZ
	68	12	15.1	11.2	8640	0.128	SS 61909-2RS
	75	16	17.5	14.4	9500	0.25	SS 6009-ZZ
	75	16	17.5	14.4	5320	0.25	SS 6009-2RS
	85	19	27.1	19.3	8075	0.41	SS 6209-ZZ
		85	19	27.1	4750	0.41	SS 6209-2RS

* Para los rodamientos blindados sólo de un lado son válidas las velocidades límite de los rodamientos abiertos
* For one side shield bearings speed limit, use the same value of open bearings

RODAMIENTOS RÍGIDOS DE UNA HILERA DE BOLAS DE ACERO INOXIDABLE BLINDADOS
SEALED RADIAL STAINLESS STEEL DEEP GROOVE BALL BEARINGS



Dimensiones (mm) Dimension (mm)			Coeficiente de carga (KN) Load rating (KN)		Velocidad límite* Speed limit*	Peso (Kg) Weight (Kg)	Sigla Designation
d (mm)	D (mm)	B (mm)	Dinámico Dynamic C	Estático Static C ₀			
45	100	25	53	32	5904	0.814	SS 6309-ZZ
	100	25	53	32	5904	0.814	SS 6309-2RS
50	65	7	6.47	5.98	7920	0.052	SS 61810-ZZ
	65	7	6.47	5.98	7920	0.052	SS 61810-2RS
	72	12	15.29	11.96	7920	0.132	SS 61910-ZZ
	72	12	15.29	11.96	7920	0.132	SS 61910-2RS
	80	16	17.9	15.7	8550	0.26	SS 6010-ZZ
	80	16	17.9	15.7	4750	0.26	SS 6010-2RS
	90	20	29.1	22	7600	0.46	SS 6210-ZZ
	90	20	29.1	22	4560	0.46	SS 6210-2RS
	100	25	60.76	37.73	5400	1.07	SS 6310-ZZ
	100	25	60.76	37.73	5400	1.07	SS 6310-2RS
55	72	9	8.624	7.938	7200	0.083	SS 61811-ZZ
	72	9	8.624	7.938	7200	0.083	SS 61811-2RS
	80	13	15.68	13.034	6912	0.18	SS 61911-ZZ
	80	13	15.68	13.034	6912	0.18	SS 61911-2RS
	90	18	27.734	20.776	6480	0.388	SS 6011-ZZ
	90	18	27.734	20.776	6480	0.388	SS 6011-2RS
	100	21	42.63	28.616	5472	0.601	SS 6211-ZZ
	100	21	42.63	28.616	5472	0.601	SS 6211-2RS
	120	29	70.07	44.1	4896	1.37	SS 6311-ZZ
	120	29	70.07	44.1	4896	1.37	SS 6311-2RS
60	78	10	11.27	10.388	6768	0.106	SS 61812-ZZ
	78	10	11.27	10.388	6768	0.106	SS 61812-2RS
	85	13	16.072	14.014	6408	0.193	SS 61912-ZZ
	85	13	16.072	14.014	6408	0.193	SS 61912-2RS
	95	18	28.91	22.736	5976	0.414	SS 6012-ZZ
	95	18	28.91	22.736	5976	0.414	SS 6012-2RS
	110	22	51.45	35.28	5040	0.783	SS 6212-ZZ
	110	22	51.45	35.28	5040	0.783	SS 6212-2RS
65	85	10	11.368	10.78	6264	0.128	SS 61813-ZZ
	85	10	11.368	10.78	6264	0.128	SS 61813-2RS
	90	13	17.052	15.778	5904	0.206	SS 61913-ZZ
	90	13	17.052	15.778	5904	0.206	SS 61913-2RS
	100	18	29.89	24.696	5544	0.421	SS 6013-ZZ
	100	18	29.89	24.696	5544	0.421	SS 6013-2RS
	120	23	56.35	39.2	4680	0.99	SS 6213-ZZ
	120	23	56.35	39.2	4680	0.99	SS 6213-2RS
70	90	10	11.858	11.662	5832	0.137	SS 61814-ZZ
	90	10	11.858	11.662	5832	0.137	SS 61814-2RS
	100	16	23.226	20.776	5544	0.334	SS 61914-ZZ
	100	16	23.226	20.776	5544	0.334	SS 61914-2RS
	110	20	37.24	30.38	5112	0.604	SS 6014-ZZ
	110	20	37.24	30.38	5112	0.604	SS 6014-2RS

* Para los rodamientos blindados sólo de un lado son válidas las velocidades límite de los rodamientos abiertos
 * For one side shield bearings speed limit, use the same value of open bearings

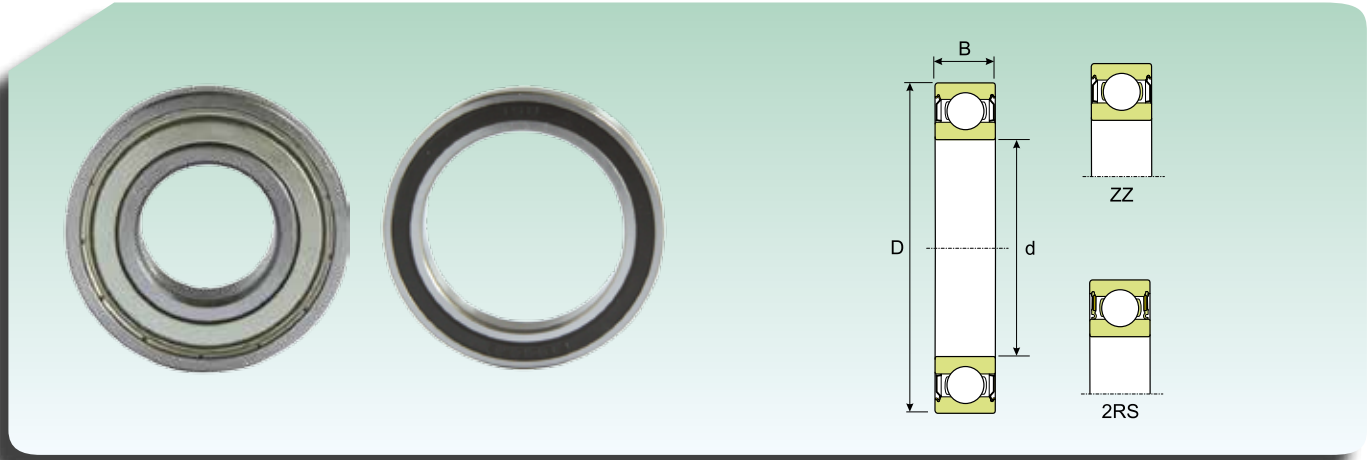
**RODAMIENTOS RÍGIDOS DE UNA HILERA DE BOLAS DE ACERO INOXIDABLE BLINDADOS
SEALED RADIAL STAINLESS STEEL DEEP GROOVE BALL BEARINGS**

Dimensiones (mm) Dimension (mm)			Coeficiente de carga (KN) Load rating (KN)		Velocidad límite* Speed limit*	Peso (Kg) Weight (Kg)	Sigla Designation
d (mm)	D (mm)	B (mm)	Dinámico Dynamic C	Estático Static C ₀			
75	95	10	12.25	12.642	5472	0.145	SS 61815-ZZ
	95	10	12.25	12.642	5472	0.145	SS 61815-2RS
	105	16	23.912	22.148	5184	0.353	SS 61915-ZZ
	105	16	23.912	22.148	5184	0.353	SS 61915-2RS
80	100	10	12.446	13.034	5112	0.154	SS 61816-ZZ
	100	10	12.446	13.034	5112	0.154	SS 61816-2RS
	110	16	24.402	23.52	4824	0.373	SS 61916-ZZ
	110	16	24.402	23.52	4824	0.373	SS 61916-2RS

* Para los rodamientos blindados sólo de un lado son válidas las velocidades límite de los rodamientos abiertos
* For one side shield bearings speed limit, use the same value of open bearings



Rodamientos rígidos de dos hileras de bolas

Radial deep groove ball bearings, double rows



RODAMIENTOS RÍGIDOS DE DOS HILERAS DE BOLAS

Los rodamientos **ISB**[®] rígidos de dos hileras de bolas (**Fig. 1**) logran resistir cargas axiales en los dos sentidos sumadas a las cargas radiales, ya que cuentan con ranuras profundas y con un elevado grado de contacto entre las bolas y los caminos de rodadura. Este tipo de rodamiento está indicado para aplicaciones en las cuales la capacidad de carga de los rodamientos de una bola no es suficiente; en efecto con el mismo diámetro externo y con el mismo agujero, los rodamientos de dos hileras de bolas soportan cargas muy superiores respecto a los de una sola hilera de bolas

DOUBLE ROW DEEP GROOVE RADIAL BALL BEARINGS

(**Fig. 1**) Due to the fact that the double row deep groove radial ball bearings produced by **ISB**[®] have deep grooves and very close conformity between balls and raceways, they are able to withstand axial loads in both directions in addition to radial loads. This type of bearing is suitable for applications in which the load carrying capacity of single row bearings is inadequate; with the same outside diameter and bore, double row ball bearings do indeed withstand much higher loads than single row bearings.

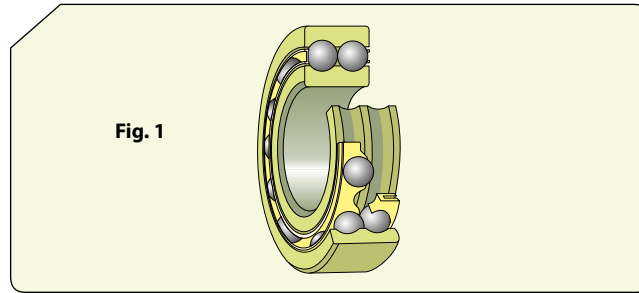

DIMENSIONES

Las dimensiones generales de los rodamientos **ISB**[®] rígidos de dos hileras de bolas respetan la norma ISO 15:1998.

TOLERANCIA

Los rodamientos **ISB**[®] rígidos de dos hileras de bolas se fabrican según las tolerancias normales.

JUEGO INTERNO

Los rodamientos **ISB**[®] rígidos de dos hileras de bolas se fabrican con un juego interno Normal, de conformidad con la norma 57-53:1991.

DESALINEACIÓN

Cada desalineación de los aros del rodamiento causa una disminución de silenciosidad.

JAULAS

Los rodamientos **ISB**[®] rígidos de dos hileras de bolas prevén dos jaulas moldeadas por inyección, a presión, en poliamida 6.6 reforzada en fibra de vidrio y centradas en las bolas (**Fig. 2**) sufijo TN9 en la sigla.

Este tipo de rodamiento puede utilizarse a temperaturas que alcanza los +120°C, los lubricantes utilizados generalmente no dañan las jaulas.

DIMENSIONS

The overall dimensions of **ISB**[®] double row deep groove radial ball bearings comply with standard ISO 15:1998.

TOLERANCE

ISB[®] double row deep groove radial ball bearings are manufactured pursuant to Normal tolerances.

INTERNAL CLEARANCE

ISB[®] double row deep groove radial ball bearings are manufactured with Normal internal radial clearance, pursuant to standard ISO 57-53:1991.

MISALIGNMENT

Misalignment in the rings of the bearing will result in higher noise of the bearing.

CAGES

ISB[®] double row deep groove radial ball bearings are fitted with two injection moulded snap-type cages of polyamide 6.6 with fibreglass reinforcement and centred on the balls (**Fig. 2**), with designation suffix TN9.

This type of bearing can be used at temperatures up to +120°C. The lubricants used do not usually have a detrimental effect on the cages.

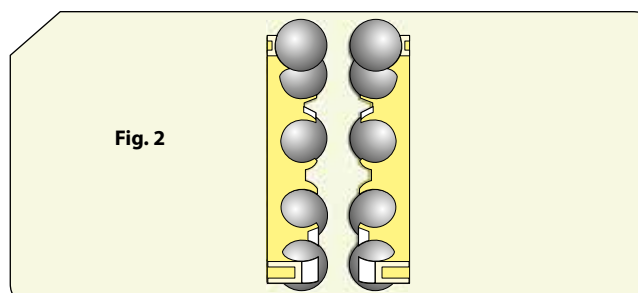

CARGA MÍNIMA

Necesaria para garantizar un funcionamiento correcto. Todos los rodamientos deben estar sujetos a una cierta carga mínima. En los casos en que exista rotación a altas velocidades, aceleraciones elevadas o repentinos cambios de dirección, las fuerzas de inercia de las bolas y de las jaulas, la fricción del lubricante, influyen negativamente sobre las condiciones del sistema rodamiento, provocando deslizamientos perjudiciales entre las bolas y los caminos de rodadura.

CAPACIDAD DE CARGA AXIAL

Si los rodamientos **ISB**® rígidos de bolas de acero se someten a una carga axial, ésta no debe superar un valor de 0.5 C₀. Cargas superiores pueden causar reducción de la vida del rodamiento.

MINIMUM LOAD

This is required to guarantee efficient operation. All rolling bearings must be subjected to a certain minimum load. If they are to operate at high rotation speeds, high accelerations or sudden changes in direction, the inertia forces of the balls and of the cages and the friction of the lubricant have a detrimental effect on the conditions of the bearing arrangement and may cause harmful contact between the balls and the raceways.

AXIAL LOAD CARRYING CAPACITY

*If **ISB**® deep groove steel ball bearings are subjected to an axial load, the latter must not exceed a value of 0.5 C₀. Greater loads may reduce the bearing life span.*

**RODAMIENTOS RÍGIDOS DE DOS HILERAS DE BOLAS
RADIAL DEEP GROOVE BALL BEARINGS - DOUBLE ROW**

Dimensiones (mm) Dimension (mm)			Coeficiente de carga (KN) Load rating (KN)		Velocidad límite (rpm) Speed limit (Rpm)		Peso (Kg) Weight (Kg)	Sigla Designation
d (mm)	D (mm)	B (mm)	Dinámico C	Estático C ₀	Lubricación Lubrication			
					Grasa Grease	Aceite Oil		
10	30	14	9.05	5.10	16830	19800	0.049	4200 ATN9
12	32	14	10.39	6.08	15300	18000	0.053	4201 ATN9
	37	17	12.74	7.64	13770	16200	0.092	4301 ATN9
15	35	14	11.66	7.35	13005	15300	0.059	4202 ATN9
	42	17	14.50	9.31	11475	13500	0.12	4302 ATN9
17	40	16	14.50	9.31	11475	13500	0.09	4203 ATN9
	47	19	19.11	12.94	9945	11700	0.16	4303 ATN9
20	47	18	17.44	12.25	9945	11700	0.14	4204 ATN9
	52	21	22.93	15.68	9180	10800	0.21	4304 ATN9
25	52	18	18.62	14.31	8415	9900	0.16	4205 ATN9
	62	24	31.26	21.95	7650	9000	0.34	4305 ATN9
30	62	20	25.48	20.38	7268	8550	0.26	4206 ATN9
	72	27	40.18	29.40	6503	7650	0.5	4306 ATN9
35	72	23	34.40	27.93	6120	7200	0.4	4207 ATN9
	80	31	49.69	37.24	5738	6750	0.69	4307 ATN9
40	80	23	36.36	31.85	5355	6300	0.5	4208 ATN9
	90	33	54.78	44.10	5126	6030	0.95	4308 ATN9
45	85	23	38.22	35.28	5126	6030	0.54	4209 ATN9
	100	36	67.52	54.88	4590	5400	1.25	4309 ATN9
50	90	23	40.18	39.20	4590	5400	0.58	4210 ATN9
	110	40	80.26	68.11	4055	4770	1.7	4310 ATN9
55	100	25	44.00	43.12	4284	5040	0.8	4211 ATN9
	120	43	95.55	81.34	3825	4500	2.15	4311 ATN9
60	110	28	56.06	53.90	4055	4770	1.1	4212 ATN9
	130	46	109.76	96.04	3443	4050	2.65	4312 ATN9
65	120	31	66.25	65.66	3672	4320	1.45	4213 ATN9
	140	48	118.58	103.88	3290	3870	3.25	4313 ATN9
70	125	31	68.80	72.03	3290	3870	1.5	4214 ATN9
	150	51	135.24	122.50	2907	3420	3.95	4314 ATN9
75	130	31	71.34	78.40	3060	3600	1.6	4215 ATN9
	160	55	152.88	140.14	2754	3240	4.8	4315 ATN9
80	140	33	78.99	88.20	2907	3420	2	4216 ATN9
85	150	36	91.73	99.96	2754	3240	2.55	4217 ATN9
90	160	40	109.76	119.56	2601	3060	3.2	4218 ATN9
100	180	46	137.20	152.88	2295	2700	4.7	4220 ATN9



Rodamientos de bolas de contacto angular

Angular contact ball bearings

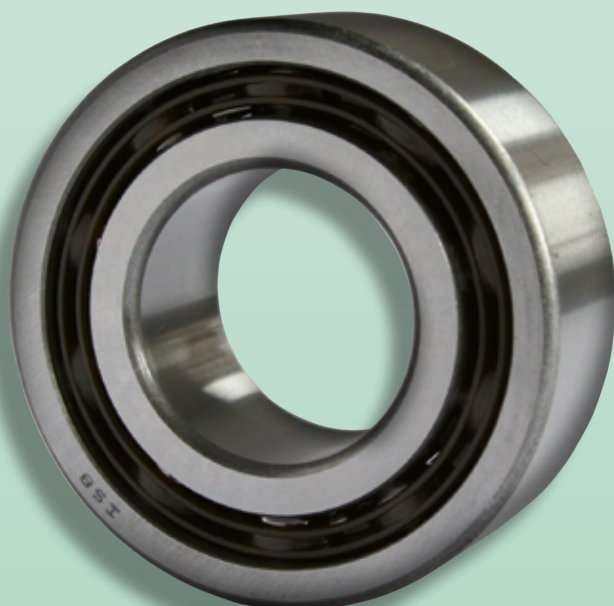
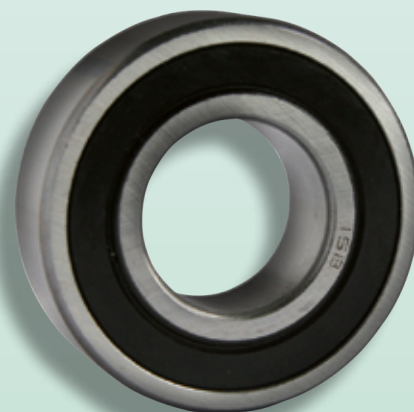
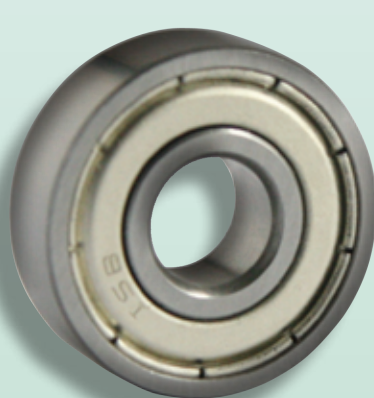

RODAMIENTOS DE BOLAS CON CONTACTO ANGULAR

Los rodamientos **ISB**[®] de bolas con contacto angular son idóneos para soportar cargas que actúan tanto en sentido radial como también axial, aumentando su capacidad de soportar dichas cargas combinadas en modo proporcional al aumento del ángulo de contacto. Esta característica se debe a la posición de los caminos de rodadura de los aros interiores y exteriores.

ISB[®] produce los rodamientos de bolas con contacto angular en una amplia variedad de configuraciones, las más comunes son:

- Rodamientos **ISB**[®] de una hilera de bolas con contacto angular (**Fig. 1**);

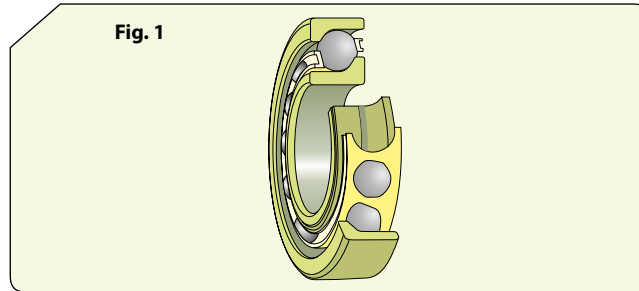

- Rodamientos **ISB**[®] de dos hileras de bolas con contacto angular (**Fig. 2**);

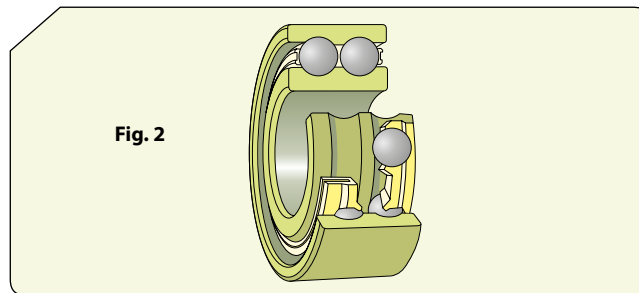

Para completar la descripción de los rodamientos **ISB**[®] de bolas con contacto angular se expone a continuación la definición de ángulo de contacto.

Se denomina ángulo de contacto al ángulo entre la línea que alcanza los puntos de contacto entre las bolas y los caminos de rodadura en el plano radial, a lo largo de la cual la carga se transmite de un camino de rodadura a otro, y una línea perpendicular al eje del rodamiento.

ANGULAR CONTACT BALL BEARINGS

ISB[®] angular contact ball bearings are able to withstand loads that act both radially and axially. Their load carrying capacity of such combined loads increases proportionally as the contact angle increases. This feature is due to the position of the raceways of the inner and outer rings.

ISB[®] produces angular contact ball bearings in a wide range of configurations. The most commonly used ones are the following:

- **ISB**[®] single row angular contact ball bearings (**Fig. 1**);

- **ISB**[®] double row angular contact ball bearings (**Fig. 2**);

To complete the description of **ISB**[®] angular contact ball bearings, the definition of the contact angle is indicated.

By contact angle, we mean the angle between the line that joins the points of contact between the balls and the raceways on the radial plane, along which the load is transmitted from one raceway to another, and a line that is perpendicular to the bearing axis.

RODAMIENTOS DE UNA HILERA DE BOLAS CON CONTACTO ANGULAR

Generalmente el rodamiento suele ajustarse contra un segundo rodamiento, ya que pueden soportar cargas axiales que actúan en un solo sentido. Este tipo de rodamientos puede soportar una carga axial muy elevada, ya que su ángulo de contacto es de 40° (**Fig. 1**).

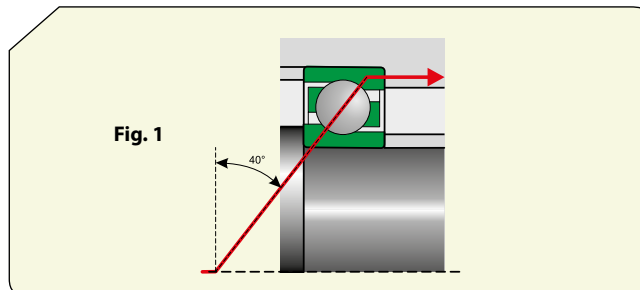

SINGLE ROW ANGULAR CONTACT BALL BEARINGS

They are normally fitted against a second bearing, because they can withstand axial loads that act just in one direction. These types of bearings can withstand a very high axial load because their contact angle is equal to 40° (**Fig. 1**).

Dentro de la variedad de rodamientos **ISB**® de una hilera de bolas con contacto angular están comprendidas las series 72B y 73B. Están previstas dos versiones, para igual número de aplicaciones:

- Rodamientos con diseño básico: empleados únicamente para disposiciones con rodamientos individuales.
- Rodamientos para montaje universal: pueden ser montados según las disposiciones expuestas en la **Fig. 2**. Para estas aplicaciones solicitar informaciones a nuestra oficina técnica.

Otras características importantes de los rodamientos **ISB**® de una hilera de bolas con contacto angular:

- son monobloque
- los aros tienen un apoyo superior y uno inferior.

Esta última configuración permite incorporar un gran número de bolas, garantizando capacidades de carga elevadas para el rodamiento.

RODAMIENTOS CON DISEÑO BÁSICO

Concebidos para un montaje individual y no directamente adyacentes entre sí, se ensamblan con clase de precisión Normal, en cuanto a la anchura y el stand out de los aros.

RODAMIENTOS PARA MONTAJE UNIVERSAL

Los rodamientos **ISB**® de una hilera de bolas con contacto angular pueden montarse emparejados (por pares). Están previstos tres tipos de acoplamientos

- Disposición en tándem (**Fig. 2a**). Utilizada cuando la capacidad de carga del rodamiento individual no resulta suficiente. Las líneas de acción son paralelas entre sí, las cargas radiales y axiales se disponen uniformemente entre los dos rodamientos. Generalmente se monta en sentido opuesto respecto a la pareja de rodamientos un tercer rodamiento, que sirve para soportar la carga axial orientada en sentido opuesto, porque la pareja resiste sólo las cargas axiales que se dirigen en un solo sentido. Al realizar el pedido contactar nuestra oficina técnica.
- Disposición espalda con espalda (**Fig. 2a**). Se emplea este tipo de montaje cuando se deben soportar cargas axiales en los dos sentidos. Las líneas de acción divergen hacia el eje de los rodamientos. La carga axial está soportada en los dos sentidos, pero sólo por un rodamiento a la vez, la aplicación

The range of **ISB**® single row angular contact ball bearings includes series 72B and 73B. They are produced in two versions for just as many different applications:

- *Basic design bearings: used just for arrangements with single bearings.*
- *Bearings for Universal matching: they can be fitted according to the arrangements as per **Fig. 2**. Please contact our engineering department for information on these applications.*

Other special features of **ISB**® single row angular contact ball bearings are:

- They are one single self-contained piece.
- The rings have a top shoulder and a bottom shoulder.

This last feature means that they can incorporate a large number of balls to guarantee the high load carrying capacity of the bearing.

BASIC DESIGN BEARINGS

They are designed for arrangements where only one bearing is used and not one next to the other. Their assembly class of precision is Normal, in terms of the width and stand out of the rings.

BEARINGS FOR UNIVERSAL MATCHING

ISB® single row angular contact ball bearings can be fitted in pairs. There are three types of possible matches:

- *Tandem arrangement (**Fig. 2a**). Used when the load carrying capacity of a single bearing is inadequate. The load lines are parallel and the radial and axial loads are equally distributed between the two bearings. A third bearing is usually fitted against the tandem arrangement that takes the axial load directed in the opposite direction because the pair only withstands axial loads directed in just one direction. Please contact our engineering department before placing any orders.*
- *Back-to-back arrangement (**Fig. 2b**). This type of assembly is used when axial loads need to be borne in both directions. The load lines diverge towards the axis of the bearings. The axial load is borne in both directions but only by one bearing at a time, and the application is stiff. The back-to-*

resulta rígida. La disposición espalda con espalda es adecuada también para soportar pares de vuelco. Al realizar el pedido contactar nuestra oficina técnica.

- Disposición cara a cara (**Fig. 2c**). Se emplea este tipo de montaje cuando se deben soportar cargas axiales en los dos sentidos. Las líneas de contacto convergen hacia el eje del rodamiento. También en este caso la carga axial se soporta en ambos sentidos, siempre por un solo rodamiento a la vez. Este tipo de disposición resulta menos rígida que la anterior, pero también menos idónea para soportar pares de vuelco. Al realizar el pedido contactar nuestra oficina técnica.

back type arrangement can also react to tilting motions. Please contact our engineering department before placing any orders.

- *Face-to-face arrangement (**Fig. 2c**). Used when axial loads need to be borne in both directions. The contact lines converge towards the bearing axis. In this case again, the axial load is borne in both directions, always and only by one bearing at a time. This type of arrangement is not as stiff as the back-to-back arrangement but is less suitable for tilting motions. Please contact our engineering department before placing any orders.*

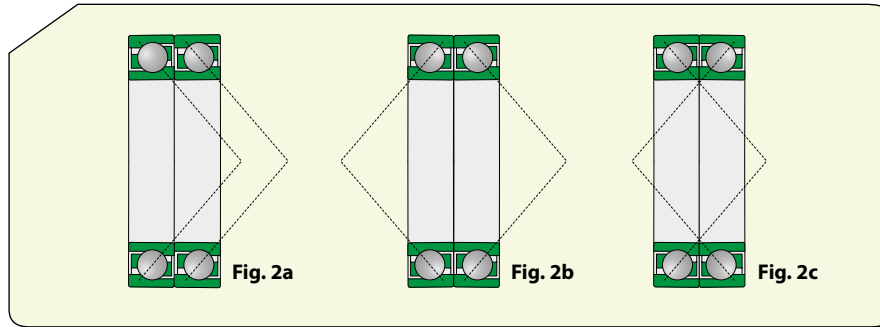

RODAMIENTOS DE DOS HILERAS DE BOLAS CON CONTACTO ANGULAR

Las principales características de los rodamientos **ISB**® de dos hileras de bolas con contacto angular permiten soportar cargas radiales y axiales que actúan en ambos sentidos, soportar pares de vuelco y realizar aplicaciones rígidas.

La peculiaridad principal de este tipo de rodamiento es la de ser equivalente a dos rodamientos **ISB**® de una hilera de bolas con contacto angular adyacentes, con la única diferencia de ocupar menos espacio en sentido axial.

La gama de rodamientos **ISB**® de dos hileras de bolas con contacto angular está compuesta por:

- Rodamientos de diseño estándar (**Fig. 1a**);
- Rodamientos blindados (**Fig. 1b**);
- Rodamientos con aro interior en dos partes (**Fig. 1c**).

DOUBLE ROW ANGULAR CONTACT BALL BEARINGS

*The main characteristics of **ISB**® double row angular contact ball bearings are that they withstand radial and axial loads acting in both directions and tilting motions and that they can be used for stiff applications.*

*The main peculiarity of this type of bearing is that it is equivalent to two **ISB**® single row angular contact ball bearings set side-by-side with the only difference being that it occupies less axial space.*

*The range of **ISB**® double row angular contact ball bearings comprises:*

- *Standard bearings (**Fig. 1a**);*
- *Shielded bearings (**Fig. 1b**);*
- *Bearings with inner ring in two pieces (**Fig. 1c**)*

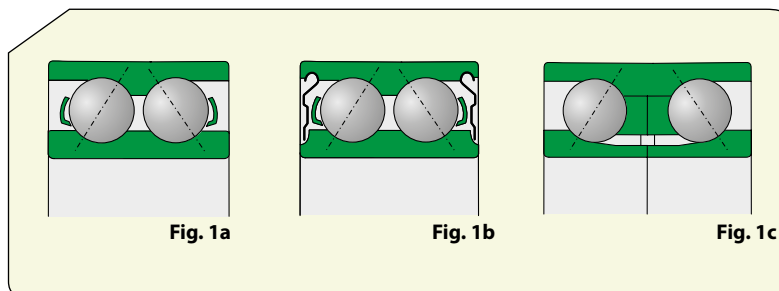

RODAMIENTOS CON DISEÑO BÁSICO

Ángulo de contacto 30°, grupos de bolas dispuestos espalda con espalda. Los rodamientos **ISB**® de dos hileras de bolas con contacto angular de las series 32 y 33 presentan numerosas ventajas, debidas a la geometría interior optimizada que los caracteriza y a la ausencia de ranurados para la introducción de las bolas. Estos rodamientos ofrecen la ventaja de poder aplicarse en modo universal, de soportar elevadas cargas, tanto axiales como también radiales y, por último, de ser mucho más silenciosos. **ISB**® los ofrece también con obturaciones, blindajes y con ranuras para las obturaciones en los aros interior y exterior (**Fig. 2**).

BASIC DESIGN BEARINGS

They have a contact angle of 30° and the sets of balls are arranged back-to-back. **ISB**® double row angular contact ball bearings of series 32 and 33 offer various advantages in view of their optimised internal design and the lack of filling slots. These bearings offer the benefit of being universally applicable, of withstanding high axial and radial loads and finally of being very quiet. **ISB**® also supplies them with seal rings, shields and with grooves for the seals on the inner and outer rings (**Fig. 2**).

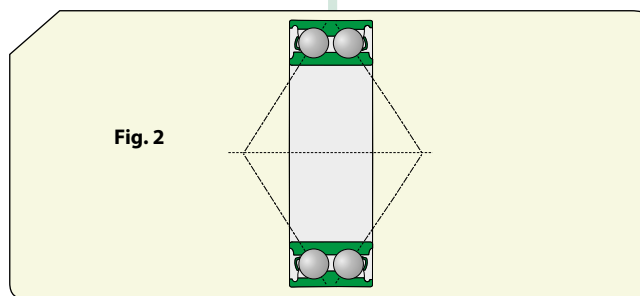

RODAMIENTOS BLINDADOS

Presentan el sufijo ZZ y han sido diseñados para ser utilizados en los casos en los cuales el aro interior gire (**Fig. 3**).

Si se verifica eventualmente la rotación del aro exterior a altas velocidades se puede producir una leve pérdida de grasa del rodamiento. No lavarlos nunca ni calentarlos a temperaturas de más de 80°.

SHIELDED BEARINGS

Their suffix is ZZ and they are designed to be used if the inner ring rotates (**Fig. 3**).

If the outer ring rotates at high speed, a slight amount of grease could leak from the bearing. They must not be washed or heated to temperatures beyond 80°.

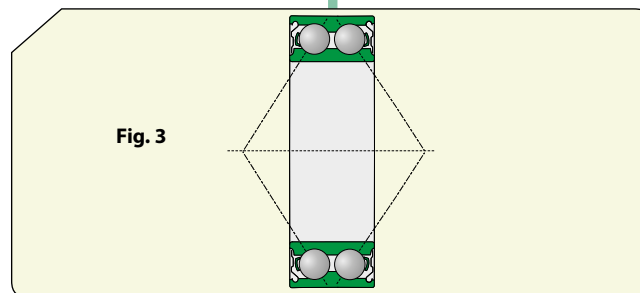

RODAMIENTOS CON OBTURACIONES

El intervalo de las temperaturas a las cuales se aconseja su utilización va de -40° a +100° C con un pico máximo, en caso de breves períodos, de +120°. Llevan el sufijo 2RS, están compuestos por obturaciones de goma acrilonitrilo-butadieno, reforzadas con chapas de acero montado en la zona de las gargantas presentes en el aro interior (**Fig. 4**). Si se alcanzan velocidades y temperaturas elevadas se pueden verificar pérdidas de grasa en la zona del aro interior.

SEALED BEARINGS

The recommended operating temperature range is from -40° to +100° C with maximum peak of +120° for short periods. Their suffix is 2RS, and they have Nitrile-Butadiene-Rubber seals with sheet steel reinforcement fitted against the grooves in the inner ring (**Fig. 4**). Slight amounts of grease could leak from the inner ring under high operating speeds and temperatures.

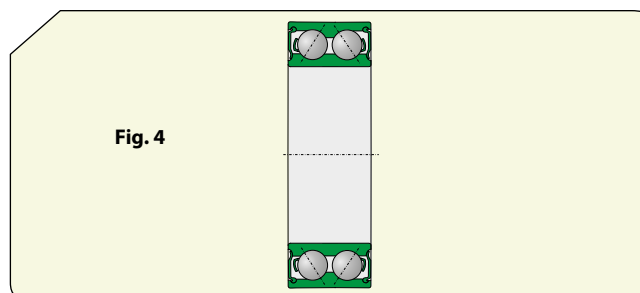

RODAMIENTOS CON ARO INTERIOR EN DOS PARTES

Esta es la tercera y última versión en la que pueden ser suministrados los rodamientos ISB de dos hileras de bolas con contacto angular. Los rodamientos de la gama 33 D son capaces de resistir a cargas axiales muy elevadas, este tipo específico de rodamiento cuenta con un elevado número de bolas, un ángulo de contacto de 45° y un juego interior especial. Otra característica es la de ser desarmable, esto significa que el aro exterior con las bolas y la jaula se pueden desmontar por separado de las dos mitades del aro interior (**Fig. 5**).

BEARINGS WITH INNER RING IN TWO PIECES

This is the third and last version in which the **ISB**® double row angular contact ball bearings can be supplied. The bearings of the 33 D range can withstand very high axial loads. This specific kind of bearing has a large number of balls, a contact angle of 45° and special internal clearance. Another special feature is that it is separable, meaning that the outer ring with balls and cage can be fitted separately from the two halves of the inner ring (**Fig. 5**).

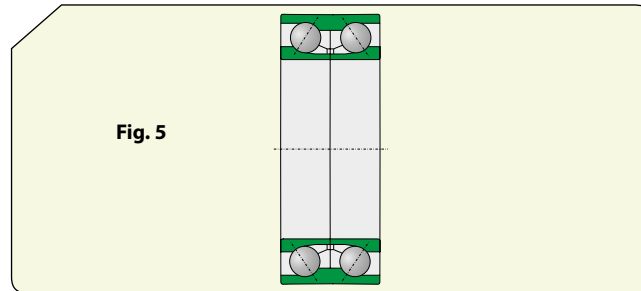

DIMENSIONES

Las dimensiones generales de los rodamientos **ISB**® de dos hileras de bolas con contacto angular respetan la norma ISO 15:1998.

TOLERANCIAS

Los rodamientos **ISB**® de dos hileras de bolas con contacto angular se fabrican en la clase de precisión normal.

JUEGO INTERNO Y PRE-CARGA

Se logra sólo con el rodamiento montado y depende del ajuste que se adopta, en base al segundo rodamiento, determinando de este modo la posición axial en sentido opuesto.

Para las series 32 y 33, se ofrecen dos tipos de juego interior, el normal y el sobredimensionado C3.

DESALINEACIÓN

La desalineación soportada por los rodamientos **ISB**® de una hilera de bolas con contacto angular es muy reducida. Estando definida por una relación muy compleja entre el juego dentro del rodamiento durante el servicio, el tamaño, la configuración interior del rodamiento y las fuerzas que actúan sobre el mismo, no resulta posible indicar valores específicos generalizables.

Para los rodamientos **ISB**® de una hilera de bolas con contacto angular con montaje por parejas, en especial para aquellos con disposición espalda con espalda, la desalineación puede ser soportada sólo si se aumentan las cargas en las bolas. Esto provoca notables tensiones en la jaula e implica, por lo tanto, una reducción de la vida del rodamiento. Otra consecuencia de la desalineación de los aros del rodamiento **ISB**® de una hilera de bolas con contacto angular es la reducción de la silenciosidad en el servicio.

Para los rodamientos **ISB**® de dos hileras de bolas con contacto angular las fuerzas que se generan entre las bolas y los caminos de rodadura compensan la desalineación que se crea entre aros interiores y exteriores. Dicho problema se refleja en la silenciosidad del producto y en su durabilidad.

DIMENSIONS

The overall dimensions of **ISB**® single and double row angular contact ball bearings comply with standard ISO 15:1998.

TOLERANCES

ISB® standard single and double row angular contact ball bearings are produced in the Normal class of precision.

INTERNAL CLEARANCE AND PRELOAD

This is only obtained after fitting the bearing and depends on the adjustment adopted based on the second bearing, which thus establishes the axial position in the opposite direction.

For series 32 and 33, there are two types of internal clearance: normal and up-rated C3.

MISALIGNMENT

ISB® standard single row angular contact ball bearings only accepts a very limited misalignment (a few arc minutes). Seeing as it is defined by a rather complex relationship between the internal clearance of the bearing during operation, the dimensions, the internal configuration of the bearing and the forces that act on it, it is impossible to indicate any specific universally valid values.

For **ISB**® single row angular contact ball bearings mounted in pairs, especially in back-to-back arrangement, the misalignment is only tolerated if the loads on the balls increase. This causes considerable strain on the cage and consequently implies a reduction in the bearing's life span. Another consequence of misalignment of the rings of **ISB**® single row angular contact ball bearings will be increased noise during operation.

For the **ISB**® double row angular contact ball bearings, the force generated between the balls and the raceways compensate the misalignment between the inner and outer rings. This problem affects the level of noise of the product and its life.

JAULAS

A continuación se enumeran las jaulas estándar de los rodamientos **ISB**® de una hilera de bolas con contacto angular:

- Jaula moldeada por inyección, de tipo ventana, centrada en las bolas, en poliamida 6.6 reforzada en fibra de vidrio (**Fig. 6a**)
- Jaula estampada de latón, de tipo-ventana, centrada en las bolas con el sufijo Y (**Fig. 6b**).
- Jaula mecanizada de latón, de tipo-ventana, centrada en las bolas con el sufijo M (**Fig. 6c**).

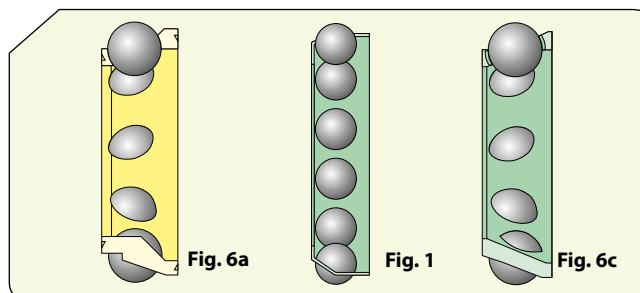

CAGES

Here's a list of the cages supplied standard with **ISB**® single row angular contact ball bearings:

- Injection moulded window-type cage, centred on the balls, made of polyamide 6.6 with fibreglass reinforcement (**Fig. 6a**).
- Pressed window-type brass cage, centred on the balls, with designation suffix Y (**Fig. 6b**).
- Solid machined window-type brass cage, centred on the balls, with designation suffix M (**Fig. 6c**).

Existen 3 tipos de jaulas para los rodamientos **ISB**® de dos hileras de bolas con contacto angular:

- Jaula moldeada por inyección, en poliamida 6.6 reforzada con fibra de vidrio, resistentes a temperaturas de utilización de hasta +120°, con el sufijo TN9 (**Fig. 7a**);
- Jaula de acero, sin sufijo en el nombre (**Fig. 7b**);
- Jaula mecanizada de latón, centrada en el aro externo, MA el sufijo en el nombre (**Fig. 7c**).

There are three types of cages for **ISB**® double row angular contact ball bearings:

- Injection moulded cage made of polyamide 6.6 with fibre-glass reinforcement, resistant to working temperatures up to +120°C, with designation suffix TN9 (**Fig. 7a**).
- Pressed steel cage, without any designation suffix (**Fig. 7b**).
- Solid machined brass cage centered on the outer ring with designation suffix MA (**Fig. 7c**).

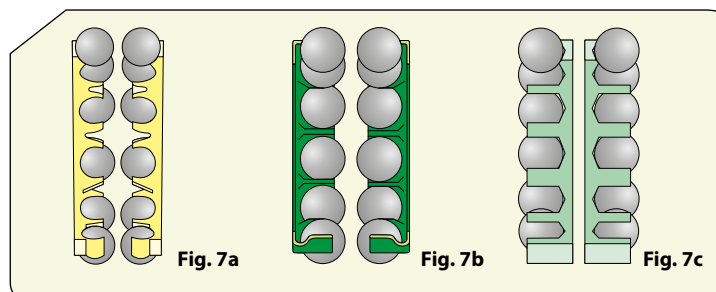

VELOCIDADES PARA PAREJAS DE RODAMIENTOS

Para rodamientos montados en parejas, reducir del 20% los valores expuestos en la tabla productos.

SPEED RATINGS FOR PAIRED BEARINGS

For paired bearings, the values indicated in the product table are 20% lower.

DESIGNACIONES SUPLEMENTARIAS

Estas designaciones suplementarias son necesarias para poder reconocer fácilmente algunas de las características:

SUPPLEMENTARY DESIGNATIONS

These designations are required to easily recognise some characteristics:

A	Sin ranura de llenado
B	Ángulo de contacto 40°
C2	Juego axial interior inferior normal
C3	Juego axial interior superior normal
D	Aro interno en dos partes
M	Jaula mecanizada de latón, de tipo-ventana, centrada en las bolas
P5	Precisión dimensional y de rotación según la clase de tolerancia 5 de la norma ISO
P6	Precisión dimensional y funcionamiento de conformidad con la clase de tolerancia 6 de la norma ISO
2RS	Obturación rozante de acrílonitrilo-butadieno reforzadas con chapa de acero en ambos lados del rodamiento
TN9	Jaula moldeada por inyección, de montaje a presión en poliamida 6.6 reforzada con fibras de vidrio centrada en las bolas
ZZ	Blindaje de chapa de acero en ambos lados del rodamiento

A	<i>No filling slots</i>
B	<i>Contact angle 40°</i>
C2	<i>Internal axial clearance smaller than normal</i>
C3	<i>Internal axial clearance greater than normal</i>
D	<i>Two-piece inner ring</i>
M	<i>Solid machined window-type brass cage, centred on the balls</i>
P5	<i>Dimensional and rotation precision pursuant to tolerance class 5 of ISO standard</i>
P6	<i>Dimensional and rotation precision pursuant to tolerance class 6 of ISO standard</i>
2RS	<i>Nitrile-Butadiene-Rubber (NBR) contact seal with pressed sheet steel reinforcement, on both sides of the bearing</i>
TN9	<i>Injection moulded snap-type cage made of polyamide 6.6 with fibreglass reinforcement, centred on the balls</i>
ZZ	<i>Shield made of pressed sheet steel on both sides of the bearing</i>

RODAMIENTOS DE UNA HILERA DE BOLAS CON CONTACTO ANGULAR ANGULAR CONTACT BALL BEARINGS



Dimensiones (mm) Dimension (mm)			Coeficiente de carga (KN) Load rating (KN)		Velocidad límite (rpm) Speed limit (Rpm)		Peso (Kg) Weight (Kg)	a (mm)	Sigla Designation
d (mm)	D (mm)	B (mm)	Dinámico Dynamic C	Estático Static C ₀	Lubricación Lubrication				
					Grasa Grease	Aceite Oil			
10	30	9	6.88	3.28	22950	27000	0.03	13	7200 B
12	32	10	7.46	3.72	19890	23400	0.036	14.4	7201 B
	37	12	10.39	4.9	18360	21600	0.063	16.3	7301 B
15	35	11	8.66	4.7	18360	21600	0.045	16	7202 B
	42	13	12.74	6.57	15300	18000	0.081	18	7302 B
17	40	12	10.88	5.98	15300	18000	0.064	18	7203 B
	47	14	15.58	8.13	14535	17100	0.11	20.4	7303 B
20	47	14	13.03	7.5	13770	16200	0.11	21	7204 B
	52	15	18.62	10.19	12240	14400	0.15	22.8	7304 B
25	52	15	15.29	10	11475	13500	0.13	23.7	7205 B
	62	17	25.48	15.29	10710	12600	0.24	26.8	7305 B
30	62	16	23.32	15.29	9945	11700	0.21	27.3	7206 B
	72	19	33.81	20.78	9180	10800	0.37	31	7306 B
35	72	17	30.09	20.38	8415	9900	0.3	31	7207 B
	80	21	38.22	24.01	7650	9000	0.49	35	7307 B
40	80	18	35.67	25.48	7650	9000	0.38	34	7208 B
	90	23	48.41	32.83	6885	8100	0.64	39	7308 B
45	85	19	36.95	27.44	6885	8100	0.43	37	7209 B
	100	25	59.29	40.67	6120	7200	0.86	43	7309 B
50	90	20	38.22	29.89	6502.5	7650	0.47	39	7210 B
	110	27	72.62	49.98	5737.5	6750	1.13	47	7310 B
55	100	21	47.82	37.24	5737.5	6750	0.62	43	7211 B
	120	29	83.5	58.8	5125.5	6030	1.48	51	7311 B
60	110	22	56.06	44.59	5355	6300	0.83	47	7212 B
	130	31	93.69	68.11	4590	5400	1.75	55	7312 B
65	120	23	64.97	52.92	4819.5	5670	1	50	7213 B
	140	33	105.84	78.4	4284	5040	2.1	60	7313 B
70	125	24	70.07	58.8	4590	5400	1.1	53	7214 B
	150	35	116.62	88.2	4054.5	4770	2.55	64	7314 B
75	130	25	71.34	62.72	4284	5040	1.18	56	7215 B
	160	37	122.5	96.04	3825	4500	3.06	68	7315 B
80	170	39	140.14	115.64	3442.5	4050	3.7	72	7316 B
85	150	28	93.69	81.34	3825	4500	1.83	63	7217 B
	180	41	143.08	109.76	3289.5	3870	4.26	76	7317 B
90	160	30	105.84	94.57	3442.5	4050	2.12	67	7218 B
	190	43	152.88	131.32	3060	3600	4.98	80	7318 B

Nota: Para el montaje de rodamientos de una hilera de bolas con contacto angular emparejados contactar nuestro servicio técnico
 Note: To use angular contact ball bearing twin, please contact our technical dept.

**RODAMIENTOS DE UNA HILERA DE BOLAS CON CONTACTO ANGULAR
ANGULAR CONTACT BALL BEARINGS**

Dimensiones (mm) Dimension (mm)			Coeficiente de carga (kN) Load rating (kN)		Velocidad límite (rpm) Speed limit (Rpm)		Peso (Kg) Weight (Kg)	a (mm)	Sigla Designation
d (mm)	D (mm)	B (mm)	Dinámico Dynamic C	Estático Static C ₀	Lubrificación Lubrication				
					Grasa Grease	Aceite Oil			
95	170	32	121.52	105.84	3289.5	3870	2.68	72	7219 B
	200	45	164.64	147	2907	3420	5.77	84	7319 B
100	180	34	132.3	119.56	3060	3600	3.38	76	7220 B
	215	47	198.94	186.2	2754	3240	7.15	90	7320 B
105	190	36	143	102	2800	3400	4.10	80	7221 B
	225	49	203	163	2700	3050	8.80	94	7321 B
110	200	38	149.94	140.14	2907	3420	4.95	84	7222 B
	240	50	220.5	219.52	2448	2880	9.69	99	7322 B
120	180	28	87.1	69.5	2950	3100	2.40	77	1024 B
	215	40	161.7	159.74	2754	3240	5.89	90	7224 B
	260	55	238	208	2650	3100	14.5	107	7324 B
130	230	40	182.28	189.14	2601	3060	6.76	96	7226 B
	280	58	290.08	298.9	2142	2520	17.1	115	7326 B
140	210	33	111	91.5	2230	2600	3.80	90	7028 B
	250	42	195.02	207.76	2295	2700	8.83	103	7228 B
	300	62	276	255	2100	2550	21.5	123	7328 B
150	225	35	119	98	1800	2300	4.7	96	7030 B
	270	45	195	170	1850	2300	11.0	112	7230 B
	320	65	302	300	1720	2150	25.5	132	7330 B
160	290	48	199	180	1900	2600	13.5	119	7232 B
170	260	42	159	140	2000	2600	7.80	129	7034 B
	310	52	221	208	1900	2500	17.0	127	7234 B
	360	72	358	375	1400	2000	36.0	147	7334 B
180	280	46	195	180	1650	2200	10.9	119	7036 B
	320	52	251	245	2700	3200	17.5	131	7236 B
	380	75	371	400	1300	3800	42.0	156	7336 B
190	290	46	199	186	1800	2400	10.5	124	7038 B
	340	55	276	270	9500	2000	22.0	139	7238 B
	400	78	410	455	1150	1600	48.5	164	7338 B
200	310	51	225	220	1700	2200	13.5	132	7040 B
220	340	56	255	265	1400	1900	18.0	145	7044 B
	400	65	319	355	1200	1600	37.0	164	7244 B
240	360	56	260	275	1150	1600	19.0	154	7048 B
	440	72	365	415	1100	1500	50.0	180	7248 B
260	360	46	242	260	900	1400	13.5	113	71952 A
280	380	46	251	280	800	1300	15.0	119	71956 A
	420	65	351	415	900	1300	30.0	134	7056 A
	420	65	319	365	870	1280	30.0	179	7056 B
	500	80	442	550	800	1200	69.5	205	7256 B

Nota: Para el montaje de rodamientos de una hilera de bolas con contacto angular emparejados contactar nuestro servicio técnico
 Note: To use angular contact ball bearing twin, please contact our technical dept.

RODAMIENTOS DE UNA HILERA DE BOLAS CON CONTACTO ANGULAR
ANGULAR CONTACT BALL BEARINGS



Dimensiones (mm) Dimension (mm)			Coeficiente de carga (kN) Load rating (kN)		Velocidad límite (rpm) Speed limit (Rpm)		Peso (Kg) Weight (Kg)	a (mm)	Sigla Designation
d (mm)	D (mm)	B (mm)	Dinámico Dynamic C	Estático Static C ₀	Lubricación Lubrication				
					Grasa Grease	Aceite Oil			
300	460	74	423	530	950	1300	42.5	147	7060 A
	460	74	377	465	900	1200	42.5	196	7060 B
320	480	74	436	550	700	1100	44.5	153	7064 A
340	520	82	449	600	800	1100	61.5	223	7068 B
	620	92	715	1080	700	1000	126	248	7268 B
360	480	56	302	390	800	1200	28.5	205	71972 B
	540	82	520	710	600	900	62.5	171	7072 A
	650	95	650	950	700	1000	145	261	7272 B
380	480	31	199	280	340	860	10.0	140	70876 A
	520	65	397	540	500	900	41.5	163	71976 A
400	720	103	728	1120	710	950	190	288	7280 B
420	560	65	364	510	810	1100	239	44.5	71984 B
	620	90	540	780	710	960	263	88.5	7084 B
460	580	37	265	390	760	1000	170	24.5	70892 A
	680	100	689	1080	610	800	215	120	7092 A
500	620	37	276	425	600	800	181	27.0	708/500 A
530	780	112	702	1200	550	740	332	180	70/530 B
560	680	56	397	655	680	810	208	41.5	718/560 A
	750	85	592	980	550	740	210	135	719/560 A
600	730	42	338	585	560	740	212	38.5	708/600 A
	870	118	884	1600	510	710	273	235	70/600 A
670	980	136	1210	2400	470	630	308	340	70/670 A
710	950	106	832	1830	810	1120	247	215	719/710 AC
750	920	78	618	1200	400	530	281	110	718/750 A

Nota: Para el montaje de rodamientos de una hilera de bolas con contacto angular emparejados contactar nuestro servicio técnico
 Note: To use angular contact ball bearing twin, please contact our technical dept.

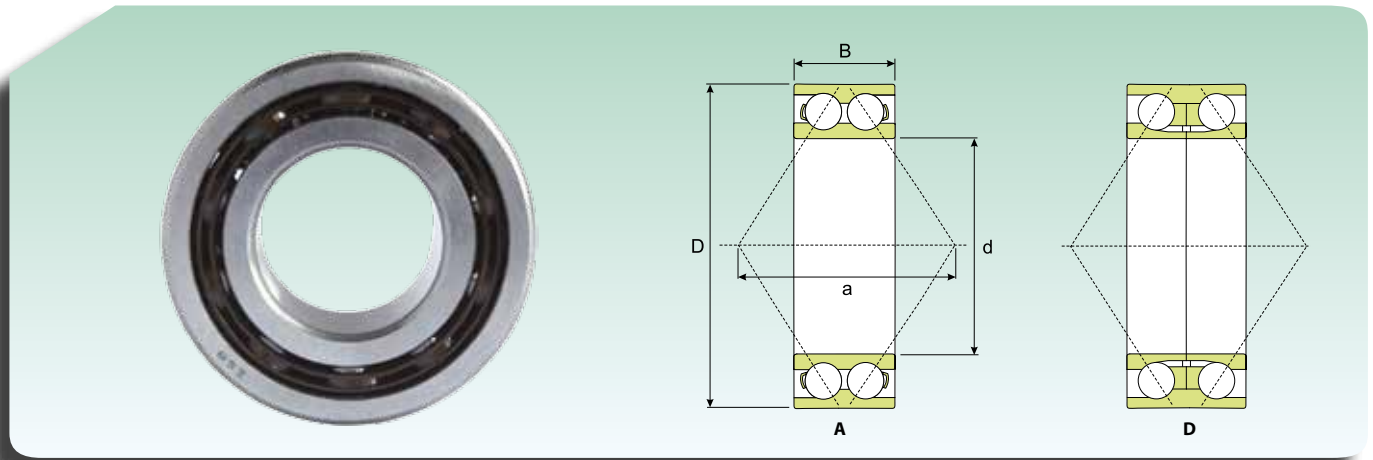
**RODAMIENTOS DE DOS HILERAS DE BOLAS CON CONTACTO ANGULAR
ANGULAR CONTACT BALL BEARINGS, DOUBLE ROW**

Dimensiones (mm) Dimension (mm)			Coeficiente de carga (KN) Load rating (KN)		Velocidad límite (rpm) Speed limit (Rpm)		Peso (Kg) Weight (Kg)	a (mm)	Sigla Designation	
d (mm)	D (mm)	B (mm)	Dinámico Dynamic C	Estático Static C ₀	Lubrificación Lubrication				Jaula metálica Metallic cage	Jaula de poliamida Polyamide cage
					Grasa Grease	Aceite Oil				
10	30	14	7.5	4.21	18360	21600	0.051	16	-	3200 ATN9
12	32	15.9	9.9	5.49	16830	19800	0.058	19	-	3201 ATN9
15	35	15.9	11	6.66	13770	16200	0.066	21	-	3202 ATN9
	42	19	14.8	9.11	12240	14400	0.13	24	-	3302 ATN9
17	40	17.5	14	8.62	12240	14400	0.095	23	-	3203 ATN9
	47	22.2	21.2	12.45	10710	12600	0.18	28	-	3303 ATN9
20	47	20.6	19.6	11.76	10710	12600	0.16	28	3204 A	3204 ATN9
	52	22.2	23.1	14.31	9945	11700	0.22	30	3304 A	3304 ATN9
25	52	20.6	21.2	14.01	9180	10800	0.19	30	3205 A	3205 ATN9
	62	25.4	31.4	19.99	8415	9900	0.35	36	3305 A	3305 ATN9
30	62	23.8	29.4	19.99	7650	9000	0.29	36	3206 A	3206 ATN9
	72	30.2	40.7	26.95	6885	8100	0.53	42	3306 A	3306 ATN9
35	72	27	39.2	27.44	6885	8100	0.44	42	3207 A	3207 ATN9
	80	34.9	51	34.79	6505	7650	0.71	47	3307 A	3307 ATN9
40	80	30.2	46.6	33.32	6120	7200	0.58	46	3208 A	3208 ATN9
	90	36.5	62.7	43.12	5740	6750	1.05	53	3308 A	3308 ATN9
	90	36.5	67.5	62.70	5695	6700	1.05	84	3308D	3308 DTN9
45	85	30.2	50	38.22	5740	6750	0.64	49	3209 A	3209 ATN9
	100	39.7	73.5	51.94	5130	6030	1.4	58	3309 A	3309 ATN9
	100	39.7	77.7	68.11	4590	5400	1.6	93	3309 D	-
50	90	30.2	50	38.22	5355	6300	0.66	52	3210 D	3210 ATN9
	110	44.4	88.2	62.72	4590	5400	1.95	65	3310 A	3310 ATN9
	110	44.4	91.7	83.30	4284	5040	2.15	102	3310 D	-
55	100	33.3	58.8	46.55	4820	5670	1.05	57	3211 A	3211 ATN9
	120	49.2	109.8	79.87	4055	4770	2.55	72	3311 A	3311 ATN9
	120	49.2	108.8	108	3825	4500	2.8	114	3311 D	-
60	110	36.5	72	57.33	4284	5040	1.4	63	3212 A	3212 ATN9
	130	54	124.5	93.10	3825	4500	3.25	78	3312 A	-
65	120	38.1	79	72.03	3672	4320	1.75	71	3213 A	-
	140	58.7	143.1	107.80	3445	4050	4.1	84	3313 A	-
70	125	39.7	86.6	78.40	3445	4050	1.9	74	3214 A	-
	150	63.5	159.7	122.50	3290	3870	5.05	89	3314 A	-
75	130	41.3	93.7	86.24	3445	4050	2.1	77	3215 A	-
	160	68.3	172.5	137.20	3060	3600	5.55	97	3315 A	-
80	140	44.4	103.9	93.10	3290	3870	2.65	82	3216 A	-
	170	68.3	178.4	152.88	2754	3240	6.8	101	3316 A	-
	170	68.3	186.2	192.00	2754	3240	7.55	158	3316 D	-

RODAMIENTOS DE DOS HILERAS DE BOLAS CON CONTACTO ANGULAR
ANGULAR CONTACT BALL BEARINGS, DOUBLE ROW

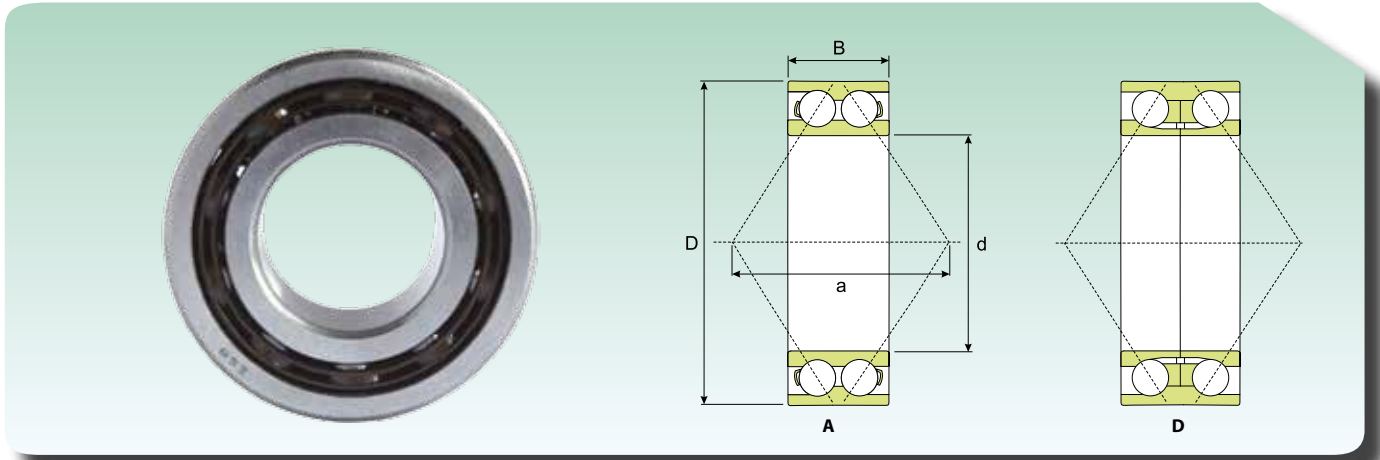

Dimensiones (mm) Dimension (mm)			Coeficiente de carga (KN) Load rating (KN)		Velocidad límite (rpm) Speed limit (Rpm)		Peso (Kg) Weight (Kg)	a (mm)	Sigla Designation	
d (mm)	D (mm)	B (mm)	Dinámico Dynamic C	Estático Static C ₀	Lubrificación Lubrication				Jaula metálica Metallic cage	Jaula de poliamida Polyamide cage
					Grasa Grease	Aceite Oil				
85	150	49.2	121.5	107.80	2907	3420	3.4	88	3217 A	-
	180	73	191.1	172.48	2601	3060	8.3	107	3317 A	-
90	160	52.4	127.4	117.60	2754	3240	4.15	94	3218 A	-
	190	73	191.1	176.40	2448	2880	9.25	112	3318 A	-
	190	73	220.5	245	2448	2880	10	178	3318 D	-
95	170	55.6	155.8	143.08	2601	3060	5	101	3219 A	-
	200	77.8	220.5	211.68	2295	2700	11	118	3319 A	-
	200	77.8	237.2	269.50	2295	2700	12	189	3319 D	-
100	180	60.3	157	173	2320	2780	6.1	118	3220	-
	180	60.3	174.4	162.68	2448	2880	6.1	107	3220 A	-
	215	82.6	255	290	2300	2700	13.5	139	3320	-
	215	82.6	260	245	2220	2600	15.5	199	3320 D	-
	215	82.6	249.9	249.90	2142	2520	13.5	127	3320 A	-
105	190	65.1	168	186	2120	2450	7.4	124	3221	-
110	200	69.8	207.8	207.76	2142	2520	8.8	119	3222 A	-
	240	92.1	307	300	2080	2400	21.5	217	3322 D	-
	240	92.1	285.2	298.90	1989	2340	19	142	3322 A	-
120	260	106	314	390	-	-	27	243	3324	-

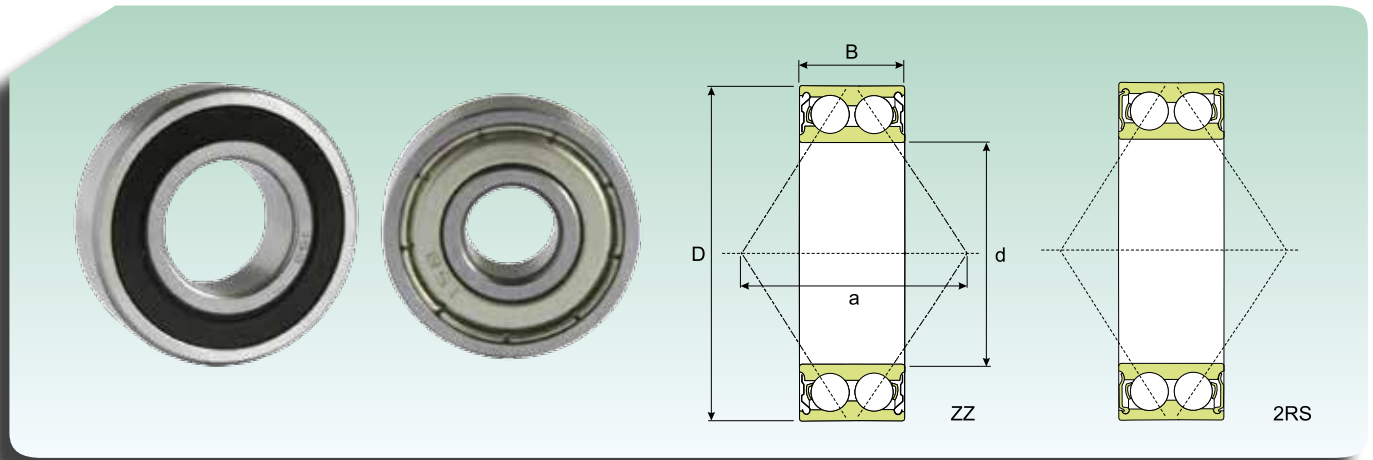
**RODAMIENTOS DE DOS HILERAS DE BOLAS CON CONTACTO ANGULAR ,BLINDADOS
ANGULAR CONTACT BALL BEARINGS, DOUBLE ROW - SEALED**

Dimensiones (mm) Dimension (mm)			Coeficiente de carga (KN) Load rating (KN)		Velocidad límite (rpm) Speed limit (Rpm)		Peso (Kg) Weight (Kg)	a (mm)	Sigla Designation	
d (mm)	D (mm)	B (mm)	Dinámico Dynamic C	Estático Static C ₀	Lubrificación Lubrication				Con blindajes With shield	Con obturaciones With seal
					ZZ	2RS				
10	30	14	7.46	4.2	22800	16150	0.051	16	3200-ZZ	3200-2RS
12	32	15.9	9.90	5.49	20900	14250	0.058	19	3201-ZZ	3201-2RS
15	35	15.9	10.98	6.66	17100	13300	0.066	21	3202-ZZ	3202-2RS
	42	19	14.80	9.11	15200	11400	0.13	24	3302-ZZ	3302-2RS
17	40	17.5	14.01	8.62	15200	11400	0.1	23	3203-ZZ	3203-2RS
	47	22.2	21.17	12.45	13300	10450	0.18	28	3303-ZZ	3303-2RS
20	47	20.6	19.60	11.76	13300	9500	0.15	28	3204-ZZ	3204-2RS
	52	22.2	23.13	14.31	12350	8550	0.21	30	3304-ZZ	3304-2RS
25	52	20.6	21.17	14.01	11400	8075	0.18	30	3205-ZZ	3205-2RS
	62	25.4	31.36	19.99	10450	7125	0.35	36	3305-ZZ	3305-2RS
30	62	23.8	29.40	19.99	9500	7125	0.27	36	3206-ZZ	3206-2RS
	72	30.2	40.67	26.95	8550	5985	0.52	42	3306-ZZ	3306-2RS
35	72	27	39.20	27.44	8550	5985	0.44	42	3207-ZZ	3207-2RS
	80	34.9	50.96	34.79	8075	5700	0.73	47	3307-ZZ	3307-2RS
40	80	30.2	46.55	33.32	7600	5320	0.57	46	3208-ZZ	3208-2RS
	90	36.5	62.72	43.12	7125	4750	0.93	53	3308-ZZ	3308-2RS
45	85	30.2	49.98	38.22	7125	5035	0.63	49	3209-ZZ	3209-2RS
	100	39.7	73.50	51.94	6365	4560	1.4	58	3309-ZZ	3309-2RS
50	90	30.2	49.98	38.22	6650	4560	0.65	57	3210-ZZ	3210-2RS
	110	44.4	88.20	62.72	5700	4085	1.95	61	3310-ZZ	3310-2RS
55	100	33.3	58.80	46.55	5985	4275	1.05	63	3211-ZZ	3211-2RS
	120	49.2	109.76	79.87	5035	3610	2.55	66	3311-ZZ	3311-2RS
60	110	36.5	72.03	57.33	5320	3800	1.4	63	3212-ZZ	3212-2RS
	130	54	124.46	93.10	4750	-	3.25	78	3312-ZZ	-
65	120	38.1	78.99	72.03	4560	-	1.75	71	3213-ZZ	3213-2RS
	140	58.7	143.08	107.80	4275	-	4.1	84	3313-ZZ	3313-2RS
70	125	39.7	86.63	78.4	4275	-	1.9	74	3214-ZZ	3214-2RS
	150	63.5	159.74	122.5	4085	-	5.05	89	3314-ZZ	3314-2RS
75	130	41.3	93.69	86.24	4275	-	2.1	77	3215-ZZ	3215-2RS
	160	68.3	172.48	137.20	3800	-	5.6	97	3315-ZZ	3315-2RS
80	140	44.4	98.98	131.32	3800	-	2.65	91	3216-ZZ	3216-2RS
	170	68.3	172.48	207.76	3400	-	6.95	112	3316-ZZ	3316-2RS
85	150	49.2	109	143	3600	-	3.4	97	3217-ZZ	3217-2RS
90	160	52.4	125	169	3400	-	4.15	104	3218-ZZ	3218-2RS
95	170	55.6	144	200	3200	-	5	111	3219-ZZ	3219-2RS
100	180	60.3	155	215	3000	-	6.1	118	3220-ZZ	3220-2RS



Rodamientos de bolas con cuatro puntos de contacto

Four-points contact ball bearings

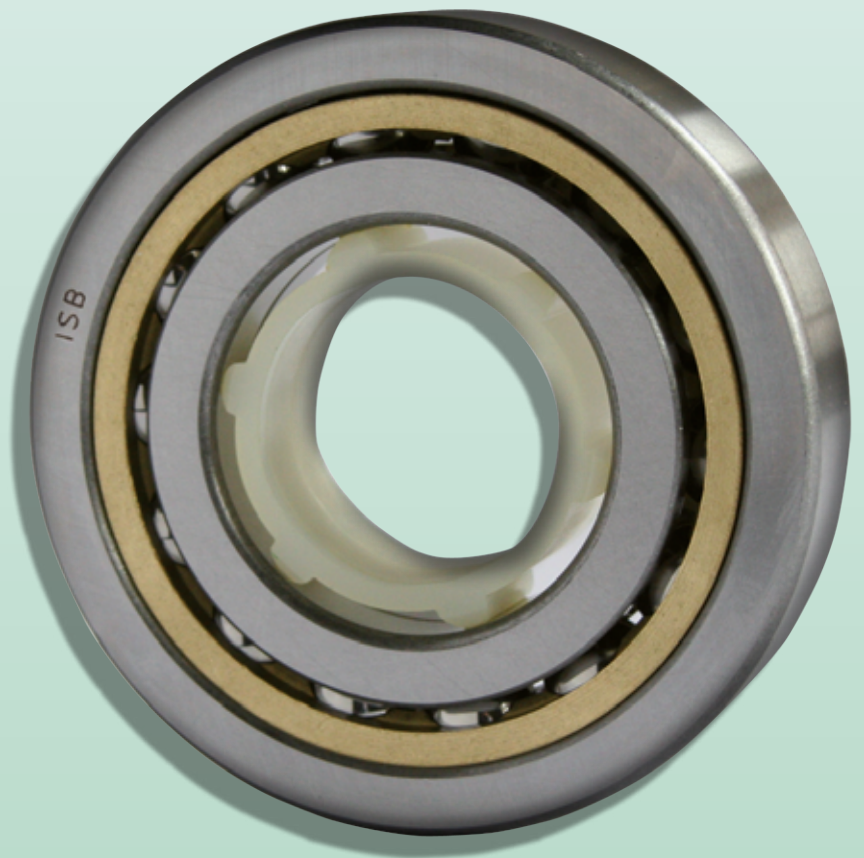

RODAMIENTOS DE BOLAS CON CUATRO PUNTOS DE CONTACTO

Los rodamientos **ISB**[®] con cuatro puntos de contacto, son rodamientos de una hilera de bolas con contacto angular, con caminos de rodadura proyectados para soportar cargas axiales en ambos sentidos y ocupan un espacio axial mucho menor respecto a los rodamientos **ISB**[®] de dos hileras de bolas con contacto angular.

Se ofrecen dos gamas, QJ2 y QJ3 en las versiones:

- Diseño estándar
- Diseño con ranura de bloqueo

RODAMIENTOS DE DISEÑO ESTÁNDAR

Realizados para resistir a cargas axiales, tienen un ángulo de contacto de 35°. El aro se puede desmontar en dos mitades; esta peculiaridad permite la introducción dentro del rodamiento de otro número de bolas, con una elevada capacidad de carga. Los rodamientos **ISB**[®] de bolas con cuatro puntos de contacto son desarmables (**Fig. 1**).

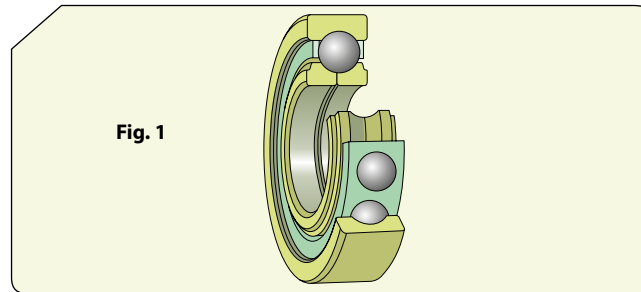

FOUR-POINTS CONTACT BALL BEARINGS

ISB[®] four-point contact bearings are single row angular contact ball bearings with raceways designed to withstand axial loads from both directions; they occupy much less axial space compared to *ISB*[®] double row angular contact ball bearings.

They are supplied in two ranges, QJ2 and QJ3 in the following versions:

- Standard
- With locating slots

STANDARD BEARINGS

They are designed to withstand axial loads and their contact angle is 35°. The ring can be separated into two halves so that the bearing can incorporate a large number of balls, which ensures a high load carrying capacity. *ISB*[®] four-point contact ball bearings are separable (**Fig. 1**).

RODAMIENTOS CON RANURAS DE BLOQUEO

Son muchas las aplicaciones en las cuales se combina un rodamiento radial y un rodamiento de bolas con cuatro puntos de contacto, para lograr que el aro exterior no gire en sentido circular. Por esta razón los rodamientos con sufijo N2 tienen dos ranuras en el aro exterior, ubicadas a 180° entre sí (**Fig. 2**).

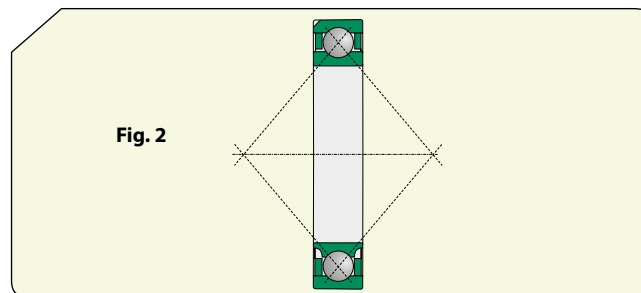

BEARINGS WITH LOCATING SLOTS

There are many applications in which one single row deep groove radial bearing is combined with a four-point contact ball bearing so that the outer ring does not turn circularly. For this reason, bearings with suffix N2 have two slots in the outer ring, positioned at 180° one compared to the other (**Fig. 2**).

DIMENSIONES

Las dimensiones generales de los rodamientos **ISB**[®] de bolas con cuatro puntos de contacto respetan la norma ISO 15:1998.

TOLERANCIAS

Los rodamientos **ISB**[®] de bolas con cuatro puntos de contacto se fabrican según la clase de tolerancia normal. Siguiendo las especificaciones de la clase de tolerancia P6 algunas dimensiones están disponibles con mayor precisión.

DIMENSIONS

The overall dimensions of *ISB*[®] four-point contact ball bearings comply with standard ISO 15:1998.

TOLERANCES

ISB[®] four-point contact ball bearings are manufactured pursuant to the Normal tolerance class. Following the specifications of tolerance class P6, some sizes are also available with higher precision ratings.

JUEGO INTERNO

Los rodamientos **ISB**® con cuatro puntos de contacto se fabrican de serie con juego interior axial normal.

DESALINEACIÓN

La capacidad de tolerar la desalineación entre aro interior y exterior es limitada; por lo tanto la capacidad de compensación de eventuales errores de alineación y tolerancia respecto a las inflexiones del eje resultan limitadas.

JAULAS

La única jaula prevista para este tipo de rodamientos es la mecanizada de latón, de tipo-ventana, centrada en el aro exterior (**Fig. 3**).

INTERNAL CLEARANCE

ISB® four-point contact ball bearings are manufactured standard with Normal internal axial clearance.

MISALIGNMENT

The misalignment tolerance capacity between inner ring and outer ring is limited, consequently the ability to compensate any misalignments and tolerance compared to the shaft deflections is limited.

CAGES

The only cage available for this type of bearing is the solid machined window-type brass cage, centred on the outer ring (**Fig. 3**).

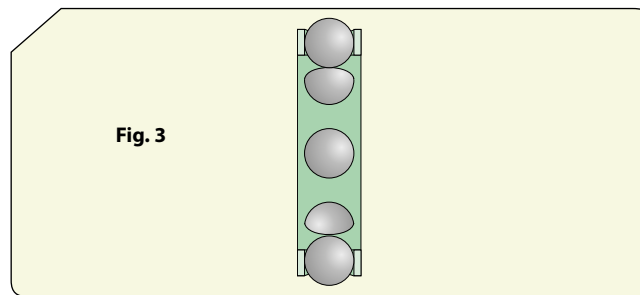

DESIGNACIONES SUPLEMENTARIAS

- C2** Juego axial interior inferior en la clase normal
- C3** Juego axial interior superior en la clase normal
- C4** Juego axial interior superior en la clase C3
- M** Jaula mecanizada de latón, de tipo-ventana, centrada en el aro exterior
- N2** Dos ranuras de bloqueo en la cara lateral ancha del aro exterior, a 180° una de la otra
- P6** Precisión dimensional y de rotación según la clase de tolerancia 6 de la norma ISO

SUPPLEMENTARY DESIGNATIONS

- C2** Internal axial clearance smaller than Normal
- C3** Internal axial clearance greater than Normal
- C4** Internal axial clearance greater than class C3
- M** Solid machined window-type brass cage, centred on the outer ring
- N2** Two locating slots on the wide side face of the outer ring, at 180° one compared to the other
- P6** Dimensional and rotation precision according to tolerance class 6 of ISO standard

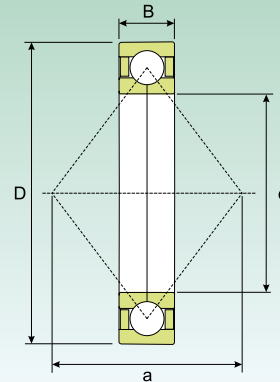
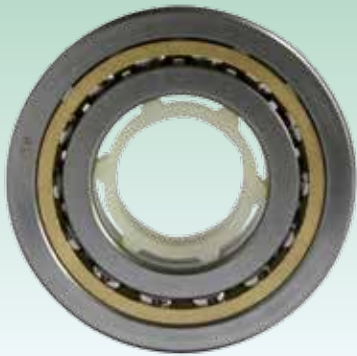
**RODAMIENTOS DE BOLAS CON CUATRO PUNTOS DE CONTACTO
FOUR-POINTS CONTACT BALL BEARINGS**

Dimensiones (mm) Dimension (mm)			Coeficiente de carga (KN) Load rating (KN)		Velocidad límite (rpm) Speed limit (Rpm)		Peso (Kg) Weight (Kg)	a (mm)	Sigla Designation
d (mm)	D (mm)	B (mm)	Dinámico Dynamic C	Estático Static C ₀	Lubrificación Lubrication				
					Grasa Grease	Aceite Oil			
15	35	11	12.5	8.1	27540	32400	0.062	18	QJ 202 N2 M
17	40	12	15.6	10.4	22950	27000	0.082	20	QJ 203 N2 M
	47	14	22.9	14.7	21420	25200	0.14	22	QJ 303 N2 M
20	52	15	31.4	21.2	18360	21600	0.18	25	QJ 304 N2 M
25	52	15	26.5	20.8	16830	19800	0.16	27	QJ 205 N2 M
	62	17	38.2	27.4	15300	18000	0.29	30	QJ 305 N2 M
30	62	16	36.8	29.9	14535	17100	0.24	32	QJ 206 N2 M
	72	19	51.9	40.7	13005	15300	0.42	36	QJ 306 N2 M
35	72	17	48	40.7	13005	15300	0.36	37	QJ 207 N2 M
	80	21	62.7	50.0	11475	13500	0.57	40	QJ 307 N2 M
40	80	18	54.9	48.0	11475	13500	0.45	42	QJ 208 N2 M
	90	23	76.4	62.7	10710	12600	0.78	46	QJ 308 N2 M
45	85	19	61.7	54.9	10710	12600	0.52	46	QJ 209 N2 M
	100	25	98	81	9180	10800	1.05	51	QJ 309 N2 M
50	90	20	64.2	59	9945	11700	0.59	49	QJ 210 N2 M
	110	27	115	98	8415	9900	1.35	56	QJ 310 N2 M
55	100	21	83	81	8415	9900	0.77	54	QJ 211 N2 M
	120	29	135	116	7650	9000	1.75	61	QJ 311 N2 M
60	110	22	95	91	7650	9000	0.99	60	QJ 212 N2 M
	130	31	153	134	6885	8100	2.15	67	QJ 312 N2 M
65	120	23	108	109	7268	8550	1.20	65	QJ 213 N2 M
	140	33	173	152	6503	7650	2.70	72	QJ 313 N2 M
70	125	24	118	119	6885	8100	1.30	68	QJ 214 N2 M
	150	35	196	176	6120	7200	3.15	77	QJ 314 N2 M
75	130	25	123	129	6502	7650	1.45	72	QJ 215 N2 M
	160	37	211	196	5737	6750	3.90	82	QJ 315 N2 M
80	140	26	143	152	6120	7200	1.85	77	QJ 216 N2 M
	170	39	227	223	5355	6300	4.60	88	QJ 316 N2 M
85	150	28	152	169	5737	6750	2.25	83	QJ 217 N2 M
	180	41	245	249	5125	6030	5.45	93	QJ 317 N2 M
90	160	30	182	196	5355	6300	2.75	88	QJ 218 N2 M
	190	43	279	298	4819	5670	6.45	98	QJ 318 N2 M
95	170	32	207	227	5125	6030	3.35	93	QJ 219 N2 M
	200	45	298	333	4590	5400	7.45	103	QJ 319 N2 M
100	180	34	231	259	4819	5670	4.05	98	QJ 220 N2 M
	215	47	338	392	4284	5040	9.30	110	QJ 320 N2 M

RODAMIENTOS DE BOLAS CON CUATRO PUNTOS DE CONTACTO
FOUR-POINTS CONTACT BALL BEARINGS

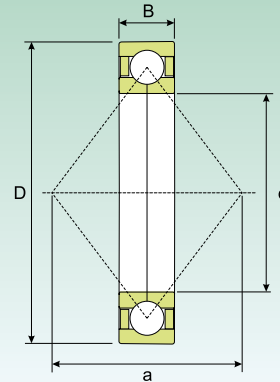
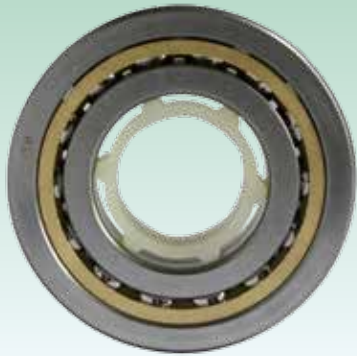

Dimensiones (mm) Dimension (mm)			Coeficiente de carga (KN) Load rating (KN)		Velocidad límite (rpm) Speed limit (Rpm)		Peso (Kg) Weight (Kg)	a (mm)	Sigla Designation
d (mm)	D (mm)	B (mm)	Dinámico Dynamic C	Estático Static C ₀	Lubrificación Lubrication				
					Grasa Grease	Aceite Oil			
110	170	28	146	140	4500	5300	2.5	98	QJ 1022
	200	38	274	318	4284	5040	5.60	109	QJ 222 N2 M
	240	50	382	470	3672	4320	12.5	123	QJ 322 N2 M
120	215	40	294	357	3825	4500	6.95	117	QJ 224 N2 M
	260	55	406	519	3442	4050	16	133	QJ 324 N2 M
	260	86	377	390	3500	4100	24.0	185	QJ 2324 N2
130	230	40	303	392	3672	4320	7.75	126	QJ 226 N2 M
	280	58	445	597	3060	3600	19.5	144	QJ 326 N2 M
	280	93	416	465	3200	3800	30.5	200	QJ 2326 N2
140	250	42	338	465	3289	3870	9.85	137	QJ 228 N2 M
	300	62	490	681	2907	3420	24	154	QJ 328 N2 M
150	225	35	216	228	3150	3750	5.25	131	QJ 1030
	270	45	392	558	3060	3600	12.5	147	QJ 230 N2 M
	320	65	519	749	2754	3240	29	165	QJ 330 N2 M
160	240	38	247	260	3000	3550	6.45	140	QJ 1032
	290	48	441	656	2907	3420	15.5	158	QJ 232 N2 M
	340	68	558	862	2601	3060	34.5	175	QJ 332 N2 M
170	260	42	286	305	2800	3200	8.60	151	QJ 1034
	310	52	445	705	2601	3060	19.5	168	QJ 234 N2 M
	360	72	641	1019	2448	2880	41.5	186	QJ 334 N2 M
180	280	46	338	380	2720	3100	11.0	161	QJ 1036
	320	52	465	749	2601	3060	20.5	175	QJ 236 N2 M
	380	75	666	999	2295	2700	47.5	196	QJ 336 N2 M
190	290	46	338	380	2250	2700	11.5	168	QJ 1038
	400	78	688	1136	2142	2520	49.0	207	QJ 338 N2 M
200	360	58	529	896	2295	2700	28.5	196	QJ 240 N2 M
	310	51	390	465	2000	2400	15.0	179	QJ 1040
220	340	56	442	560	1500	2000	19.5	196	QJ 1044
	400	78	592	800	1300	1650	45.5	310	QJ 1244
	460	88	780	1140	1200	1500	78.0	238	QJ 344 N2
240	360	56	449	585	1100	1500	21.0	210	QJ 1048
	440	72	650	930	1000	1450	53.0	238	QJ 248 N2
	440	85	663	950	1000	1400	61.0	340	QJ 1248
260	360	46	390	510	1000	1400	15.0	217	QJ 1952 N2
	480	90	741	1120	950	1300	78.5	370	QJ 1252
280	420	65	553	780			33.5	245	QJ 1056
320	480	74	663	1040	800	1150	50.0	280	QJ 1064
	580	105	923	1560	820	1100	130	450	QJ 1264

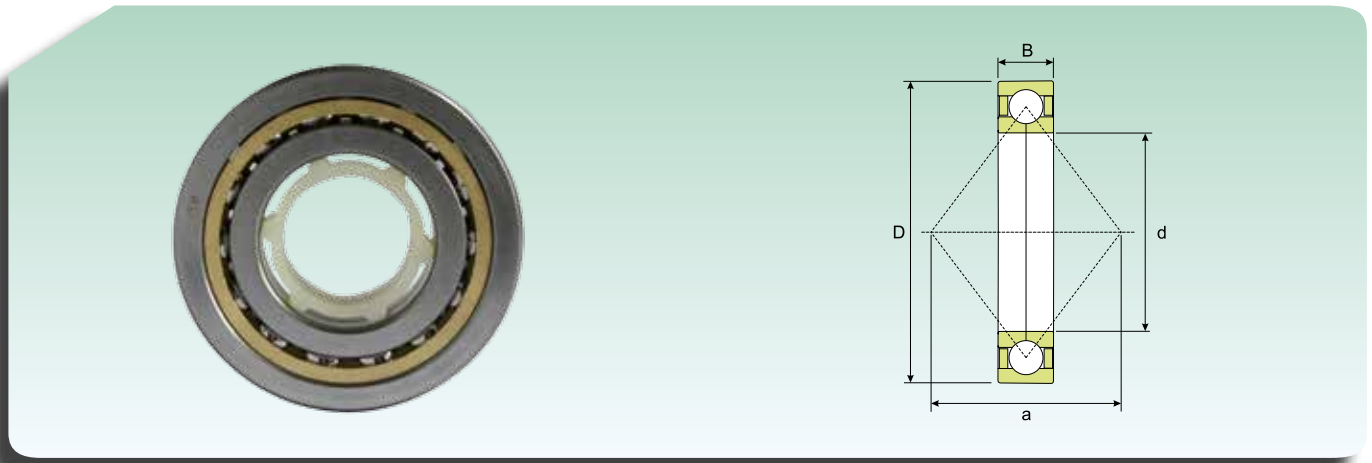
**RODAMIENTOS DE BOLAS CON CUATRO PUNTOS DE CONTACTO
FOUR-POINTS CONTACT BALL BEARINGS**

Dimensiones (mm) Dimension (mm)			Coeficiente de carga (KN) Load rating (KN)		Velocidad límite (rpm) Speed limit (Rpm)		Peso (Kg) Weight (Kg)	a (mm)	Sigla Designation
d (mm)	D (mm)	B (mm)	Dinámico Dynamic C	Estático Static C ₀	Lubrificación Lubrication				
					Grasa Grease	Aceite Oil			
340	520	82	780	1290	700	950	67.5	301	QJ 1068
	620	118	1060	1900	650	900	165	408	QJ 1268
360	650	122	1100	2000	650	850	190	505	QJ 1272
380	680	132	1170	2200	600	800	220	530	QJ 1276
440	600	74	761	1370	600	800	65.0	364	QJ 1988
460	680	100	1040	1960	550	750	130	399	QJ 1092



Rodamientos de bolas a rótula

Self-aligning ball bearings



RODAMIENTOS DE BOLAS A RÓTULA

El rodamiento **ISB**[®] de bolas a rótula está compuesto por dos hileras de bolas y un camino de rodadura esférico único en el aro exterior. Este tipo de diseño permite que el rodamiento sea autoalineable y no sufra ningún tipo de problema de desalineación. Ha sido diseñado para su utilización en aplicaciones donde se prevé la posibilidad de errores de alineación o cuando se presenta una significativa inflexión del eje. Resulta particularmente idóneo para trabajar a elevadas velocidades, ya que, dentro de la amplia gama de rodamientos, los rodamientos **ISB**[®] de bolas a rótula son los que presentan la menor fricción.

Estos tipos de rodamientos se fabrican en tres versiones diferentes:

- Rodamientos abiertos con un diseño básico (**Fig. 1a**);
- Rodamientos obturados (**Fig. 1b**);
- Rodamientos abiertos con aro interior prolongado (**Fig. 1c**).

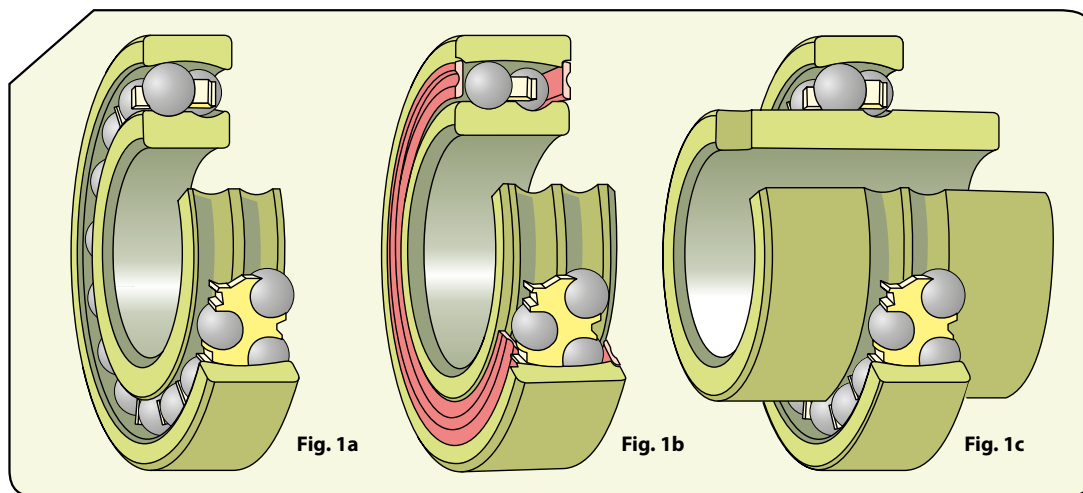

DISEÑO BÁSICO

Están disponibles con un agujero cilíndrico o, en ciertas gamas de tamaños, con un agujero cónico (conicidad 1:12). Tanto en el aro interior como también en el exterior, estos rodamientos tienen ranura anular y agujeros de lubricación.

RODAMIENTOS OBTURADOS

La variante prevista con obturaciones o juntas incorporadas está lubricada con una grasa con buena capacidad antióxido. Este tipo de lubricación está garantizada de por vida y elimina toda necesidad de mantenimiento (**Fig. 2**).

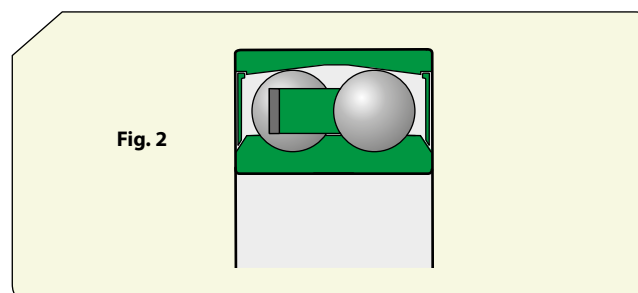

Las obturaciones incorporadas son de caucho acrilonitrilo-butadieno (NBR), material resistente al aceite y al desgaste y están reforzadas con una chapa de acero. La temperatura de servicio va de -40°C a +100°C y, sólo por breves intervalos, puede alcanzar los +120°C. El labio de la obturación ejerce una ligera presión contra

SELF-ALIGNING BALL BEARINGS

ISB[®] self-aligning ball bearings have two rows of balls and just one spherical raceway on the outer ring. This type of design means that the bearing is self-aligning and is not subjected to any misalignment problems.

It is designed to be used in applications where there could be misalignment errors or considerable shaft deflections. It is particularly suitable for working at high speeds because, out of the wide range of rolling bearings, **ISB**[®] self-aligning ball bearings are those with lowest friction.

These types of bearings are supplied in three different versions:

- Basic design open bearings (**Fig. 1a**);
- Sealed bearings (**Fig. 1b**);
- Open bearings with wider inner ring (**Fig. 1c**).

BASIC DESIGN VERSION

Available with cylindrical bore or tapered bore in certain dimensional ranges (taper 1:12). These bearings have annular groove and lubrication holes on the inner ring and also on the outer ring.

SEALED BEARINGS

This is the sealed variant lubricated with grease and with efficient rust-inhibiting capacity. This type of lubrication is guaranteed for life and means that the bearing is maintenance-free (**Fig. 2**).

The seals are made of Nitrile-Butadiene-Rubber (NBR), which is resistant to oil and wear and are reinforced with sheet steel. The operational temperature range is -40°C to +100°C, and up to +120°C just for short periods. The seal lip applies a slight pressure on a special smooth groove on the inner ring. Likewise

un chaflán liso en el aro interior. Como para aquellos de diseño básico, estos rodamientos se fabrican tanto con agujero cilíndrico como también cónico (conicidad 1:12). Los rodamientos obturados, antes del montaje, no se deberán lavar ni calentar a temperaturas superiores a los +80°C; el sufijo de la designación es 2RS.

for the basic design version, these bearings have a cylindrical bore and a tapered bore (taper 1:12). Before mounting, the sealed bearings should not be washed or heated to temperatures above +80°C; the designation suffix is 2RS.

RODAMIENTO CON ARO INTERIOR MÁS ANCHO

Son rodamientos específicos para ejes realizados por trefilado. La facilidad en el montaje y en el desmontaje constituyen una garantía de las particulares tolerancias del agujero. Se fijan axialmente en el eje gracias a un pasador o un tornillo (Fig. 3) que a su vez se introduce dentro de la cavidad prevista en un lado del aro, en modo tal que esté último no gire en el eje.

BEARINGS WITH WIDER INNER RING

They are specific drawn bearings for shafts; the ease of assembly and disassembly are guaranteed by the special tolerances of the bore, They are fitted axially on the shaft thanks to a pin or screw (Fig. 3), which in turn fits in the recess on one side of the ring so that the latter does not turn on the shaft.

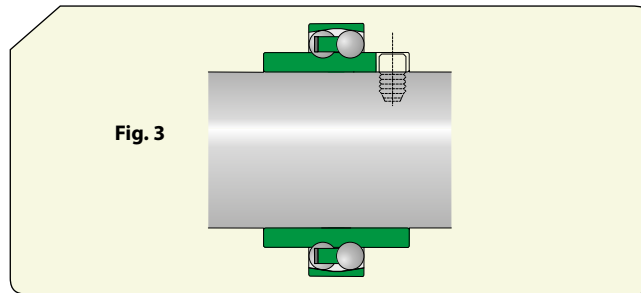

RODAMIENTOS CON MANGUITO

Los rodamientos con agujero cónico están fijados en un eje cilíndrico mediante manguitos de fijación o desmontaje. Éstos facilitan el montaje y el desmontaje. Los manguitos de desmontaje necesitan de un mecanismo de fijación axial en el eje, en cambio los manguitos de fijación no lo necesitan, razón por la cual éstos últimos se emplean más frecuentemente (Fig. 4).

BEARINGS WITH SLEEVE

Bearings with tapered bore are fitted on a cylindrical shaft by means of adapter and withdrawal sleeves. These facilitate assembly and disassembly. The withdrawal sleeves require an axial locking device on the shaft, whereas the adapter sleeves do not, consequently the latter are more popular (Fig. 4).

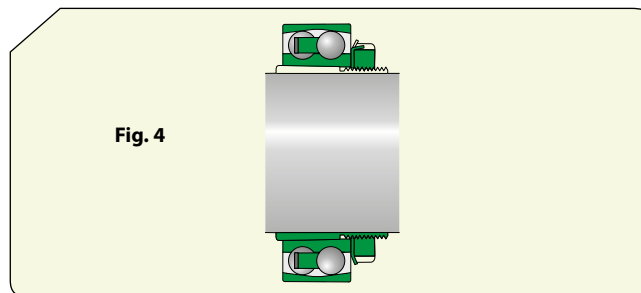

DIMENSIONES

Las dimensiones generales de los rodamientos ISB® de bolas a rótula respetan la norma ISO 15:1998.

DIMENSIONS

The overall dimensions of ISB® self-aligning ball bearings comply with standard ISO 15:1998.

TOLERANCIAS

Los rodamientos ISB® de bolas a rótula se fabrican generalmente con tolerancias normales de conformidad con la norma ISO 492:2002. Constituyen una excepción las versiones con aro más ancho, que cuentan con un agujero realizado con tolerancia JS7.

TOLERANCES

ISB® self-aligning ball bearings are usually manufactured with Normal tolerances pursuant to ISO 492:2002. The versions with wider inner ring are an exception and their bore belongs to tolerance class JS7.

DESALINEACIÓN

Pueden verificarse desalineaciones entre el aro interior y el exterior; las mismas sin embargo no inciden negativamente sobre las prestaciones, en virtud de la forma constructiva que caracteriza estos rodamientos.

MISALIGNMENT

Misalignments could occur between the inner ring and the outer ring, but they do not have a detrimental effect on performance thanks to their constructional design, which characterises such bearings.

JUEGO INTERNO

Además del juego interior radial normal, muchas versiones de los rodamientos **ISB**[®] de bolas a rótula se fabrican con un juego menor (C2), mayor (C3) o mucho mayor (C4).

JAULAS

Los rodamientos **ISB**[®] de bolas a rótula, en base a las dimensiones y a las series, se suministran con las siguientes jaulas:

- Jaula de chapa monobloque de acero (**Fig. 5a**),
- Jaula de chapa de acero en dos partes (**Fig. 5b**),
- Jaula moldeada por inyección en poliamida 6,6 reforzada con fibra de vidrio, sufijo TN9 (**Fig. 5c**),
- Jaula mecanizada de latón (**Fig. 5d**).

INTERNAL CLEARANCE

Together with the Normal internal radial clearance, many versions of **ISB**[®] self-aligning ball bearings are available with smaller clearance (C2), greater clearance (C3) or much greater clearance (C4).

CAGES

ISB[®] self-aligning ball bearings, based on the size and series, are supplied with the following cages:

- Single-piece pressed sheet steel cage (**Fig. 5a**),
- Two-piece sheet steel cage (**Fig. 5b**),
- Injection moulded cage made of polyamide 6,6 with fibre-glass reinforcement, centred on the balls, with suffix TN9 (**Fig. 5c**),
- Solid machined brass cage (**Fig. 5d**).

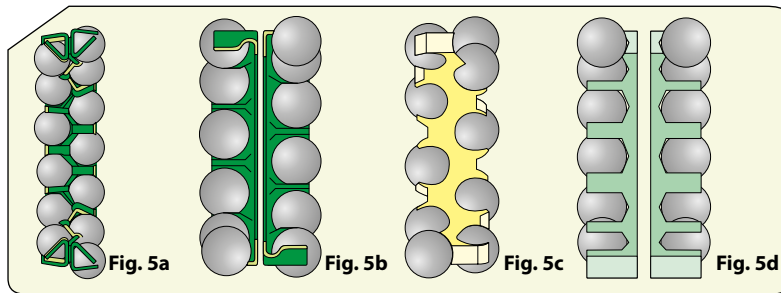

CAPACIDAD CARGA AXIAL

Cuando los rodamientos **ISB**[®] de bolas a rótula con manguito de fijación se montan en ejes trefilados sin apoyos, la capacidad de resistencia a las cargas axiales está en relación con el rozamiento entre el manguito y el eje.

DESIGNACIONES SUPLEMENTARIAS

- C3** Juego radial interior superior en la clase normal
K Agujero conico, conicidad 1:12
M Jaula mecanizada de latón centrada en las bolas
2RS Obturaciones de caucho acrilonitrilo-butadieno (NBR) con refuerzo de chapa de acero, de ambos lados del rodamiento
TN9 Jaula moldeada por inyección de montaje a presión, en poliamida 6,6 reforzada con fibras de vidrio centrada en las bolas

AXIAL LOAD CARRYING CAPACITY

When **ISB**[®] self-aligning ball bearings with adapters sleeve are fitted on drawn shafts without shoulders, the capacity to withstand axial loads depends on the friction between sleeve and shaft.

SUPPLEMENTARY DESIGNATIONS

- C3** Internal radial clearance greater than Normal,
K Tapered bore, taper 1:12
M Solid machined brass cage, centred on the balls
2RS Nitrile-Butadiene-Rubber (NBR) contact seals with sheet steel reinforcement, on both sides of the bearing
TN9 Injection moulded snap-type cage made of polyamide 6,6 with fibreglass reinforcement, centred on the balls

RODAMIENTOS DE BOLAS A RÓTULA
SELF-ALIGNING RADIAL BALL BEARINGS

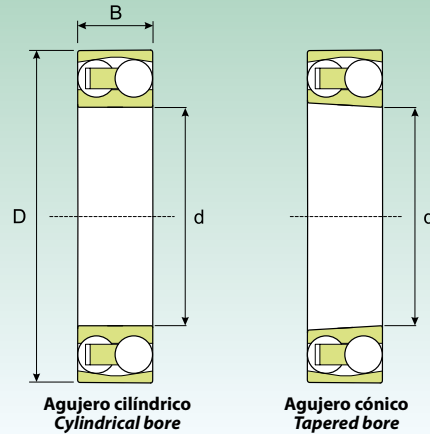

Dimensiones (mm) Dimension (mm)			Coeficiente de carga (KN) Load rating (KN)		Velocidad límite (rpm) Speed limit (Rpm)		Peso (Kg) Weight (Kg)	Sigla Designation	
d (mm)	D (mm)	B (mm)	Dinámico Dynamic C	Estático Static C ₀	Lubrificación Lubrication			Agujero cilíndrico Cylindrical bore	Agujero cónico Tapered bore
					Grasa Grease	Aceite Oil			
5	19	6	2,46	0,47	34425	40500	0,009	135 TN9	-
6	19	6	2,46	0,47	34425	40500	0,009	126 TN9	-
7	22	7	2,60	0,55	30600	36000	0,014	127 TN9	-
8	22	7	2,60	0,55	30600	36000	0,014	108 TN9	-
9	26	8	3,82	0,80	29070	34200	0,022	129 TN9	-
10	30	9	5,42	1,16	27540	32400	0,034	1200 TN9	-
	30	14	7,90	1,70	26010	30600	0,047	2200 TN9	-
12	32	10	6,12	1,40	24480	28800	0,04	1201 TN9	-
	32	14	8,35	1,86	22950	27000	0,053	2201 TN9	-
	37	12	9,17	2,12	21420	25200	0,072	1301	-
	37	17	11,47	2,65	21420	25200	0,095	2301	-
15	35	11	7,26	1,72	21420	25200	0,049	1202 TN9	-
	35	14	8,54	2,00	19890	23400	0,06	2202 TN9	-
	42	13	10,58	2,55	18360	21600	0,094	1302 TN9	-
	42	17	11,66	2,84	18360	21600	0,12	2302	-
17	40	12	8,66	2,16	18360	21600	0,073	1203 TN9	-
	40	16	10,39	2,50	18360	21600	0,088	2203 TN9	-
	47	14	12,45	3,33	15300	18000	0,12	1303 TN9	-
	47	19	14,31	3,48	16830	19800	0,16	2303	-
20	47	14	12,45	3,33	15300	18000	0,12	1204 TN9	1204 KTN9
	47	18	16,46	4,07	15300	18000	0,14	2204 TN9	-
	52	15	14,01	3,92	13770	16200	0,16	1304 TN9	-
	52	21	17,84	4,66	14535	17100	0,22	2304	-
25	52	15	14,01	3,92	13770	16200	0,14	1205 TN9	1205 KTN9
	52	18	16,46	4,31	13770	16200	0,16	2205 TN9	2205 KTN9
	62	17	18,62	5,29	11475	13500	0,26	1305 TN9	1305 KTN9
	62	24	26,46	6,96	12240	14400	0,34	2305	-
30	62	16	15,29	4,56	11475	13500	0,22	1206 TN9	1206 KTN9
	62	20	23,32	6,57	11475	13500	0,26	2206 TN9	2206 KTN9
	72	19	22,05	6,66	9945	11700	0,39	1306 TN9	1306 KTN9
	72	27	30,58	8,62	9945	11700	0,5	2306	2306 K
35	72	17	18,62	5,88	9945	11700	0,32	1207 TN9	1207 KTN9
	72	23	30,09	8,62	9180	10800	0,4	2207 TN9	2207 KTN9
	80	21	25,97	8,33	8415	9900	0,51	1307 TN9	1307 KTN9
	80	31	38,91	10,98	9180	10800	0,68	2307 TN9	2307 KTN9
40	80	18	19,50	6,81	8415	9900	0,42	1208 TN9	1208 KTN9
	80	23	31,26	9,80	8415	9900	0,51	2208 TN9	2208 KTN9
	90	23	33,12	10,98	7267,5	8550	0,68	1308 TN9	1308 KTN9
	90	33	52,92	15,68	7650	9000	0,93	2308 TN9	2308 KTN9

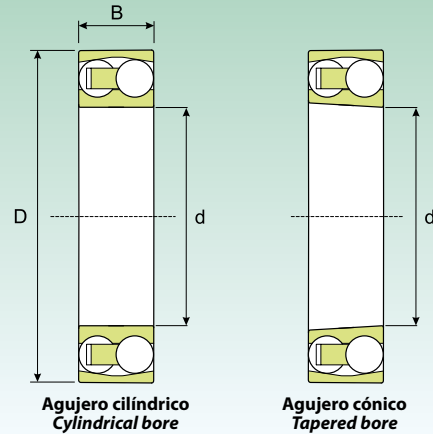
**RODAMIENTOS DE BOLAS A RÓTULA
SELF-ALIGNING RADIAL BALL BEARINGS**

Dimensiones (mm) Dimension (mm)			Coeficiente de carga (kN) Load rating (kN)		Velocidad límite (rpm) Speed limit (Rpm)		Peso (Kg) Weight (Kg)	Sigla Designation	
d (mm)	D (mm)	B (mm)	Dinámico Dynamic C	Estático Static C ₀	Lubrificación Lubrication			Agujero cilíndrico Cylindrical bore	Agujero cónico Tapered bore
					Grasa Grease	Aceite Oil			
45	85	19	22,44	7,64	8415	9900	0,47	1209 TN9	1209 KTN9
	85	23	31,85	10,39	7650	9000	0,55	2209 TN9	2209 KTN9
	100	25	38,22	13,13	6502,5	7650	0,96	1309 TN9	1309 KTN9
	100	36	62,43	18,91	6885	8100	1,25	2309 TN9	2309 KTN9
50	90	20	25,97	8,97	7650	9000	0,53	1210 TN9	1210 KTN9
	90	23	33,12	10,98	7267,5	8550	0,6	2210 TN9	2210 KTN9
	110	27	42,73	13,72	6120	7200	1,2	1310 TN9	1310 KTN9
	110	40	62,43	19,60	7267,5	8550	1,65	2310	2310 K
55	100	21	27,05	10,39	6885	8100	0,71	1211 TN9	1211 KTN9
	100	25	38,22	13,13	6502,5	7650	0,81	2211 TN9	2211 KTN9
	120	29	49,69	17,64	5737,5	6750	1,6	1311 TN9	1311 KTN9
	120	43	74,58	23,52	5737,5	6750	2,1	2311	2311 K
60	110	22	30,58	11,96	6502,5	7650	0,9	1212 TN9	1212 KTN9
	110	28	47,82	16,66	6120	7200	1,1	2212 TN9	2212 KTN9
	130	31	57,33	21,56	4819,5	5670	1,95	1312 TN9	1312 KTN9
	130	46	85,36	27,93	5355	6300	2,6	2312	2312 K
65	120	23	34,40	13,72	5355	6300	1,15	1213 TN9	1213 KTN9
	120	31	56,06	19,60	5355	6300	1,45	2213 TN9	2213 KTN9
	140	33	63,70	24,99	4590	5400	2,45	1313 TN9	1313 KTN9
	140	48	93,69	31,85	4819,5	5670	3,25	2313	2313 K
70	125	24	35,08	14,31	5355	6300	1,25	1214 TN9	1214 KTN9
	125	31	43,32	16,66	5125,5	6030	1,5	2214	2214 K
	150	35	72,62	26,95	4590	5400	3	1314	1314 K
	150	51	108,78	36,75	4590	5400	3,9	2314	2314 K
75	130	25	38,22	15,29	5125,5	6030	1,35	1215	1215 K
	130	31	57,33	21,56	4819,5	5670	1,6	2215 TN9	2215 KTN9
	160	37	77,71	29,40	4284	5040	3,55	1315	1315 K
	160	55	121,52	42,14	4284	5040	4,7	2315	2315 K
80	140	26	38,91	16,66	4590	5400	1,65	1216	1216 K
	140	33	63,70	24,99	4590	5400	2	2216 TN9	2216 KTN9
	170	39	86,63	32,83	4054,5	4770	4,2	1316	1316 K
	170	58	132,30	48,02	4054,5	4770	6,1	2316	2316 K
85	150	28	47,82	20,38	4284	5040	2,05	1217	1217 K
	150	36	57,33	23,13	4284	5040	2,5	2217	2217 K
	180	41	95,55	37,24	3672	4320	5	1317	1317 K
	180	60	137,20	49,98	3672	4320	7,05	2317	2317 K
90	160	30	56,06	23,13	4054,5	4770	2,5	1218	1218 K
	160	40	68,80	27,93	4054,5	4770	3,4	2218	2218 K
	190	43	114,66	43,12	3442,5	4050	5,8	1318	1318 K
	190	64	149,94	55,86	3442,5	4050	8,45	2318	2318 K

RODAMIENTOS DE BOLAS A RÓTULA
SELF-ALIGNING RADIAL BALL BEARINGS

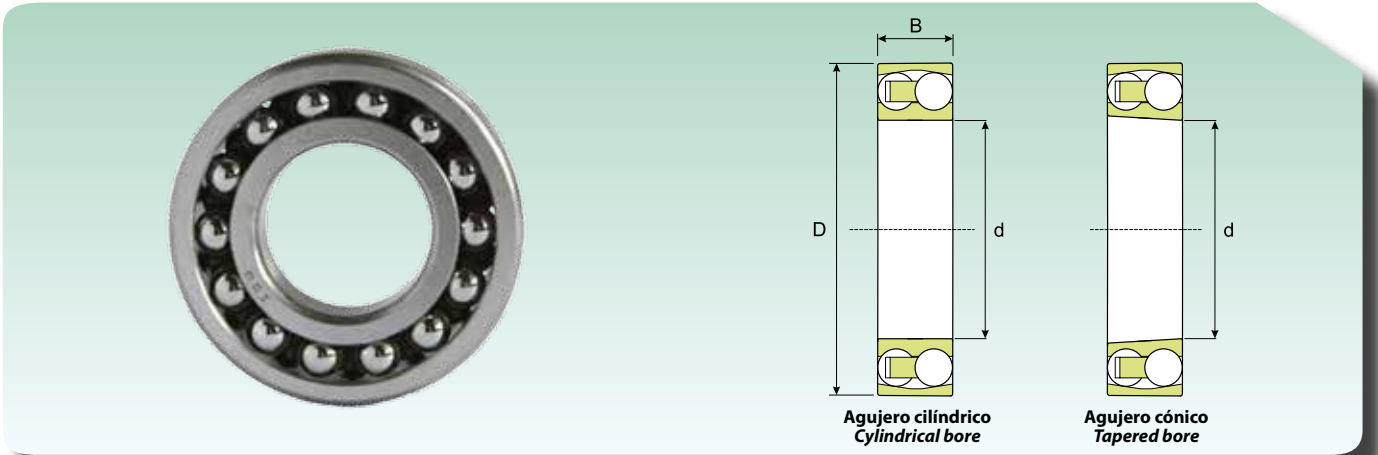

Dimensiones (mm) Dimension (mm)			Coeficiente de carga (KN) Load rating (KN)		Velocidad límite (rpm) Speed limit (Rpm)		Peso (Kg) Weight (Kg)	Sigla Designation	
d (mm)	D (mm)	B (mm)	Dinámico Dynamic C	Estático Static C ₀	Lubrificación Lubrication			Agujero cilíndrico Cylindrical bore	Agujero cónico Tapered bore
					Grasa Grease	Aceite Oil			
95	170	32	62,43	26,46	3825	4500	3,1	1219	1219 K
	170	43	81,54	33,81	3825	4500	4,1	2219	2219 K
	200	45	130,34	49,98	3289,5	3870	6,7	1319	1319 K
	200	67	161,70	62,72	3442,5	4050	9,8	2319	-
100	180	34	67,52	29,40	3672	4320	3,7	1220	1220 K
	180	46	95,55	39,69	3672	4320	5	2220	2220 K
	215	47	140,14	55,86	3060	3600	8,3	1320	1320 K
	215	73	186,20	78,40	3060	3600	12,5	2320	2320 K
110	200	38	86,63	38,22	3289,5	3870	5,15	1222	1222 K
	200	53	121,52	50,96	3289,5	3870	6,5	2222	-
	200	53	121,52	50,96	3289,5	3870	7,1	2222 M	2222-ZZ
	240	50	159,74	70,56	2754	3240	12	1322 M	1322-ZZ
120	215	42	116,62	51,94	3060	3600	6,75	1224 M	1224-ZZ
130	230	46	124,46	57,33	2754	3240	8,3	1226 M	-
150	225	56	56,06	23,13	2601	3060	7,5	1330	-
180	280	74	93,69	39,20	2142	2520	16	1336	-
200	280	60	59,29	28,42	1989	2340	10,7	1340	-
220	300	60	59,29	29,89	1836	2160	11	1344	-
240	320	60	59,29	31,36	1683	1980	11,3	1348	-

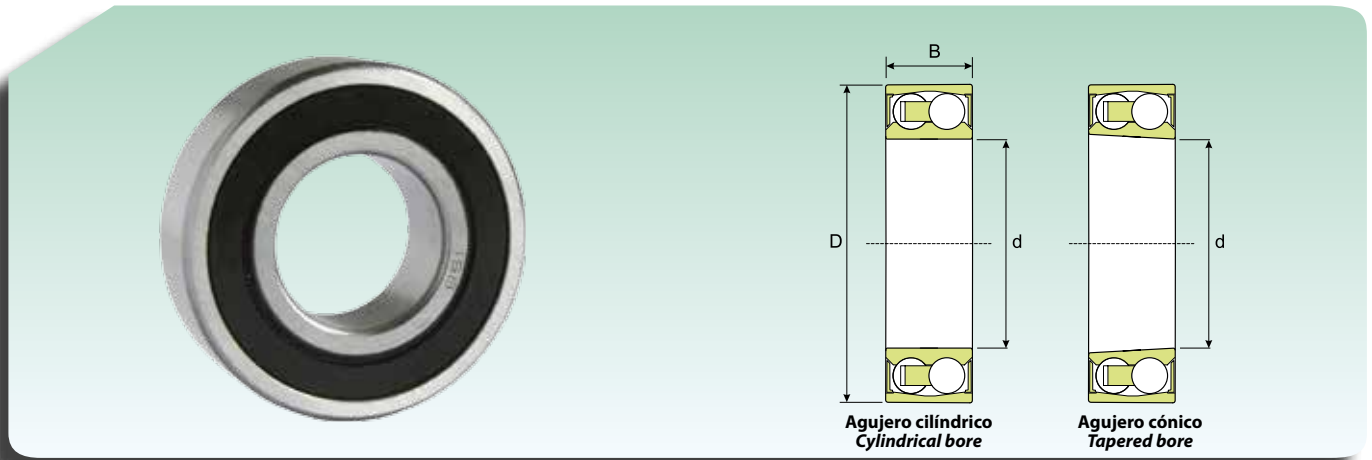
**RODAMIENTOS DE BOLAS A RÓTULA BLINDADOS
SELF-ALIGNING RADIAL BALL BEARINGS - SEALED TYPE**

Dimensiones (mm) Dimension (mm)			Coeficiente de carga (KN) Load rating (KN)		Velocidad límite (rpm) Speed limit (Rpm)	Peso (Kg) Weight (Kg)	Sigla Designation	
d (mm)	D (mm)	B (mm)	Dinámico Dynamic C	Estático Static C ₀			Agujero cilíndrico Cylindrical bore	Agujero cónico Tapered bore
10	30	14	5,42	1,16	16150	0,048	2200-2RSTN9	-
12	32	14	6,12	1,40	15200	0,053	2201-2RSTN9	-
15	35	14	7,26	1,72	13300	0,058	2202-2RSTN9	-
	42	17	10,58	2,55	11400	0,11	2302-2RSTN9	-
17	40	16	8,66	2,16	11400	0,089	2203-2RSTN9	-
	47	19	12,45	3,33	10450	0,16	2303-2RSTN9	-
20	47	18	12,45	3,33	9500	0,14	2204-2RSTN9	-
	52	21	14,01	3,92	8550	0,21	2304-2RSTN9	-
25	52	18	14,01	3,92	8550	0,16	2205-2RSTN9	2205-2RSKTN9
	62	24	18,62	5,29	7125	0,34	2305-2RSTN9	-
30	62	20	15,29	4,56	7125	0,26	2206-2RSTN9	2206-2RSKTN9
	72	27	22,05	6,66	6365	0,51	2306-2RSTN9	-
35	72	23	18,62	5,88	5985	0,41	2207-2RSTN9	2207-2RSKTN9
	80	31	25,97	8,33	5320	0,7	2307-2RSTN9	-
40	80	23	19,50	6,81	5320	0,5	2208-2RSTN9	2208-2RSKTN9
	90	33	33,12	10,98	4750	0,96	2308-2RSTN9	-
45	85	23	22,44	7,64	5035	0,53	2209-2RS1TN9	2209-2RSKTN9
	100	36	38,22	13,13	4275	1,3	2309-2RSTN9	-
50	90	23	22,44	7,99	4560	0,57	2210-2RSTN9	2210-2RSKTN9
	110	40	42,73	13,72	3800	1,65	2310-2RSTN9	-
55	100	25	27,05	10,39	4085	0,79	2211-2RSTN9	2211-2RSKTN9
60	110	28	30,58	11,96	3610	1,05	2212-2RSTN9	2212-2RSKTN9
65	120	31	34,40	13,72	3420	1,4	2213-2RSTN9	2213-2RSKTN9
70	125	31	35,08	14,31	3230	1,45	2214-2RSTN9	-

RODAMIENTOS DE BOLAS A RÓTULA CON ARO INTERIOR MÁS ANCHO
SELF-ALIGNING BALL BEARINGS WITH LARGE INNER RING

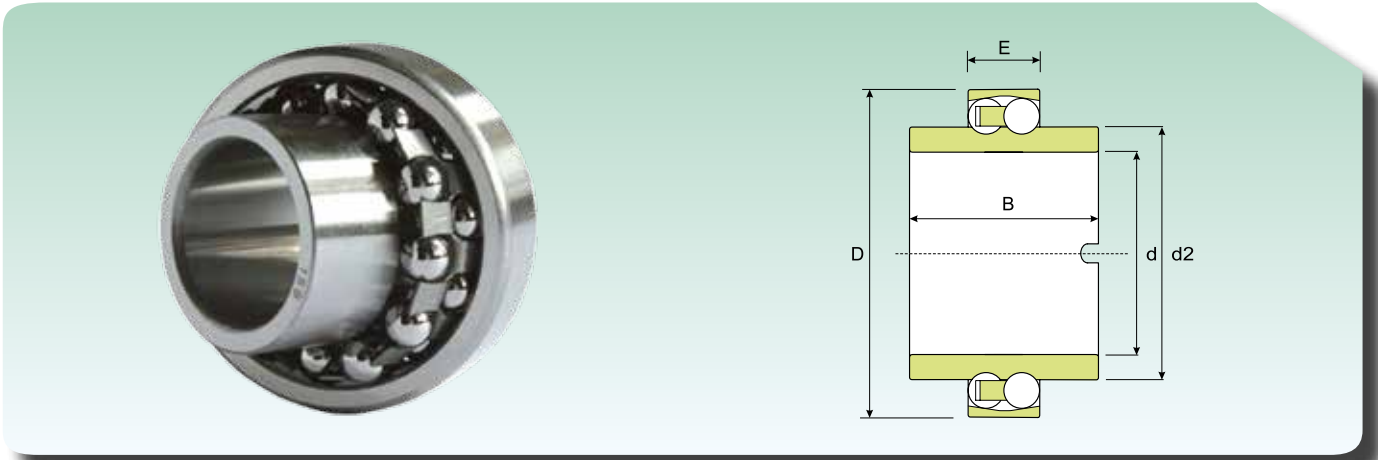

Dimensiones (mm) Dimension (mm)					Coeficiente de carga (KN) Load rating (KN)		Velocidad límite Speed limit	Peso (Kg) Weight (Kg)	Sigla Designation
d (mm)	D (mm)	E (mm)	d2 (mm)	B (mm)	Dinámico Dynamic C	Estático Static C ₀			
20	47	14	28,9	40	12,45	3,33	8550	0,18	11204 TN9
25	52	15	33,3	44	14,01	3,92	7600	0,22	11205 TN9
30	62	16	40,1	48	15,29	4,56	6365	0,35	11206 TN9
35	72	17	47,7	52	15,58	5,00	5320	0,54	11207 TN9
40	80	18	54	56	18,62	6,42	4750	0,72	11208 TN9
45	85	19	57,7	58	21,17	7,20	4275	0,77	11209 TN9
50	90	20	62,7	58	22,44	7,99	4085	0,85	11210 TN9
60	110	22	78	62	29,60	11,37	3230	1,15	11212 TN9

Nota: Bajo demanda puede ser suministrada también la serie 113,,
 Note: The 113 series is available on request

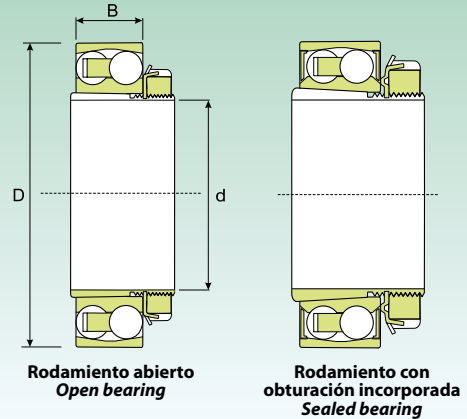
**RODAMIENTOS DE BOLAS A RÓTULA CON MANGUITO DE FIJACIÓN
SELF-ALIGNING BALL BEARINGS WITH ADAPTER SLEEVE**

Dimensiones (mm) <i>Dimension (mm)</i>				Coeficiente de carga (KN) <i>Load rating (KN)</i>		Velocidad límite (rpm) <i>Speed limit (Rpm)</i>		Peso Rodamiento con manguito (Kg) <i>Weight Bearing with adapter (Kg)</i>	Sigla <i>Designation</i>	
d (mm)	D (mm)	B (mm)	B1 (mm)	Dinámico <i>Dynamic C</i>	Estático <i>Static C₀</i>	Lubricación <i>Lubrication</i>			Rodamiento <i>Bearing</i>	Manguito de tracción <i>Adapter sleeve</i>
						Grasa <i>Grease</i>	Aceite <i>Oil</i>			
17	47	14	24	12,4	3,3	15300	18000	0,16	1204 KTN9	H 204
20	52	15	26	14,0	3,9	13770	16200	0,21	1205 KTN9	H 205
	52	18	29	16,5	4,3	13770	16200	0,23	2205 KTN9	H 305
	52	18	29	14,0	3,9	8550	-	0,23	2205-2RS KTN9	H 305
	62	17	29	18,6	5,3	11475	13500	0,33	1305 KTN9	H 305
25	62	16	27	15,3	4,6	11475	13500	0,32	1206 KTN9	H 206
	62	20	31	23,3	6,6	11475	13500	0,36	2206 KTN9	H 306
	62	20	31	15,3	4,6	7125	-	0,36	2206-2RS KTN9	H 306
	72	19	27	22,1	6,7	9945	11700	0,49	1306 KTN9	H 306
	72	27	38	30,6	8,6	9945	11700	0,61	2306 K	H 2306
30	72	17	29	18,6	5,9	9945	11700	0,44	1207 KTN9	H 207
	72	23	35	30,1	8,6	9180	10800	0,54	2207 KTN9	H 307
	72	23	35	18,6	5,9	5985	-	0,55	2207-2RS KTN9	H 307
	80	21	35	26,0	8,3	8415	9900	0,65	1307 KTN9	H 307
	80	31	43	38,9	11,0	9180	10800	0,84	2307 KTN9	H 2307
35	80	18	31	19,5	6,8	8415	9900	0,58	1208 KTN9	H 208
	80	23	36	31,3	9,8	8415	9900	0,58	2208 KTN9	H 308
	80	23	36	19,5	6,8	5320	-	0,67	2208-2RS KTN9	H 308
	90	23	36	33,1	11,0	7268	8550	0,85	1308 KTN9	H 308
	90	33	46	52,9	15,7	7650	9000	1,1	2308 KTN9	H 2308
40	85	19	33	22,4	7,6	8415	9900	0,68	1209 KTN9	H 209
	85	23	39	31,9	10,4	7650	9000	0,78	2209 KTN9	H 309
	85	23	39	22,4	7,6	5035	-	1,2	2209-2RS KTN9	H 309
	100	25	39	38,2	13,1	6503	7650	1,2	1309 KTN9	H 309
	100	36	50	62,4	18,9	6885	8100	1,4	2309 KTN9	H 2309
45	90	20	35	26,0	9,0	7650	9000	0,77	1210 KTN9	H 210
	90	23	42	33,1	11,0	7268	8550	0,87	2210 KTN9	H 310
	90	23	42	22,4	8,0	4560	-	0,84	2210-2RS KTN9	H 310
	110	27	42	42,7	13,7	6120	7200	1,45	1310 KTN9	H 310
	110	40	55	62,4	19,6	7268	8550	1,9	2310 K	H 2310
50	100	21	37	27,0	10,4	6885	8100	0,99	1211 KTN9	H 211
	100	25	45	38,2	13,1	6503	7650	1,15	2211 KTN9	H 311
	100	25	45	27,0	10,4	4085	-	1,1	2211-2RS KTN9	H 311
	120	29	45	49,7	17,6	5738	6750	1,9	1311 KTN9	H 311
	120	43	59	74,6	23,5	5738	6750	2,4	2311 K	H 2311
55	110	22	38	30,6	12,0	6503	7650	1,2	1212 KTN9	H 212
	110	28	47	47,8	16,7	6120	7200	1,4	2212 KTN9	H 312
	110	28	47	30,6	12,0	3610	-	1,4	2212-2RS KTN9	H 312
	130	31	47	57,3	21,6	4820	5670	2,15	1312 KTN9	H 312
	130	46	62	85,4	27,9	5355	6300	2,95	2312 K	H 2312

RODAMIENTOS DE BOLAS A RÓTULA CON MANGUITO DE FIJACIÓN
SELF-ALIGNING BALL BEARINGS WITH ADAPTER SLEEVE

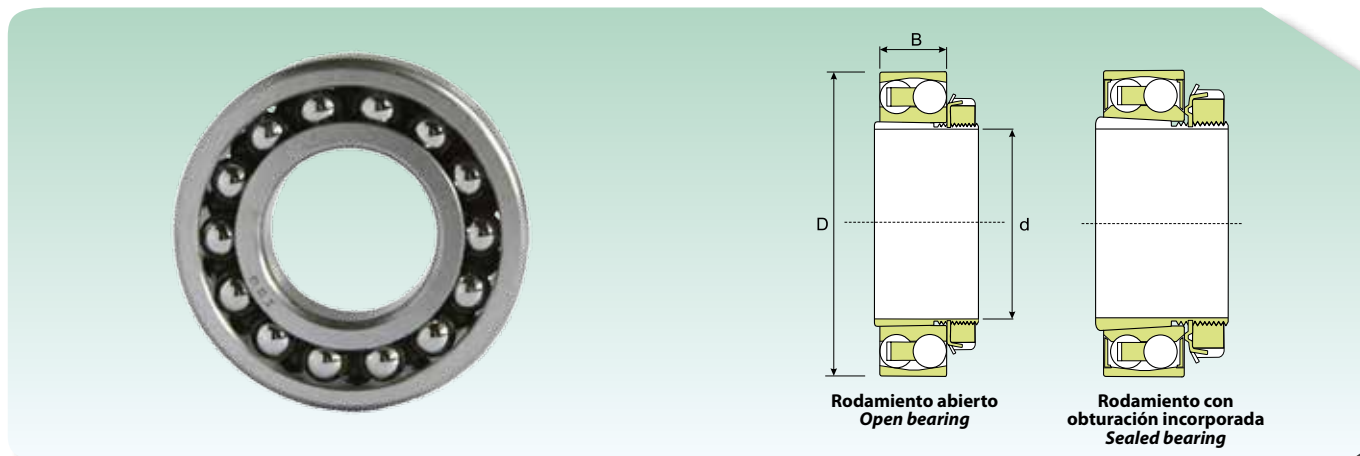

Dimensiones (mm) Dimension (mm)				Coeficiente de carga (KN) Load rating (KN)		Velocidad límite (rpm) Speed limit (Rpm)		Peso Rodamiento con manguito (Kg) Weight Bearing with adapter (Kg)	Sigla Designation	
d (mm)	D (mm)	B (mm)	B1 (mm)	Dinámico Dynamic C	Estático Static C ₀	Lubrificación Lubrication			Rodamiento Bearing	Manguito de tracción Adapter sleeve
						Grasa Grease	Aceite Oil			
60	120	23	40	34,4	13,7	5355	6300	1,45	1213 KTN9	H 213
	120	31	50	56,1	19,6	5355	6300	1,8	2213 KTN9	H 313
	120	31	50	34,4	13,7	3420	-	1,75	2213-2RS KTN9	H 313
	140	33	50	63,7	25,0	4590	5400	2,85	1313 KTN9	H 313
	140	48	65	93,7	31,9	4820	5670	3,6	2313 K	H 2313
65	130	25	43	38,2	15,3	5126	6030	2	1215 K	H 215
	130	31	55	57,3	21,6	4820	5670	2,3	2215 KTN9	H 315
	160	37	55	77,7	29,4	4284	5040	4,2	1315 K	H 315
	160	55	73	121,5	42,1	4284	5040	5,55	2315 K	H 2315
70	140	26	46	38,9	16,7	4590	5400	2,4	1216 K	H 216
	140	33	59	63,7	25,0	4590	5400	2,85	2216 KTN9	H 316
	170	39	59	86,6	32,8	4055	4770	5	1316 K	H 316
	170	58	78	132,3	48,0	4055	4770	7,1	2316 K	H 2316
75	150	28	50	47,8	20,4	4284	5040	2,95	1217 K	H 217
	150	36	63	57,3	23,1	4284	5040	3,3	2217 K	H 317
	180	41	63	95,6	37,2	3672	4320	6	1317 K	H 317
	180	60	82	137,2	50,0	3672	4320	8,15	2317 K	H 2317
80	160	30	52	56,1	23,1	4055	4770	3,5	1218 K	H 218
	160	40	65	68,8	27,9	4055	4770	5,5	2218 K	H 318
	190	43	65	114,7	43,1	3443	4050	6,9	1318 K	H 318
	190	64	86	149,9	55,9	3443	4050	9,8	2318 K	H 2318
85	170	32	55	62,4	26,5	3825	4500	4,25	1219 K	H 219
	170	43	68	81,5	33,8	3825	4500	5,3	2219 K	H 319
	200	45	68	130,3	50,0	3290	3870	7,9	1319 K	H 319
90	180	34	58	67,5	29,4	3672	4320	5	1220 K	H 220
	180	46	71	95,6	39,7	3672	4320	6,4	2220 K	H 320
	215	47	71	140,1	55,9	3060	3600	9,65	1320 K	H 320
	215	73	97	186,2	78,4	3060	3600	14	2320 K	H 2320
100	200	38	63	86,6	38,2	3290	3870	6,8	1222 K	H 222
	200	53	77	121,5	51,0	3290	3870	8,85	2222-ZZ	H 322
	240	50	77	159,7	70,6	2754	3240	13,5	1322-ZZ	H 322
110	215	42	72	116,6	51,9	3060	3600	8,3	1224-ZZ	H 3024





Rodamientos con hilera simple de rodillos cilíndricos

Cylindrical roller bearings, single row



RODAMIENTOS DE UNA HILERA DE RODILLOS CILÍNDRICOS

Los rodamientos **ISB**[®] de una hilera de rodillos cilíndricos (**Fig.1**) se fabrican en una amplia gama de versiones diferentes y son siempre desarmables, en modo tal de facilitar su montaje. Los rodamientos y los rodillos logran soportar elevadas cargas radiales y alcanzar elevadas velocidades. Los rodillos y la respectiva jaula pueden estar guiados por el aro interior o por el exterior; de los dos aros que componen el rodamiento, el que guía los rodillos cuenta con pestañas, el segundo no tiene pestañas y es desmontable. La particularidad que diferencia las variantes de rodamientos de rodillos cilíndricos es el tipo de pestaña. A continuación se exponen los diseños más comunes.

SINGLE ROW CYLINDRICAL ROLLER BEARINGS

ISB[®] single row cylindrical roller bearings (**Fig.1**) are manufactured in a wide range of different versions and are always separable to facilitate assembly. Roller bearings are able to withstand high radial loads and to reach high speeds. The rollers and respective cage can be guided by the inner ring or by the outer ring; out of the two rings that make up the bearing, the one that guides the roller is flanged, the second ring is not flanged and can be extracted. What differentiates the variants of cylindrical roller bearings is the type of flange. Here are the most common versions.

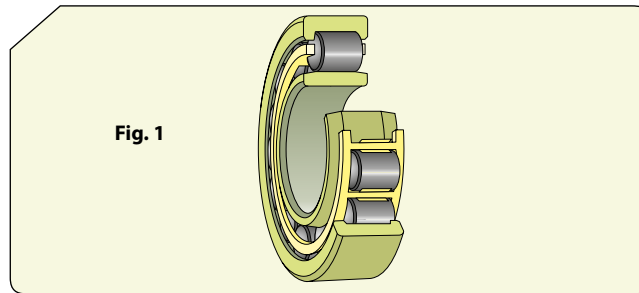

DISEÑO NU

El aro exterior de los rodamientos tiene dos pestañas integrales, mientras que el aro interior no lleva pestañas. El desplazamiento axial del eje respecto al alojamiento se verifica dentro del rodamiento en ambos sentidos. (**Fig. 2**).

NU VERSION

Outer ring with two integral flanges, inner ring without flanges. Axial displacement of the shaft compared to the housing can be accommodated inside the bearing in both directions (**Fig. 2**).

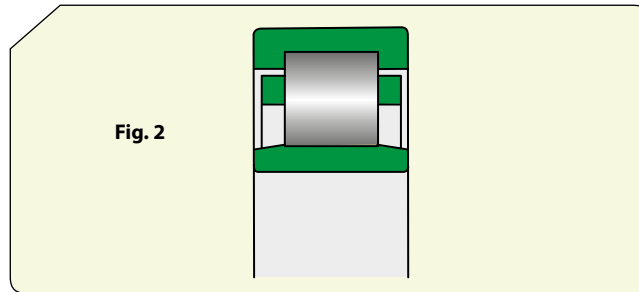

DISEÑO N

El aro interior tiene dos pestañas integrales, mientras que el aro exterior no lleva pestañas. El desplazamiento axial del eje respecto al alojamiento se verifica dentro del rodamiento en ambos sentidos. (**Fig. 3**).

N VERSION

Inner ring with two integral flanges, outer ring without flanges. Axial displacement of the shaft compared to the housing can be accommodated inside the bearing in both directions (**Fig. 3**).

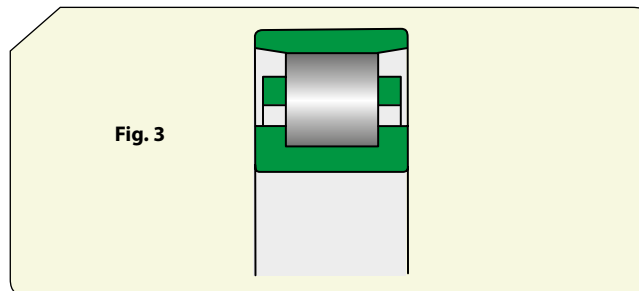

DISEÑO NJ

El aro exterior tiene dos pestañas integrales, mientras que el aro interior tiene una sola. El eje está vinculado axialmente en una dirección (Fig. 4).

NJ VERSION

Outer ring with two integral flanges, inner ring with just one flange. The shaft is bound axially in one direction (Fig. 4).

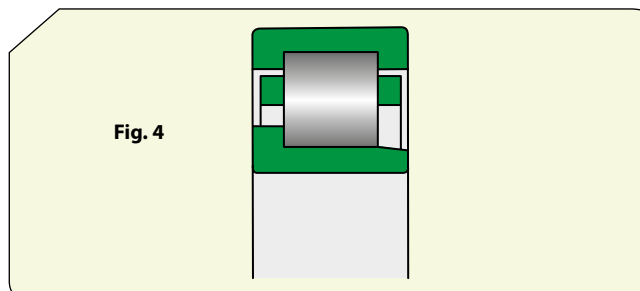

DISEÑO NUP

El aro exterior tiene dos pestañas integrales, mientras que el aro interior tiene una pestaña integral y una no integral. El eje está vinculado axialmente en ambas direcciones (Fig. 5).

NUP VERSION

Outer ring with two integral flanges, inner ring with one integral flange and one added non-integral flange. The shaft is bound axially in both directions (Fig. 5).

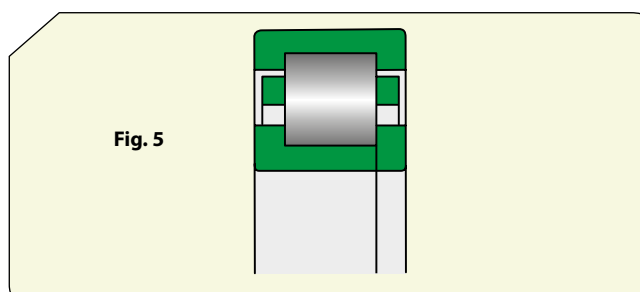

AROS ANGULARES

Los aros angulares, con la designación de serie HJ, han sido diseñados para estabilizar axialmente los rodamientos ISB® de rodillos cilíndricos. Están templados y rectificados, el desplazamiento lateral máximo permitido está dentro de las tolerancias Normales de los respectivos rodamientos. El listado de todas las dimensiones y designaciones de los aros angulares aparecen en las tablas productos junto al respectivo rodamiento.

ANGLE RINGS

Their series designation is HJ and they are designed to stabilise ISB® cylindrical roller bearings in the axial direction. They are hardened and ground and the maximum admitted side face runout is within the Normal tolerances of the relative bearings. The list of all the sizes and designations of the angle rings is given in the product table matched with relative bearing.

DISEÑO NU + AROS ANGULARES HJ

Combinación utilizada para vincular axialmente el eje en una dirección. Se recomienda de no utilizar los aros angulares HJ de ambos lados del rodamiento, ya que esto podría bloquear los rodillos axialmente (Fig. 6).

NU VERSION + HJ ANGLE RING

This combination is used to axially bind the shaft in one direction. It is not recommended to use HJ angle rings on both sides of the bearing because it could block the rollers axially (Fig. 6).

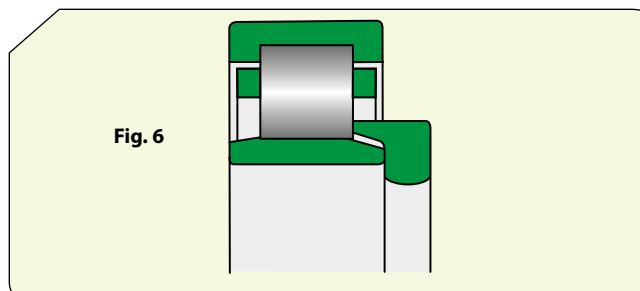

DISEÑO NJ + AROS ANGULARES HJ

Combinación utilizada para vincular el eje en las dos direcciones (Fig. 7).

NJ VERSION + HJ ANGLE RING

This combination is used to bind the shaft in both directions (Fig. 7).

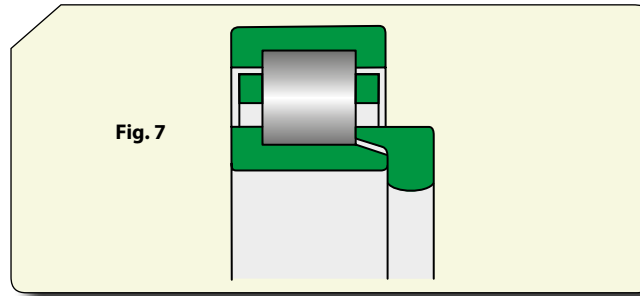
Fig. 7
RODAMIENTOS CON AGUJERO CÓNICO

Generalmente los rodamientos **ISB**[®] de rodillos cilíndricos se fabrican con agujero cilíndrico. De todos modos pueden suministrarse con agujero cónico 1:12 (**Fig. 8**), identificados por el sufijo K en la designación y el juego radial interior es más grande respecto al del agujero cilíndrico. Contactar la oficina técnica de las aplicaciones **ISB**[®] para verificar la disponibilidad.

BEARINGS WITH TAPERED BORE

ISB[®] cylindrical roller bearings are normally produced with a cylindrical bore. Despite this however, some also have a tapered bore 1:12, which have designation suffix K and the internal radial clearance is larger than that with cylindrical bore. Contact the **ISB**[®] applications engineering department to check availability.

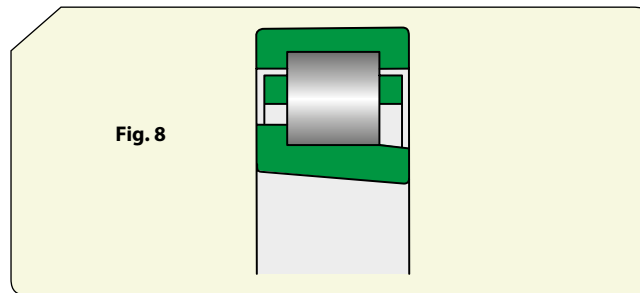
Fig. 8
RODAMIENTOS CON RANURA PARA ARO DE FIJACIÓN

Identificados por el sufijo N en la designación son un tipo particular de rodamiento fabricado con un ranurado para aro de fijación en el aro externo (**Fig. 9**). Contactar la oficina técnica de las aplicaciones **ISB**[®] para verificar la disponibilidad.

BEARINGS WITH A SNAP RING GROOVE

Identified by designation suffix N, they are a special type of bearing produced with a groove for the snap ring on the outer ring (**Fig. 9**). Contact the **ISB**[®] applications engineering department to check availability.

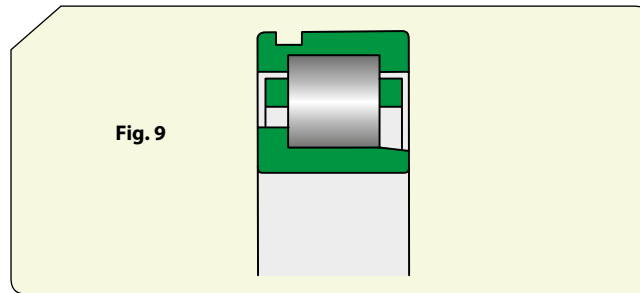
Fig. 9
DIMENSIONES

Las dimensiones de los rodamientos **ISB**[®] de una hilera de rodillos cilíndricos respetan la norma ISO 15:1998.

Las dimensiones de los anillos de resalte HJ corresponden a las especificadas en la norma ISO 246:1995.

DIMENSIONS

The dimensions of **ISB**[®] single row cylindrical roller bearings comply with standard ISO 15:1998.

The dimensions of the angle rings HJ match those specified in standard ISO 246:1995.

TOLERANCIAS

Los rodamientos **ISB**[®] de una hilera de rodillos cilíndricos se fabrican con tolerancias Normales, especificadas en la norma ISO 492:2002.

TOLERANCES

ISB[®] single row cylindrical roller bearings are usually manufactured with the Normal tolerances specified in standard ISO 492:2002.

JUEGO INTERNO RADIAL

Además del juego interior radial normal, muchas versiones de los rodamientos **ISB**[®] de una hilera de rodillos cilíndricos se fabrican con un juego menor (C2), mayor (C3) o mucho mayor (C4). Todos los componentes de los rodamientos **ISB**[®] de rodillos cilíndricos son desarmables.

INTERNAL RADIAL CLEARANCE

Together with the Normal internal radial clearance, many versions of **ISB**[®] single row cylindrical roller bearings are also available with smaller clearance (C2), greater clearance (C3) or much greater clearance (C4). All the components of **ISB**[®] single row cylindrical roller bearings are separable.

DESALINEACIÓN

En este tipo específico de rodamiento la tolerancia de las desalineaciones que se pueden verificar está limitada a pocos décimos de milímetro. Desalineaciones mayores abrevian la durabilidad del rodamiento.

DESPLAZAMIENTO AXIAL

El desplazamiento axial del eje respecto al alojamiento, causado por dilatación térmica, está compensado por los rodamientos **ISB**[®] de una hilera de rodillos cilíndricos de la serie NJ, N, NUP. Durante la rotación del rodamiento no se verifica aumento de fricción porque el desplazamiento axial se produce dentro del rodamiento.

TEMPERATURA DE FUNCIONAMIENTO

Sometiéndolos a especiales tratamientos térmicos, equipados con jaula de acero o de latón, pueden ser empleados a temperaturas de hasta + 150°C. Si está prevista una jaula de poliamida 6.6 la temperatura máxima de servicio podrá alcanzar los + 120°C

JAULAS

A continuación se enumeran las jaulas con las que están equipados los rodamientos **ISB**[®] de una hilera de rodillos cilíndricos:

- Moldeada por inyección, con ventanas, en poliamida 6.6 reforzada con fibra de vidrio (**Fig. 10a**);
- Moldeada, con ventanas, en chapa de acero no templado (**Fig. 10b**);
- Monobloque, mecanizada de latón (**Fig. 10c**);
- Mecanizada de latón en dos partes, centrada en los rodillos (**Fig. 10d**).

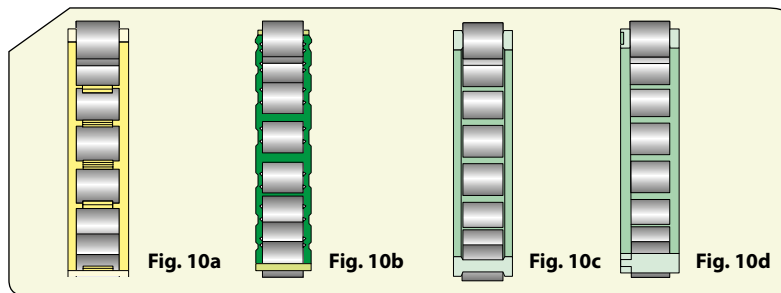

CARGA MÍNIMA

Para que esté garantizado un rendimiento satisfactorio, los rodamientos **ISB**[®] de una hilera de rodillos cilíndricos deben siempre estar sujetos a una carga mínima. En caso de utilización a altas velocidades, con fuertes aceleraciones o repentinos cambios de dirección de la carga, las fuerzas de inercia de los rodillos de la jaula y la fricción del lubricante, pueden provocar deslizamientos perjudiciales entre las bolas y los caminos de rodadura.

CAPACIDAD DE CARGA DINÁMICA AXIAL

Los rodamientos **ISB**[®] de una hilera de rodillos cilíndricos con pestañas en ambos aros pueden soportar también cargas axiales además de las cargas radiales. Esta resistencia a las cargas axiales depende de la lubricación, la temperatura de utilización y la disipación del calor del rodamiento.

MISALIGNMENT

In this specific type of bearing, the tolerance of misalignments that may occur is rather limited (a few arc minutes). Greater misalignments reduce the bearing's life span.

AXIAL DISPLACEMENT

*The axial displacement of the shaft compared to the housing, caused by thermal expansion, is compensated by **ISB**[®] single row cylindrical roller bearings of series NJ, N, NUP. During rotation of the bearing, there is no increase in friction because the axial displacement occurs within the bearing.*

OPERATING TEMPERATURE

They are put through special heat treatments. When equipped with steel or brass cage, they can be used at temperatures up to + 150°C. When equipped with cage made of polyamide 6.6, the maximum operating temperature is + 120°C

CAGES

*Here's a list of the cages with which **ISB**[®] single row cylindrical roller bearings are equipped:*

- *Injection moulded window-type cage made of polyamide 6.6 with fibreglass reinforcement (**Fig. 10a**);*
- *Pressed window-type cage made of unhardened sheet steel (**Fig. 10b**);*
- *Solid single-piece machined brass cage (**Fig. 10c**);*
- *Solid two-piece machined brass cage, centred on the rollers (**Fig. 10d**);*

MINIMUM LOAD

*In order to ensure a satisfactory performance, **ISB**[®] single row cylindrical roller bearings must always be subjected to a given minimum load. If they are to be used at high speeds, strong accelerations or sudden changes in directions of the load, the inertia forces of the rollers of the cage and the friction of the lubricant may cause harmful contacts between the rollers and raceways.*

DYNAMIC AXIAL LOAD CARRYING CAPACITY

***ISB**[®] single row cylindrical roller bearings with flanges on both rings may take greater axial loads in addition to radial loads. This axial load carrying capacity mainly depends on lubrication, operating temperature and dissipation of the bearing's heat.*

DESIGNACIONES SUPLEMENTARIAS

C2	Juego interno radial inferior al Normal
C3	Juego interno radial mayor que el Normal
C4	Juego interno radial mayor que C3
J	Jaula moldeada de chapa de acero
K	Agujero conico, conicidad 1:12
M	Jaula mecanizada de latón, en dos partes, centrada en los rodillos
MA	Jaula mecanizada de latón en dos partes, centrada en el aro exterior
MB	Jaula mecanizada de latón en dos partes centrada en el aro interior
N	Ranurado para aro de fijación en el diámetro exterior del aro exterior
NR	Ranurado e idóneo aro de fijación en el aro externo
P	Jaula moldeada por inyección, en poliamida 6.6. reforzada con fibra de vidrio
W33	Ranura anular y tres agujeros de lubricación en el aro exterior
K30	Agujero conico, conicidad 1:30
TN9	Jaula moldeada por inyección, de montaje a presión, en poliamida 6.6 reforzada con fibras de vidrio centrada en las bolas

SUPPLEMENTARY DESIGNATIONS

C2	<i>Internal radial clearance smaller than Normal</i>
C3	<i>Internal radial clearance greater than Normal</i>
C4	<i>Internal radial clearance greater than C3</i>
J	<i>Pressed steel cage</i>
K	<i>Tapered bore, taper 1:12</i>
M	<i>Solid two-piece machined brass cage, centred on the rollers</i>
MA	<i>Solid two-piece machined brass cage centered on the outer ring</i>
MB	<i>Solid two-piece machined brass cage centered on the inner ring</i>
N	<i>Groove for snap ring in outside diameter of outer ring</i>
NR	<i>Groove and snap ring on outer ring</i>
P	<i>Injection moulded cage made of polyamide 6.6 with fibreglass reinforcement</i>
W33	<i>Circumferential groove and three lubrication holes in outer ring</i>
K30	<i>Tapered bore, taper 1:30</i>
TN9	<i>Shield made of pressed sheet steel on both sides of the bearing</i>

RODAMIENTOS DE UNA HILERA DE RODILLOS CILÍNDRICOS
CYLINDRICAL ROLLER BEARINGS, SINGLE ROW

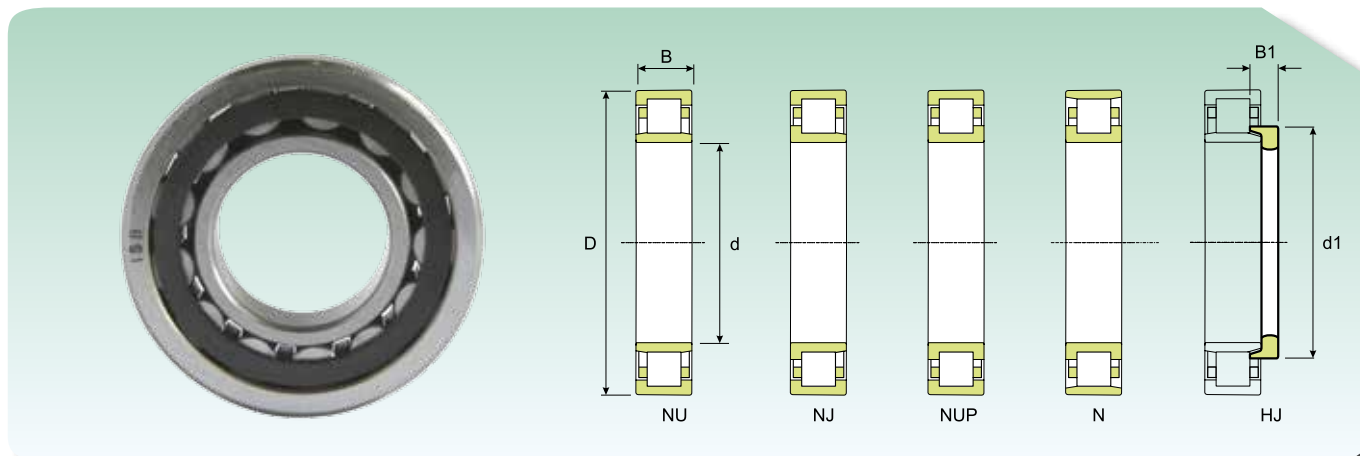

Dimensiones (mm) Dimension (mm)					Coeficiente de carga (kN) Load rating (kN)		Velocidad límite (rpm) Speed limit (Rpm)		Peso (Kg) Weight (Kg)	Sigla Designation	Aro angular Thrust collar
d (mm)	D (mm)	B (mm)	d1 (mm)	B1 (mm)	Dinámico Dynamic C	Estático Static C ₀	Lubricación Lubrication				
							Grasa Grease	Aceite Oil			
15	35	11	-	-	12	10	19890	23400	0.047	NU 202	-
	35	11	21.9	-	12	10	19890	23400	0.049	NJ 202	-
17	40	12	25	-	17	14	16830	19800	0.066	N 203	-
	40	12	25	-	17	14	16830	19800	0.07	NJ 203	-
	40	12	-	-	17	14	16830	19800	0.068	NU 203	-
	40	12	25	-	17	14	16830	19800	0.073	NUP 203	-
	40	16	25	-	23	21	16830	19800	0.095	NJ 2203	-
	40	16	-	-	23	21	16830	19800	0.092	NU 2203	-
	40	16	25	-	23	21	16830	19800	0.097	NUP 2203	-
	47	14	27.7	-	24	20	15300	18000	0.12	N 303	-
	47	14	27.7	-	24	20	15300	18000	0.12	NJ 303	-
	47	14	-	-	24	20	15300	18000	0.12	NU 303	-
20	47	14	29.7	-	25	22	14535	17100	0.11	N 204	-
	47	14	29.7	-	25	22	14535	17100	0.11	NJ 204	-
	47	14	-	-	25	22	14535	17100	0.11	NU 204	-
	47	14	29.7	-	25	22	14535	17100	0.12	NUP 204	-
	47	18	29.7	-	29	27	14535	17100	0.14	NJ 2204	-
	47	18	-	-	29	27	14535	17100	0.14	NU 2204	-
	52	15	31.2	-	35	25	13770	16200	0.15	N 304	-
	52	15	31.2	6.5	35	25	13770	16200	0.17	NJ 304	HJ 304
	52	15	31.2	6.5	35	25	13770	16200	0.17	NU 304	HJ304
	52	15	31.2	-	35	25	13770	16200	0.16	NUP 304	-
	52	21	31.2	-	47	37	13770	16200	0.22	NJ 2304	-
	52	21	-	-	47	37	13770	16200	0.21	NU 2304	-
	52	21	31.2	-	47	37	13770	16200	0.22	NUP 2304	-
	25	47	12	-	-	14	13	13770	16200	0.084	NU 1005
52		15	34.7	-	28	26	12240	14400	0.13	N 205	-
52		15	34.7	6	28	26	12240	14400	0.15	NJ 205	HJ 205
52		15	34.7	6	28	26	12240	14400	0.14	NU 205	HJ 205
52		15	34.7	-	28	26	12240	14400	0.14	NUP 205	-
52		18	34.7	6.5	33	33	12240	14400	0.18	NJ 2205	HJ 2205
52		18	34.7	6.5	33	33	12240	14400	0.17	NU 2205	HJ 2205
52		18	34.7	-	33	33	12240	14400	0.17	NUP 2205	-
62		17	38.1	-	46	36	11475	13500	0.24	N 305	-
62		17	38.1	7	46	36	11475	13500	0.29	NJ 305	HJ 305
62		17	38.1	7	46	36	11475	13500	0.28	NU 305	HJ 305
62		17	38.1	-	46	36	11475	13500	0.25	NUP 305	-
62		24	38.1	8	63	54	11475	13500	0.39	NJ 2305	HJ 2305
62		24	38.1	8	63	54	11475	13500	0.38	NU 2305	HJ 2305
62		24	38.1	-	63	54	11475	13500	0.38	NUP 2305	-
30		55	13	-	-	18	17	11475	13500	0.12	NU 1006
	62	16	41.2	-	43	36	10710	12600	0.2	N 206	-
	62	16	41.2	7	43	36	10710	12600	0.24	NJ 206	HJ 206
	62	16	41.2	7	43	36	10710	12600	0.23	NU 206	HJ 206
	62	16	41.2	-	43	36	10710	12600	0.22	NUP 206	-
	62	20	41.2	-	54	48	10710	12600	0.27	NJ 2206	-

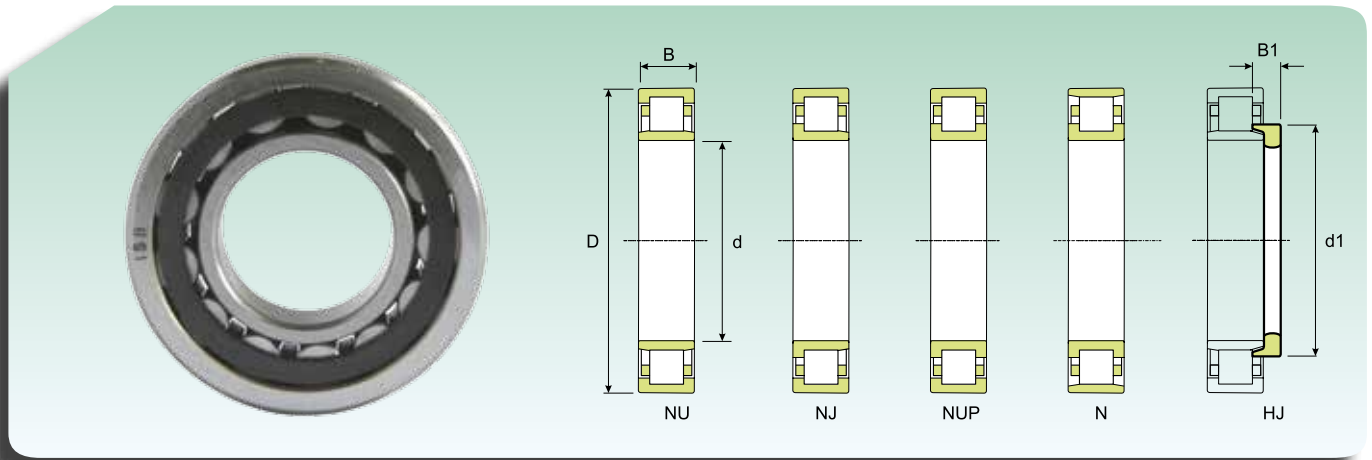
**RODAMIENTOS DE UNA HILERA DE RODILLOS CILÍNDRICOS
CYLINDRICAL ROLLER BEARINGS, SINGLE ROW**

Dimensiones (mm) Dimension (mm)					Coeficiente de carga (KN) Load rating (KN)		Velocidad límite (rpm) Speed limit (Rpm)		Peso (Kg) Weight (Kg)	Sigla Designation	Aro angular Thrust collar
d (mm)	D (mm)	B (mm)	d1 (mm)	B1 (mm)	Dinámico Dynamic C	Estático Static C ₀	Lubrificación Lubrication				
							Grasa Grease	Aceite Oil			
30	62	20	-	-	54	48	10710	12600	0.26	NU 2206	-
	62	20	41.2	-	54	48	10710	12600	0.27	NUP 2206	-
	72	19	45	-	57	47	9180	10800	0.36	N 306	-
	72	19	45	8.5	57	47	9180	10800	0.41	NJ 306	HJ 306
	72	19	45	8.5	57	47	9180	10800	0.4	NU 306	HJ 306
	72	19	45	-	57	47	9180	10800	0.38	NUP 306	-
	72	27	45	-	81	74	9180	10800	0.54	NJ 2306	-
	72	27	-	-	81	74	9180	10800	0.53	NU 2306	-
	72	27	45	-	81	74	9180	10800	0.55	NUP 2306	-
	90	23	50.5	11.5	59	52	8415	9900	0.77	NJ 406	HJ 406
	90	23	50.5	11.5	59	52	8415	9900	0.75	NU 406	HJ 406
	35	62	14	-	-	35	37	9945	11700	0.16	NU 1007
72		17	48.1	-	55	47	9180	10800	0.3	N 207	-
72		17	48.1	7	55	47	9180	10800	0.31	NJ 207	HJ 207
72		17	48.1	7	55	47	9180	10800	0.3	NU 207	HJ 207
72		17	48.1	-	55	47	9180	10800	0.32	NUP 207	-
72		23	48.1	-	68	62	9180	10800	0.41	NJ 2207	-
72		23	-	-	68	62	9180	10800	0.4	NU 2207	-
72		23	48.1	-	68	62	9180	10800	0.42	NUP 2207	-
80		21	51	-	74	62	8415	9900	0.48	N 307	-
80		21	51	9.5	74	62	8415	9900	0.55	NJ 307	HJ 307
80		21	51	9.5	74	62	8415	9900	0.54	NU 307	HJ 307
80		21	51	-	74	62	8415	9900	0.51	NUP 307	-
80		31	51	-	104	96	8415	9900	0.73	NJ 2307	-
80		31	-	-	104	96	8415	9900	0.72	NU 2307	-
80		31	51	-	104	96	8415	9900	0.75	NUP 2307	-
100		25	59	-	75	68	7268	8550	1.05	NJ 407	-
100		25	-	-	75	68	7268	8550	1	NU 407	-
40		68	15	-	-	25	25	13770	16200	0.22	NU 1008
	80	18	54	-	61	52	8415	9900	0.37	N 208	-
	80	18	54	8.5	61	52	8415	9900	0.43	NJ 208	HJ 208
	80	18	54	8.5	61	52	8415	9900	0.42	NU 208	HJ 208
	80	18	54	-	61	52	8415	9900	0.4	NUP 208	-
	80	23	54	9	80	74	8415	9900	0.55	NJ 2208	HJ 2208
	80	23	54	9	80	74	8415	9900	0.54	NU 2208	HJ 2208
	80	23	54	-	80	74	8415	9900	0.56	NUP 2208	-
	90	23	57.5	-	91	76	7268	8550	0.64	N 308	-
	90	23	57.5	11	91	76	7268	8550	0.75	NJ 308	HJ 308
	90	23	57.5	11	91	76	7268	8550	0.73	NU 308	HJ 308
	90	23	57.5	-	91	76	7268	8550	0.68	NUP 308	-
	90	33	57.5	-	126	118	7268	8550	0.96	NJ 2308	-
	90	33	-	-	126	118	7268	8550	0.94	NU 2308	-
	90	33	57.5	-	126	118	7268	8550	0.98	NUP 2308	-
	110	27	64.8	-	95	88	6503	7650	1.35	NJ 408	-
	110	27	-	-	95	88	6503	7650	1.3	NU 408	-

RODAMIENTOS DE UNA HILERA DE RODILLOS CILÍNDRICOS
CYLINDRICAL ROLLER BEARINGS, SINGLE ROW

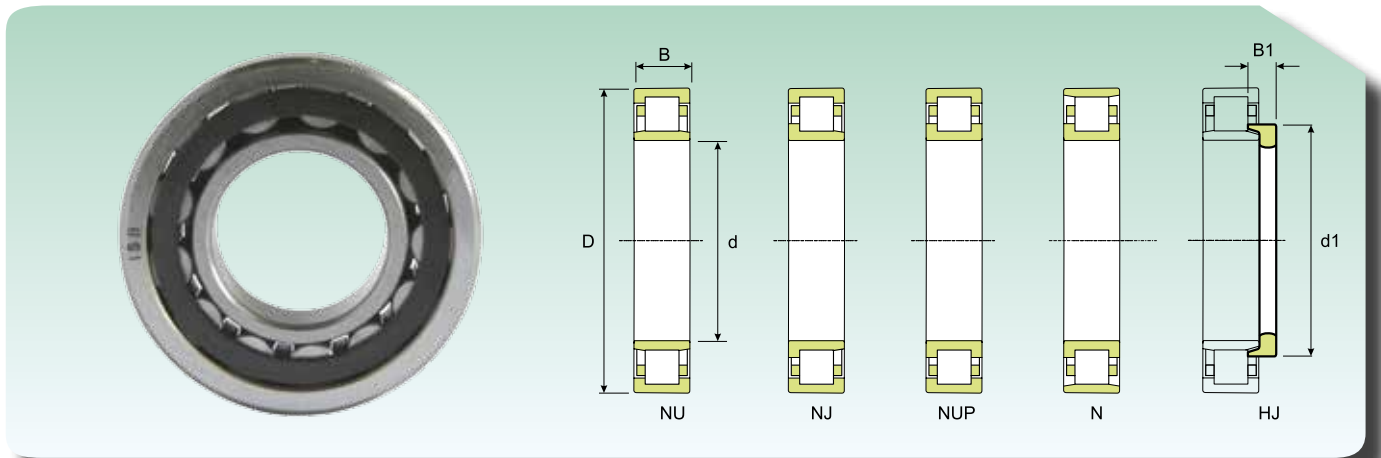

Dimensiones (mm) Dimension (mm)					Coeficiente de carga (KN) Load rating (KN)		Velocidad límite (rpm) Speed limit (Rpm)		Peso (Kg) Weight (Kg)	Sigla Designation	Aro angular Thrust collar
d (mm)	D (mm)	B (mm)	d1 (mm)	B1 (mm)	Dinámico Dynamic C	Estático Static C ₀	Lubricación Lubrication				
							Grasa Grease	Aceite Oil			
45	75	16	-	-	44	51	8415	9900	0.26	NU 1009	-
	85	19	59	-	68	63	7268	8550	0.43	N 209	-
	85	19	59	8.5	68	63	7268	8550	0.49	NJ 209	HJ 209
	85	19	59	8.5	68	63	7268	8550	0.48	NU 209	HJ 209
	85	19	59	-	68	63	7268	8550	0.45	NUP 209	-
	85	23	59	-	83	80	7268	8550	0.54	NJ 2209	-
	85	23	-	-	83	80	7268	8550	0.52	NU 2209	-
	85	23	59	-	83	80	7268	8550	0.55	NUP 2209	-
	100	25	64.4	-	110	98	6503	7650	0.88	N 309	-
	100	25	64.4	11.5	110	98	6503	7650	1.05	NJ 309	HJ 309
	100	25	64.4	11.5	110	98	6503	7650	1	NU 309	HJ 309
	100	25	64.4	-	110	98	6503	7650	0.95	NUP 309	-
	100	36	64.4	-	157	150	6503	7650	1.35	NJ 2309	-
	100	36	-	-	157	150	6503	7650	1.3	NU 2309	-
	100	36	64.4	-	157	150	6503	7650	1.35	NUP 2309	-
	120	29	71.8	13.5	104	100	5738	6750	1.7	NJ 409	HJ 409
120	29	71.8	13.5	104	100	5738	6750	1.65	NU 409	HJ 409	
50	80	16	-	-	46	55	7268	8550	0.35	NU 1010	-
	90	20	64	-	72	68	6885	8100	0.48	N 210	-
	90	20	64	9	72	68	6885	8100	0.5	NJ 210	HJ 210
	90	20	64	9	72	68	6885	8100	0.49	NU 210	HJ 210
	90	20	64	-	72	68	6885	8100	0.51	NUP 210	-
	90	23	64	-	88	86	6885	8100	0.59	NJ 2210	-
	90	23	-	-	88	86	6885	8100	0.56	NU 2210	-
	90	23	64	-	88	86	6885	8100	0.59	NUP 2210	-
	110	27	71.2	-	124	110	6120	7200	1.15	N 310	-
	110	27	71.2	13	124	110	6120	7200	1.15	NJ 310	HJ 310
	110	27	71.2	13	124	110	6120	7200	1.15	NU 310	HJ 310
	110	27	71.2	-	124	110	6120	7200	1.2	NUP 310	-
	110	40	71.2	-	182	182	6120	7200	1.75	NJ 2310	-
	110	40	-	-	182	182	6120	7200	1.7	NU 2310	-
	110	40	71.2	-	182	182	6120	7200	1.8	NUP 2310	-
	130	31	78.8	14.5	127	124	5355	6300	2.05	NJ 410	HJ 410
130	31	78.8	14.5	127	124	5355	6300	2	NU 410	HJ 410	
55	90	18	-	-	56	68	6503	7650	0.4	NU 1011	-
	100	25	70.8	-	112	116	6120	7200	0.82	NUP 2211	-
	100	21	70.8	-	95	93	6120	7200	0.66	N 211	-
	100	21	70.8	9.5	95	93	6120	7200	0.67	NJ 211	HJ 211
	100	21	70.8	9.5	95	93	6120	7200	0.67	NU 211	HJ 211
	100	21	70.8	-	95	93	6120	7200	0.69	NUP 211	-
	100	25	70.8	10	112	116	6120	7200	0.81	NJ 2211	HJ 2211
	100	25	70.8	10	112	116	6120	7200	0.79	NU 2211	HJ 2211
	120	29	77.5	-	153	140	5355	6300	1.45	N 311	-
	120	29	77.5	9	153	140	5355	6300	1.5	NJ 311	HJ 311
	120	29	77.5	9	153	140	5355	6300	1.45	NU 311	HJ 311
	120	29	77.5	-	153	140	5355	6300	1.55	NUP 311	-
	120	43	77.5	9	227	227	5355	6300	2.3	NJ 2311	HJ 2311

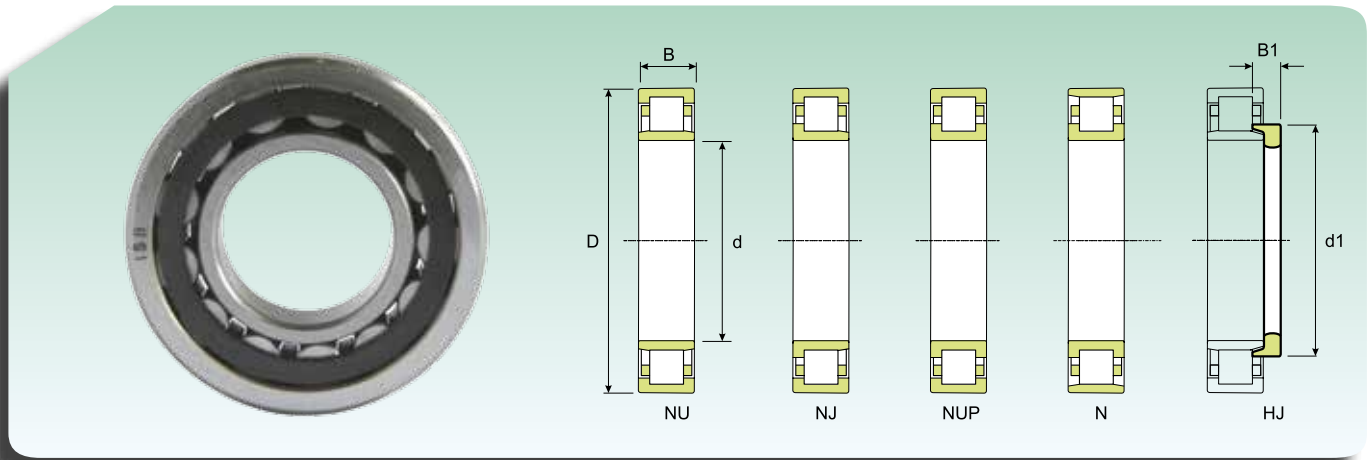
**RODAMIENTOS DE UNA HILERA DE RODILLOS CILÍNDRICOS
CYLINDRICAL ROLLER BEARINGS, SINGLE ROW**

Dimensiones (mm) Dimension (mm)					Coeficiente de carga (kN) Load rating (kN)		Velocidad límite (rpm) Speed limit (Rpm)		Peso (Kg) Weight (Kg)	Sigla Designation	Aro angular Thrust collar
d (mm)	D (mm)	B (mm)	d1 (mm)	B1 (mm)	Dinámico Dynamic C	Estático Static C ₀	Lubricación Lubrication				
							Grasa Grease	Aceite Oil			
55	120	43	77.5	9	227	227	5355	6300	2.25	NU 2311	HJ 2311
	120	43	77.5	-	227	227	5355	6300	2.35	NUP 2311	-
	140	33	85.2	-	139	137	4820	5670	2.55	NJ 411	-
	140	33	85.2	-	139	137	4820	5670	2.5	NU 411	-
60	95	18	-	-	37	43	9945	11700	0.48	NU 1012	-
	110	22	77.5	-	106	100	5738	6750	0.81	N 212	-
	110	22	77.5	10	106	100	5738	6750	0.83	NJ 212	HJ 212
	110	22	77.5	10	106	100	5738	6750	0.81	NU 212	HJ 212
	110	22	77.5	-	106	100	5738	6750	0.86	NUP 212	-
	110	28	77.5	10	143	150	5738	6750	1.15	NJ 2212	HJ 2212
	110	28	77.5	10	143	150	5738	6750	1.1	NU 2212	HJ 2212
	110	28	77.5	-	143	150	5738	6750	1.15	NUP 2212	-
	130	31	84.3	-	170	157	5126	6030	1.8	N 312	-
	130	31	84.3	14.5	170	157	5126	6030	1.9	NJ 312	HJ 312
	130	31	84.3	14.5	170	157	5126	6030	1.8	NU 312	HJ 312
	130	31	84.3	-	170	157	5126	6030	1.95	NUP 312	-
	130	46	84.3	16	255	260	5126	6030	2.8	NJ 2312	HJ 2312
	130	46	84.3	16	255	260	5126	6030	2.75	NU 2312	HJ 2312
	130	46	84.3	-	255	260	5126	6030	2.85	NUP 2312	-
	150	35	91.8	-	165	170	4590	5400	3.1	NJ 412	-
150	35	-	-	165	170	4590	5400	3	NU 412	-	
65	100	18	-	-	61	80	5738	6750	0.45	NU 1013	-
	120	23	84.4	-	120	116	5126	6030	1.05	N 213	-
	120	23	84.4	10	120	116	5126	6030	1.07	NJ 213	HJ 213
	120	23	84.4	10	120	116	5126	6030	1.05	NU 213	HJ 213
	120	23	84.4	-	120	116	5126	6030	1.1	NUP 213	-
	120	31	84.4	10.5	167	176	5126	6030	1.45	NJ 2213	HJ 2213
	120	31	84.4	10.5	167	176	5126	6030	1.4	NU 2213	HJ 2213
	120	31	84.4	-	167	176	5126	6030	1.5	NUP 2213	-
	140	33	90.5	-	208	192	4590	5400	2.25	N 313	-
	140	33	90.5	15.5	208	192	4590	5400	2.3	NJ 313	HJ 313
	140	33	90.5	15.5	208	192	4590	5400	2.25	NU 313	HJ 313
	140	33	90.5	-	208	192	4590	5400	2.35	NUP 313	-
	140	48	90.5	18	279	284	4590	5400	3.35	NJ 2313	HJ 2313
	140	48	90.5	18	279	284	4590	5400	3.3	NU 2313	HJ 2313
	140	48	90.5	-	279	284	4590	5400	3.45	NUP 2313	-
	160	37	98.5	18	179	186	4284	5040	3.65	NJ 413	HJ 413
	160	37	98.5	18	179	186	4284	5040	3.6	NU 413	HJ 413
	70	110	20	84	10	75	91	5355	6300	0.62	NU 1014
125		24	89.4	-	134	134	4820	5670	1.15	N 214	-
125		24	89.4	11	134	134	4820	5670	1.15	NJ 214	HJ 214
125		24	89.4	11	134	134	4820	5670	1.15	NU 214	HJ 214
125		24	89.4	-	134	134	4820	5670	1.2	NUP 214	-
125		31	89.4	11.5	176	189	4820	5670	1.55	NJ 2214	HJ 2214
125		31	89.4	11.5	176	189	4820	5670	1.5	NU 2214	HJ 2214
125		31	89.4	-	176	189	4820	5670	1.55	NUP 2214	-
150		35	97.3	-	231	223	4284	5040	2.75	N 314	-

RODAMIENTOS DE UNA HILERA DE RODILLOS CILÍNDRICOS
CYLINDRICAL ROLLER BEARINGS, SINGLE ROW

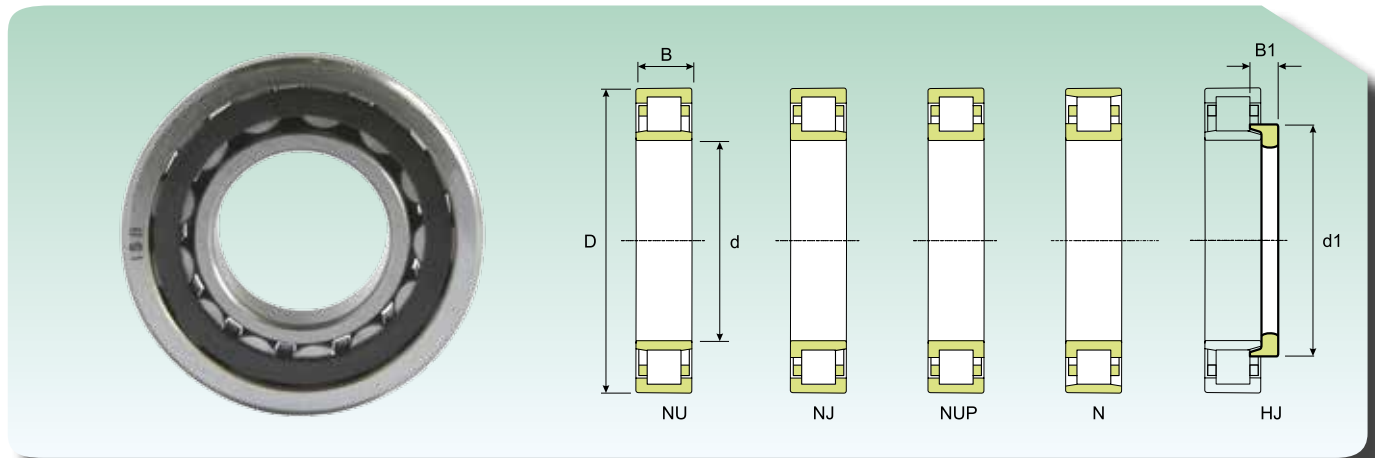

Dimensiones (mm) Dimension (mm)					Coeficiente de carga (kN) Load rating (kN)		Velocidad límite (rpm) Speed limit (Rpm)		Peso (Kg) Weight (Kg)	Sigla Designation	Aro angular Thrust collar	
d (mm)	D (mm)	B (mm)	d1 (mm)	B1 (mm)	Dinámico Dynamic C	Estático Static C ₀	Lubricación Lubrication					
							Grasa Grease	Aceite Oil				
70	150	35	97.3	15.5	231	223	4284	5040	2.8	NJ 314	HJ 314	
	150	35	97.3	15.5	231	223	4284	5040	2.75	NU 314	HJ 314	
	150	35	97.3	-	231	223	4284	5040	2.85	NUP 314	-	
	150	51	97.3	18.5	309	319	4284	5040	4.05	NJ 2314	HJ 2314	
	150	51	97.3	18.5	309	319	4284	5040	4	NU 2314	HJ 2314	
	150	51	97.3	-	309	319	4284	5040	4.15	NUP 2314	-	
	180	42	110	20	224	235	3825	4500	5.35	NJ 414	HJ 414	
	180	42	110	20	224	235	3825	4500	5.25	NU 414	HJ 414	
75	115	20	-	-	57	70	7650	9000	0.74	NU 1015	-	
	130	25	94.3	-	147	153	4590	5400	1.25	N 215	-	
	130	25	94.3	11	147	153	4590	5400	1.3	NJ 215	HJ 215	
	130	25	94.3	11	147	153	4590	5400	1.25	NU 215	HJ 215	
	130	25	94.3	-	147	153	4590	5400	1.3	NUP 215	-	
	130	31	94.3	-	182	204	4590	5400	1.6	NJ 2215	-	
	130	31	-	-	182	204	4590	5400	1.6	NU 2215	-	
	130	31	94.3	-	182	204	4590	5400	1.65	NUP 2215	-	
	160	37	104	-	274	260	4055	4770	3.3	N 315	-	
	160	37	104	16.5	274	260	4055	4770	3.35	NJ 315	HJ 315	
	160	37	104	16.5	274	260	4055	4770	3.3	NU 315	HJ 315	
	160	37	104	-	274	260	4055	4770	3.45	NUP 315	-	
	160	55	104	19.5	372	392	4055	4770	5	NJ 2315	HJ 2315	
	160	55	104	19.5	372	392	4055	4770	4.9	NU 2315	HJ 2315	
	160	55	104	-	372	392	4055	4770	5.1	NUP 2315	-	
	190	45	116	21.5	259	274	3672	4320	6.9	NJ 415	HJ 415	
190	45	116	21.5	259	274	3672	4320	6.25	NU 415	HJ 415		
80	125	22	-	-	65	80	4820	5670	1	NU 1016	-	
	125	22	96.2	-	97	124	7268	8550	1.1	NJ 1016	-	
	140	26	101	-	157	163	4284	5040	1.5	N 216	-	
	140	26	101	12.5	157	163	4284	5040	1.55	NJ 216	HJ 216	
	140	26	101	12.5	157	163	4284	5040	1.5	NU 216	HJ 216	
	140	26	101	12.5	157	163	4284	5040	1.6	NUP 216	-	
	140	33	101	12.5	208	240	4284	5040	2.05	NJ 2216	HJ2216	
	140	33	101	12.5	208	240	4284	5040	2	NU 2216	HJ 2216	
	140	33	101	-	208	240	4284	5040	2.1	NUP 2216	-	
	170	39	110	-	294	284	3825	4500	3.9	N 316	-	
	170	39	110	17	294	284	3825	4500	4	NJ 316	HJ 316	
	170	39	110	17	294	284	3825	4500	3.95	NU 316	HJ 316	
	170	39	110	-	294	284	3825	4500	4.1	NUP 316	-	
	170	58	110	20	407	431	3825	4500	6	NJ 2316	HJ2316	
	170	58	110	20	407	431	3825	4500	5.95	NU 2316	HJ 2316	
	170	58	110	-	407	431	3825	4500	6.6	NUP 2316	-	
	200	48	122	22	297	314	3443	4050	7.5	NJ 416	HJ 416	
	200	48	122	22	297	314	3443	4050	8.05	NU 416	HJ 416	
	85	130	22	-	-	67	85	6885	8100	1.05	NU 1017	-
		150	28	107	-	186	196	4055	4770	1.9	N 217	-
150		28	107	12.5	186	196	4055	4770	1.95	NJ 217	HJ 217	
150		28	107	12.5	186	196	4055	4770	1.9	NU 217	HJ 217	

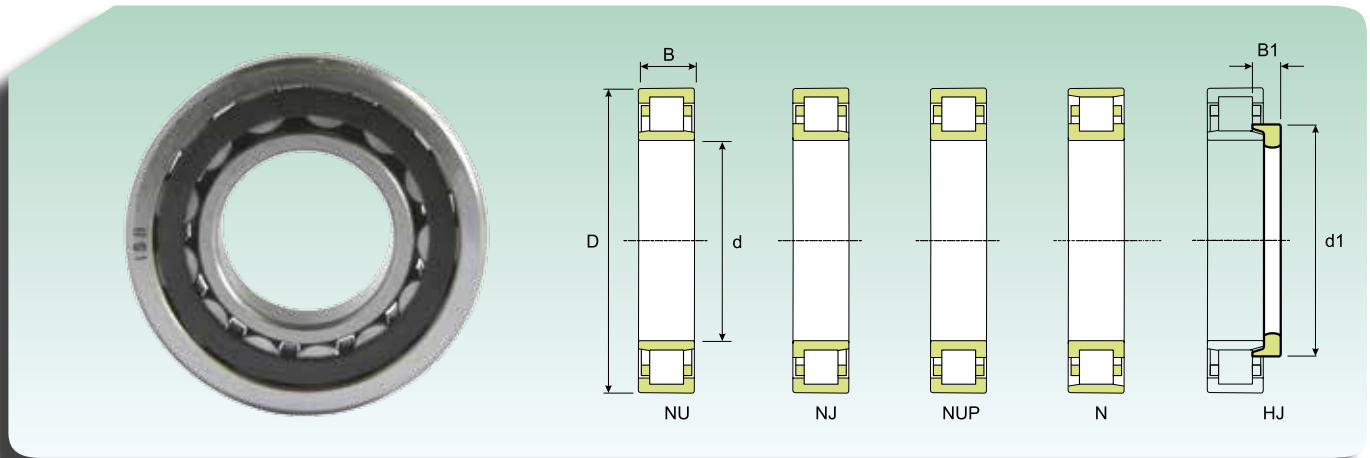
**RODAMIENTOS DE UNA HILERA DE RODILLOS CILÍNDRICOS
CYLINDRICAL ROLLER BEARINGS, SINGLE ROW**

Dimensiones (mm) Dimension (mm)					Coeficiente de carga (kN) Load rating (kN)		Velocidad límite (rpm) Speed limit (Rpm)		Peso (Kg) Weight (Kg)	Sigla Designation	Aro angular Thrust collar	
d (mm)	D (mm)	B (mm)	d1 (mm)	B1 (mm)	Dinámico Dynamic C	Estático Static C ₀	Lubricación Lubrication					
							Grasa Grease	Aceite Oil				
85	150	28	107	-	186	196	4055	4770	2	NUP 217	-	
	150	36	107	-	245	274	4055	4770	2.55	NJ 2217	-	
	150	36	-	-	245	274	4055	4770	2.45	NU 2217	-	
	150	36	107	-	245	274	4055	4770	2.65	NUP 2217	-	
	180	41	117	-	333	328	3672	4320	4.7	N 317	-	
	180	41	117	18.5	333	328	3672	4320	4.8	NJ 317	HJ 317	
	180	41	117	18.5	333	328	3672	4320	4.7	NU 317	HJ 317	
	180	41	117	-	333	328	3672	4320	4.9	NUP 317	-	
	180	60	117	22	446	480	3672	4320	7	NJ 2317	HJ 2317	
	180	60	117	22	446	480	3672	4320	6.85	NU 2317	HJ 2317	
	180	60	117	-	446	480	3672	4320	7	NUP 2317	-	
	210	52	126	24	313	328	3290	3870	8.9	NJ 417	HJ 417	
	210	52	126	24	313	328	3290	3870	9.7	NU 417	HJ 417	
	90	140	24	-	-	79	102	6503	7650	1.35	NU 1018	-
160		30	114	-	204	216	3825	4500	2.35	N 218	-	
160		30	114	14	204	216	3825	4500	2.4	NJ 218	HJ 218	
160		30	114	14	204	216	3825	4500	2.35	NU 218	HJ 218	
160		30	114	-	204	216	3825	4500	2.45	NUP 218	-	
160		40	114	15	274	309	3825	4500	3.2	NJ 2218	HJ 2218	
160		40	114	15	274	309	3825	4500	3.15	NU 2218	HJ 2218	
160		40	114	-	274	309	3825	4500	3.3	NUP 2218	-	
190		43	124	-	358	353	3443	4050	5.4	N 318	-	
190		43	124	18.5	358	353	3443	4050	5.55	NJ 318	HJ 318	
190		43	124	18.5	358	353	3443	4050	5.45	NU 318	HJ 318	
190		43	124	-	358	353	3443	4050	5.65	NUP 318	-	
190		64	124	22	490	529	3443	4050	8.15	NJ 2318	HJ 2318	
190		64	124	22	490	529	3443	4050	8	NU 2318	HJ 2318	
190		64	124	-	490	529	3443	4050	8.15	NUP 2318	-	
225		54	-	-	372	407	3060	3600	10.5	NU 418	-	
95		145	24	-	-	83	108	6120	7200	1.4	NU 1019	-
		170	32	120	-	250	260	3672	4320	2.85	N 219	-
	170	32	120	14	250	260	3672	4320	2.9	NJ 219	HJ 219	
	170	32	120	14	250	260	3672	4320	2.85	NU 219	HJ 219	
	170	32	120	-	250	260	3672	4320	3	NUP 219	-	
	170	43	120	-	319	368	3672	4320	3.95	NJ 2219	-	
	170	43	-	-	319	368	3672	4320	3.85	NU 2219	-	
	170	43	120	-	319	368	3672	4320	4	NUP 2219	-	
	200	45	132	-	382	382	3290	3870	6.25	N 319	-	
	200	45	132	20.5	382	382	3290	3870	6.45	NJ 319	HJ 319	
	200	45	132	20.5	382	382	3290	3870	6.25	NU 319	HJ 319	
	200	45	132	-	382	382	3290	3870	6.25	NUP 319	-	
	200	67	132	24.5	519	573	3290	3870	10.7	NJ 2319	HJ 2319	
	200	67	132	24.5	519	573	3290	3870	9.65	NU 2319	HJ 2319	
	200	67	132	-	519	573	3290	3870	9.75	NUP 2319	-	
	240	55	-	-	405	446	2754	3240	13.5	NU 419	-	

RODAMIENTOS DE UNA HILERA DE RODILLOS CILÍNDRICOS
CYLINDRICAL ROLLER BEARINGS, SINGLE ROW

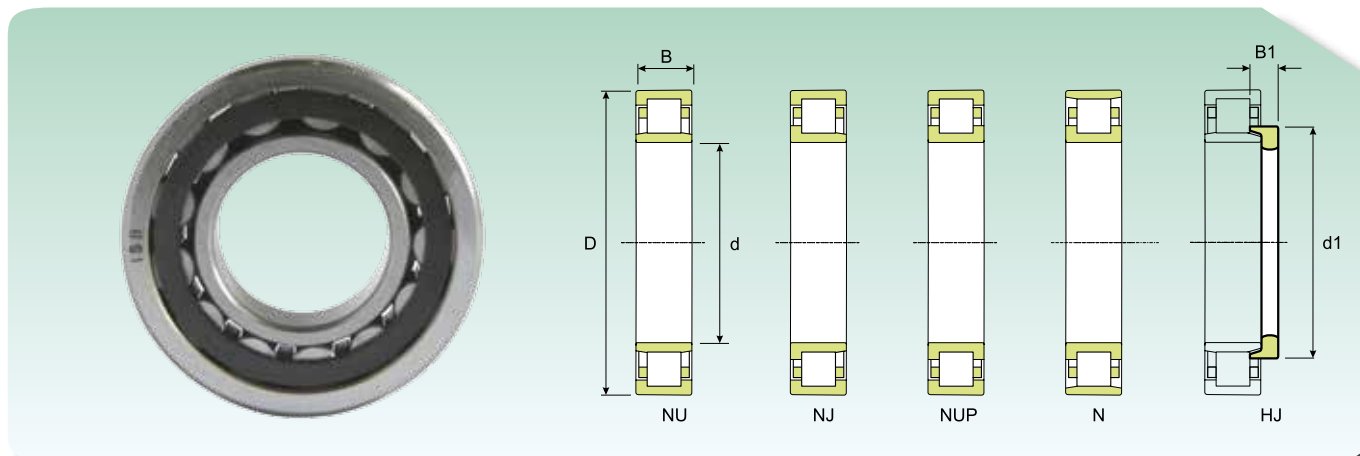

Dimensiones (mm) Dimension (mm)					Coeficiente de carga (kN) Load rating (kN)		Velocidad límite (rpm) Speed limit (Rpm)		Peso (Kg) Weight (Kg)	Sigla Designation	Aro angular Thrust collar
d (mm)	D (mm)	B (mm)	d1 (mm)	B1 (mm)	Dinámico Dynamic C	Estático Static C ₀	Lubrificación Lubrication				
							Grasa Grease	Aceite Oil			
100	150	24	-	-	84	112	5738	6750	1.45	NU 1020	-
	180	34	127	-	279	299	3443	4050	3.45	N 220	-
	180	34	127	15	279	299	3443	4050	3.5	NJ 220	HJ 220
	180	34	127	15	279	299	3443	4050	3.45	NU 220	HJ 220
	180	34	127	-	279	299	3443	4050	3.6	NUP 220	-
	180	46	127	16	372	441	3443	4050	4.8	NJ 2220	HJ 2220
	180	46	127	16	372	441	3443	4050	4.75	NU 2220	HJ 2220
	180	46	127	-	372	441	3443	4050	4.9	NUP 2220	-
	215	47	139	-	441	431	2907	3420	7.55	N 320	-
	215	47	139	20.5	441	431	2907	3420	7.65	NJ 320	HJ 320
	215	47	139	20.5	441	431	2907	3420	7.8	NU 320	HJ 320
	215	47	139	-	441	431	2907	3420	7.85	NUP 320	-
	215	73	139	23.5	657	720	2907	3420	12.2	NJ 2320	HJ 2320
	215	73	139	23.5	657	720	2907	3420	12	NU 2320	HJ 2320
215	73	139	-	657	720	2907	3420	12.5	NUP 2320	-	
250	58	153	27	420	466	2754	3240	14	NU 420	HJ 420	
105	160	26	-	-	99	134	5738	6750	1.85	NU 1021	-
	190	36	134	-	294	309	3290	3870	3.95	N 221	-
	190	36	134	17.5	294	309	3290	3870	4.1	NJ 221	HJ 221
	190	36	134	17.5	294	309	3290	3870	4	NU 221	HJ 221
	190	36	134	-	294	309	3290	3870	4	NUP 221	-
	225	49	145	-	490	490	2907	3420	9	NJ 321	-
	225	49	-	-	490	490	2907	3420	8.75	NU 321	-
	225	49	145	-	490	490	2907	3420	8.60	N 321	-
	260	60	-	-	491	559	2601	3060	19	NU 421	-
110	170	28	-	-	125	163	5355	6300	2.3	NU 1022	-
	200	38	141	-	328	358	3060	3600	4.8	N 222	-
	200	38	141	17	328	358	3060	3600	4.9	NJ 222	HJ 222
	200	38	141	17	328	358	3060	3600	4.8	NU 222	HJ 222
	200	38	141	-	328	358	3060	3600	5	NUP 222	-
	200	53	141	-	431	510	3060	3600	6.85	NJ 2222	-
	200	53	-	-	431	510	3060	3600	6.7	NU 2222	-
	200	53	141	-	431	510	3060	3600	7	NUP 2222	-
	240	50	155	-	519	529	2601	3060	10.5	N 322	-
	240	50	155	22	519	529	2601	3060	11.1	NJ 322	HJ 322
	240	50	155	22	519	529	2601	3060	10.8	NU 322	HJ 322
	240	50	155	-	519	529	2601	3060	11.2	NUP 322	-
	240	80	155	26.5	764	882	2601	3060	18.9	NJ 2322	HJ 2322
	240	80	155	26.5	764	882	2601	3060	17	NU 2322	HJ 2322
	240	80	155	-	764	882	2601	3060	17	NUP 2322	-
	280	65	171	29.5	521	573	2448	2880	20.3	NJ 422	HJ 422
	280	65	171	29.5	521	573	2448	2880	20	NU 422	HJ 422

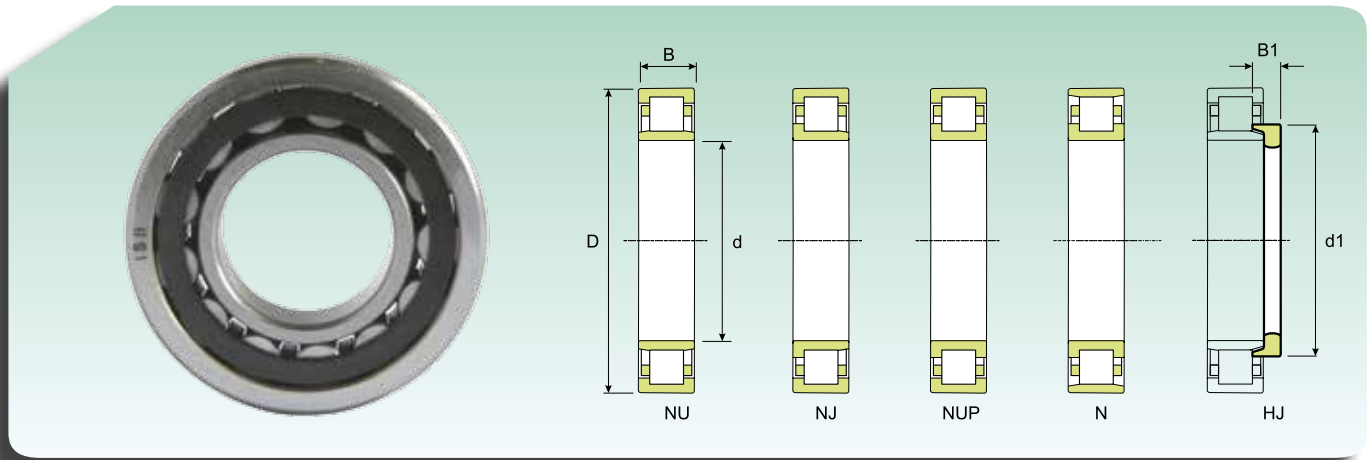
**RODAMIENTOS DE UNA HILERA DE RODILLOS CILÍNDRICOS
CYLINDRICAL ROLLER BEARINGS, SINGLE ROW**

Dimensiones (mm) Dimension (mm)					Coeficiente de carga (kN) Load rating (kN)		Velocidad límite (rpm) Speed limit (Rpm)		Peso (Kg) Weight (Kg)	Sigla Designation	Aro angular Thrust collar
d (mm)	D (mm)	B (mm)	d1 (mm)	B1 (mm)	Dinámico Dynamic C	Estático Static C ₀	Lubricación Lubrication				
							Grasa Grease	Aceite Oil			
120	180	28	-	-	131	179	4820	5670	2.45	NU 1024	-
	215	40	153	-	382	421	2754	3240	5.75	N 224	-
	215	40	153	17	382	421	2754	3240	5.85	NJ 224	HJ 224
	215	40	153	17	382	421	2754	3240	5.75	NU 224	HJ 224
	215	40	153	-	382	421	2754	3240	6	NUP 224	-
	215	58	153	20	510	617	2754	3240	8.5	NJ 2224	HJ 2224
	215	58	153	20	510	617	2754	3240	8.3	NU 2224	HJ 2224
	215	58	153	-	510	617	2754	3240	9	NUP 2224	-
	260	55	168	-	598	608	2448	2880	13.2	N 324	-
	260	55	168	22.5	598	608	2448	2880	13.5	NJ 324	HJ 324
	260	55	168	22.5	598	608	2448	2880	13.3	NU 324	HJ 324
	260	55	168	22.5	598	608	2448	2880	15	NUP 324	-
	260	86	168	26	897	1019	3290	3870	24.3	NJ 2324	HJ 2324
	260	86	168	26	897	1019	3290	3870	24	NU 2324	HJ 2324
260	86	168	-	897	1019	3290	3870	24.3	NUP 2324	-	
310	72	188	30.5	631	720	2142	2520	28	NU 424	HJ 424	
130	200	33	-	-	162	220	4284	5040	3.8	NU 1026	-
	230	40	164	-	407	446	2601	3060	6.3	N 226	-
	230	40	164	17	407	446	2601	3060	6.6	NJ 226	HJ 226
	230	40	164	17	407	446	2601	3060	6.45	NU 226	HJ 226
	230	40	164	-	407	446	2601	3060	6.75	NUP 226	-
	230	64	164	-	598	720	2601	3060	12.2	NJ 2226	-
	230	64	164	21	598	720	2601	3060	10.5	NU 2226	HJ 2226
	230	64	164	21	598	720	2601	3060	11	NUP 2226	-
	280	58	181	-	706	735	2295	2700	18.5	N 326	-
	280	58	181	23	706	735	2295	2700	18.4	NJ 326	HJ 326
	280	58	181	23	706	735	2295	2700	16.5	NU 326	HJ 326
	280	58	181	-	706	735	2295	2700	19.6	NUP 326	-
	280	93	181	28	1039	1225	2907	3420	30.5	NJ 2326	HJ 2326
	280	93	181	28	1039	1225	2907	3420	30	NU 2326	HJ 2326
	280	93	181	-	1039	1225	2907	3420	31	NUP 2326	-
	140	210	33	-	-	175	250	4055	4770	4.05	NU 1028
250		42	179	18	441	500	2448	2880	8.75	NJ 228	HJ 228
250		42	179	18	441	500	2448	2880	8.75	NU 228	HJ 228
250		42	179	-	441	500	2448	2880	8.9	NUP 228	-
250		68	179	23	655	810	3850	4300	15.0	NJ 2228	HJ 2228
250		68	179	23	655	810	3850	4300	15.3	NU 2228	HJ 2228
250		68	179	-	655	810	3850	4300	15.6	NUP 2228	-
300		62	195	25	764	813	3290	3870	23	NJ 328	HJ 328
300		62	195	25	764	813	3290	3870	22.7	NU 328	HJ 328
300		62	195	-	764	813	3290	3870	23.5	NUP 328	-
300		102	195	31	1176	1401	2754	3240	37.5	NJ 2328	HJ 2328
300		102	195	31	1176	1401	2754	3240	37	NU 2328	HJ 2328
300		102	195	-	1176	1401	2754	3240	37.5	NUP 2328	-

RODAMIENTOS DE UNA HILERA DE RODILLOS CILÍNDRICOS
CYLINDRICAL ROLLER BEARINGS, SINGLE ROW

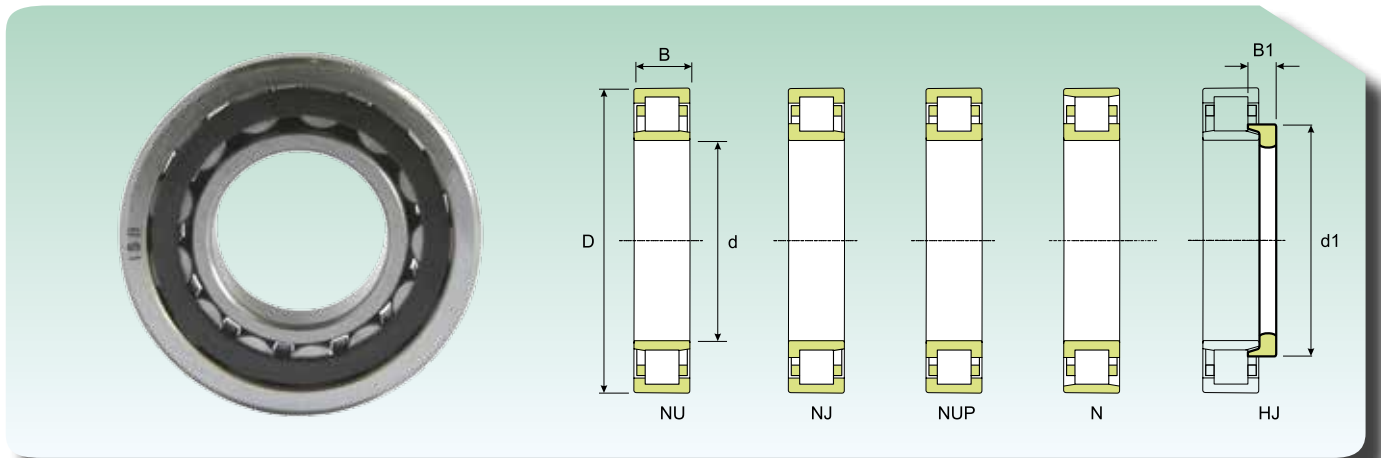

Dimensiones (mm) Dimension (mm)					Coeficiente de carga (kN) Load rating (kN)		Velocidad límite (rpm) Speed limit (Rpm)		Peso (Kg) Weight (Kg)	Sigla Designation	Aro angular Thrust collar	
d (mm)	D (mm)	B (mm)	d1 (mm)	B1 (mm)	Dinámico Dynamic C	Estático Static C ₀	Lubricación Lubrication					
							Grasa Grease	Aceite Oil				
150	225	35	-	-	194	284	3825	4500	4.85	NU 1030	-	
	270	45	193	19.5	500	588	2142	2520	10.8	NJ 230	HJ 230	
	270	45	193	19.5	500	588	2142	2520	10.6	NU 230	HJ 230	
	270	45	193	-	500	588	2142	2520	11	NUP 230	-	
	270	73	194	24.5	720	911	2142	2520	18.7	NJ 2230	HJ 2230	
	270	73	194	24.5	720	911	2142	2520	18.5	NU 2230	HJ 2230	
	320	65	209	25	882	946	2601	3060	27.7	NJ 330	HJ 330	
	320	65	209	25	882	946	1989	2340	27.5	NU 330	HJ 330	
	320	108	209	-	1343	1597	2601	3060	46	NJ 2330	-	
	320	108	209	-	1343	1597	2601	3060	45.5	NU 2330	-	
	320	108	209	-	1343	1597	2601	3060	46.5	NUP 2330	-	
	160	240	38	188	19	224	319	3672	4320	5.95	NU 1032	HJ 1032
290		48	206	-	573	666	1989	2340	14.3	N 232	-	
290		48	206	20	573	666	1989	2340	14.4	NJ 232	HJ 232	
290		48	206	20	573	666	1989	2340	14.2	NU 232	HJ 232	
290		48	206	-	573	666	1989	2340	14.5	NUP 232	-	
290		80	205	24.5	911	1176	2601	3060	24.7	NJ 2232	HJ 2232	
290		80	205	24.5	911	1176	2601	3060	24.2	NU 2232	HJ 2232	
340		68	221	25	980	1058	1836	2160	32.2	NJ 332	HJ 332	
340		68	221	25	980	1058	1836	2160	32	NU 332	HJ 332	
340		114	221	-	1225	1695	2448	2880	53.5	NJ 2332	-	
340		114	-	-	1225	1695	2448	2880	53	NU 2332	-	
170		260	42	201	21	270	392	3290	3870	8	NU 1034	HJ 1034
	310	52	220	20	681	799	1836	2160	18.7	NJ 234	HJ 234	
	310	52	220	20	681	799	1836	2160	18.2	NU 234	HJ 234	
	310	52	220	-	681	799	2448	2880	20	NUP 234	-	
	310	86	220	24	1039	1401	2448	2880	30	NU 2234	HJ 2234	
	360	72	236	-	933	1156	1683	1980	38.5	N 334	-	
	360	72	-	-	933	1156	1683	1980	37.5	NU 334	-	
	360	120	234	-	1421	1999	2295	2700	63	NJ 2334	-	
	360	120	-	-	1421	1999	2295	2700	63	NU 2334	-	
	180	280	46	215	22.5	329	466	3060	3600	10.5	NU 1036	HJ 1036
320		52	230	20	706	833	2448	2880	19.3	NJ 236	HJ 236	
320		52	230	20	706	833	2448	2880	19.1	NU 236	HJ 236	
320		52	230	-	706	833	2448	2880	21	NUP 236	-	
320		86	229	24	1078	1401	2448	2880	32	NJ 2236	HJ 2236	
320		86	229	24	1078	1401	2448	2880	31.5	NU 2236	HJ 2236	
380		75	-	-	1000	1264	1683	1980	45	NU 336	-	
380		126	-	-	1578	2195	2142	2520	71.5	NU 2336	-	
190		290	46	225	22.5	340	490	2907	3420	11	NU 1038	HJ 1038
		340	55	244	21.5	784	946	2295	2700	24.5	NJ 238	HJ 238
	340	55	244	21.5	784	946	2295	2700	24	NU 238	HJ 238	
	340	55	244	-	784	946	2295	2700	25	NUP 238	-	
	340	92	-	-	1196	1568	2295	2700	39	NU 238	-	
	400	78	264	29	1117	1470	153	180	50	NU 338	HJ 338	
	400	132	-	-	1793	2499	1989	2340	82.5	NU 2338	-	

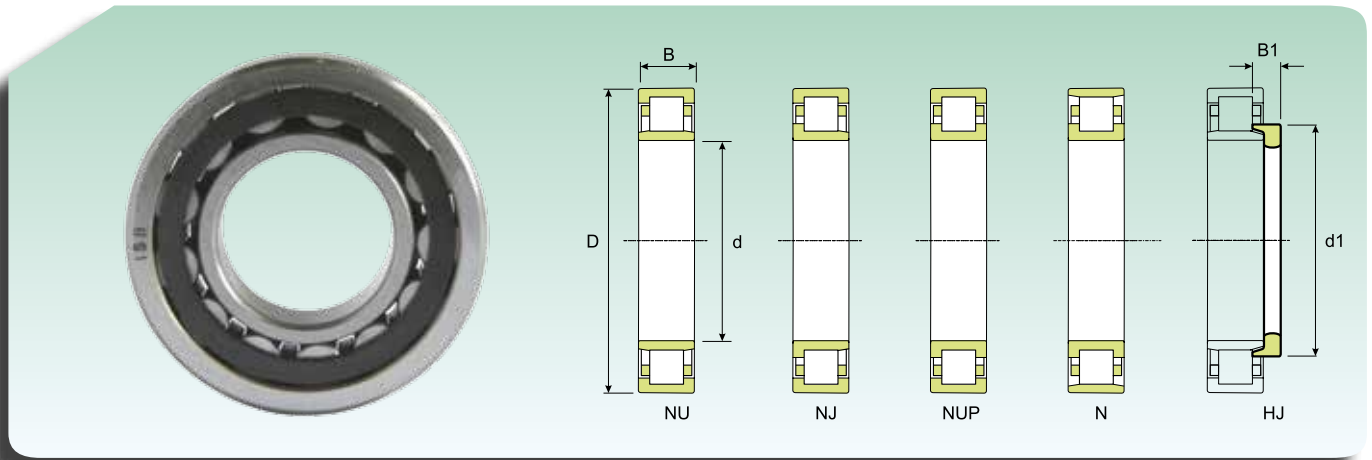
**RODAMIENTOS DE UNA HILERA DE RODILLOS CILÍNDRICOS
CYLINDRICAL ROLLER BEARINGS, SINGLE ROW**

Dimensiones (mm) Dimension (mm)					Coeficiente de carga (kN) Load rating (kN)		Velocidad límite (rpm) Speed limit (Rpm)		Peso (Kg) Weight (Kg)	Sigla Designation	Aro angular Thrust collar
d (mm)	D (mm)	B (mm)	d1 (mm)	B1 (mm)	Dinámico Dynamic C	Estático Static C ₀	Lubricación Lubrication				
							Grasa Grease	Aceite Oil			
200	310	51	239	25.5	372	559	2295	2700	14.5	NU 1040	HJ 1040
	360	58	258	23	833	1000	2142	2520	29	NJ 240	HJ 240
	360	58	258	23	833	1000	2142	2520	28.5	NU 240	HJ 240
	360	58	258	-	833	1000	2142	2520	29.5	NUP 240	-
	360	98	-	-	1343	1764	2142	2520	46	NU 2240	-
	420	80	-	-	1205	1597	1836	2160	57.5	NU 340	-
	420	138	278	-	1940	2744	1836	2160	97	NJ 2340	-
	420	138	-	-	1940	2744	1836	2160	96.5	NU 2340	-
220	340	56	262	27	485	720	2142	2520	18.5	NU 1044	HJ 1044
	400	65	284	25	1039	1264	1836	2160	38.2	NJ 244	HJ 244
	400	65	284	25	1039	1264	1836	2160	38	NU 244	HJ 244
	400	65	284	-	1039	1264	1836	2160	38.5	NUP 244	-
	400	108	-	-	1539	2234	1836	2160	62.5	NU 2244	-
	460	88	307	-	1186	1597	1301	1530	73.5	NJ 344	-
	460	88	-	-	1186	1597	1301	1530	72.5	NU 344	-
	460	145	-	-	2332	3381	1683	1980	120	NU 2344	-
240	360	56	282	27	515	784	2000	2300	20	NU 1048	HJ 1048
	440	72	-	-	933	1343	1683	1980	51.5	NU 248	-
	440	72	313	-	933	1343	1683	1980	51.5	NJ 248	-
	440	72	313	-	933	1343	1683	1980	53.5	NUP 248	-
	440	120	313	-	1421	2313	1683	1980	85	NJ 2248	-
	440	120	-	-	1421	2313	1683	1980	84	NU 2248	-
	500	95	335	39.5	1421	1960	1530	1800	98.5	NJ 348	HJ 348
	500	95	335	39.5	1421	1960	1224	1440	94.5	NU 348	HJ 348
	500	155	-	-	2548	3577	1530	1800	155	NU 2348	-
	260	400	65	309	31.5	614	946	1836	2160	29.5	NU 1052
480		80	340	33	1147	1666	1530	1800	70	NJ 252	HJ 252
480		80	340	33	1147	1666	1530	1800	68.5	NU 252	HJ 252
480		80	340	-	1147	1666	1530	1800	72	NUP 252	-
480		130	340	-	1754	2940	1530	1800	112	NJ 2252	-
480		130	-	-	1754	2940	1530	1800	110	NU 2252	-
540		102	-	-	1901	2646	1377	1620	125	NU 352	-
280		420	65	329	31.5	647	1039	1683	1980	31.5	NU 1056
	500	80	360	-	1117	1666	1454	1710	73	NJ 256	-
	500	80	-	-	1117	1666	1454	1710	71.5	NU 256	-
	500	130	350	38	2156	3185	1454	1710	115	NU 2256	HJ 2256
	580	175	-	-	2646	4214	1301	1530	230	NU 2356	-
300	460	74	356	36	841	1343	1530	1800	47	NJ 1060	HJ 1060
	460	74	356	36	841	1343	1530	1800	46.5	NU 1060	HJ 1060
	540	85	-	-	1392	2078	1377	1620	89.5	NU 260	-
	540	140	-	-	2048	3381	1377	1620	145	NU 2260	-
320	480	74	376	36	862	1401	1071	1260	49	NJ 1064	HJ 1064
	480	74	376	36	862	1401	1071	1260	48.5	NU 1064	HJ 1064
	580	92	-	-	1578	2401	1224	1440	115	NU 264	-
	580	150	-	-	3126	4900	1224	1440	190	NJ 2264	-

RODAMIENTOS DE UNA HILERA DE RODILLOS CILÍNDRICOS
CYLINDRICAL ROLLER BEARINGS, SINGLE ROW

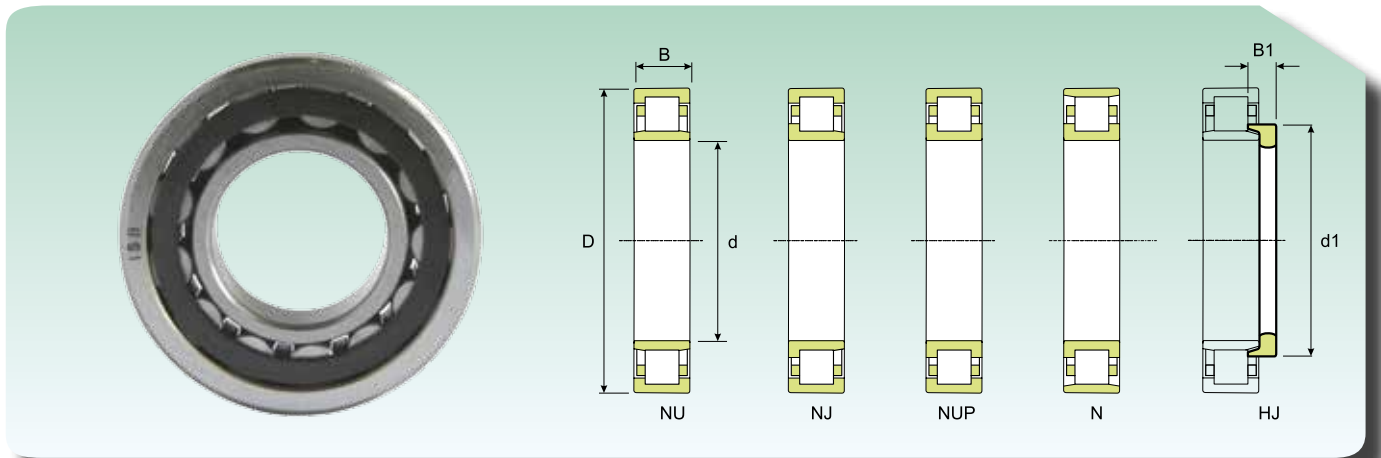

Dimensiones (mm) Dimension (mm)					Coeficiente de carga (kN) Load rating (kN)		Velocidad límite (rpm) Speed limit (Rpm)		Peso (Kg) Weight (Kg)	Sigla Designation	Aro angular Thrust collar
d (mm)	D (mm)	B (mm)	d1 (mm)	B1 (mm)	Dinámico Dynamic C	Estático Static C ₀	Lubricación Lubrication				
							Grasa Grease	Aceite Oil			
340	520	82	443	39.5	1058	1725	1301	1530	68	NJ 1068	HJ 1068
	520	82	443	39.5	1058	1725	1301	1530	65	NU 1068	HJ 1068
	620	165	-	-	2587	4410	1148	1350	220	NU 2268	-
360	540	82	423	39.5	1078	1793	1224	1440	67.5	NU 1072	HJ 1072
	650	170	-	-	2862	4802	1071	1260	250	NU 2272	-
380	560	82	443	39.5	1117	1891	1224	1440	73	NJ 1076	HJ 1076
	560	82	443	39.5	1117	1891	1224	1440	71	NU 1076	HJ 1076
	680	175	-	-	3881	6272	995	1170	275	NU 2276	-
400	600	90	400	43	1352	2274	1148	1350	92.5	NU 1080	HJ 1080
420	620	90	490	43	1392	2401	1071	1260	96	NU 1084	HJ 1084
440	650	94	512	45	1480	2597	995	1170	105	NU 1088	HJ 1088
460	680	100	537	48	1617	2793	918	1080	115	NU 1092	HJ 1092
	830	165	-	-	4096	6664	842	990	415	NU 1292	-
	830	212	-	-	5018	8477	842	990	530	NU 2292	-
480	700	100	557	48	1646	2940	918	1080	130	NU 1096	HJ 1096
500	720	100	577	48	1686	3038	842	990	135	NU 10/500	HJ 10/500
	920	185	-	-	5174	8330	727	855	585	NU 12/500	-
530	780	112	-	-	2244	3969	765	900	190	NU 10/530	-
	780	145	-	-	3665	7203	765	900	255	NU 20/530	-
560	680	56	-	-	781	1620	670	820	45.0	NJ 18/560	-
	820	115	648	53	2283	4165	765	900	210	NU 10/560	HJ 10/560
	820	150	-	-	3724	7497	765	900	290	NU 20/560	-
	1030	206	-	-	7066	10976	612	720	805	NU 12/560	-
600	800	90	-	-	1900	3680	500	650	130	NUP 19/600	-
	800	118	-	-	2920	6350	620	750	160	NU 29/600	-
	800	118	-	-	2920	6350	620	750	165	NUP 29/600	-
	870	118	695	55	2695	4998	689	810	245	NU 10/600	HJ 10/600
	870	200	-	-	5280	11200	500	600	410	N 30/600 K	-
	870	155	-	-	4096	7840	689	810	325	NU 20/600	-
	1090	155	-	-	5498	9604	650	765	710	NU 12/600	-
	630	780	88	-	-	1570	3610	630	750	90.0	NU 28/630
630	920	128	-	-	3342	6076	650	765	285	NU 10/630	-
	920	170	-	-	4635	9310	650	765	400	NU 20/630	-
	920	212	-	-	6440	14400	450	530	490	NU 30/630	-
	1150	230	-	-	8408	13426	536	630	1100	NU 12/630	-
670	820	69	-	-	1230	2690	550	650	84.0	NU 18/670	-
	900	103	-	-	2330	4600	530	650	195	NU 19/670	-
	980	136	-	-	3665	6664	430	500	350	NU 10/670	-
	980	180	-	-	5282	10780	430	500	480	NU 20/670	-
	980	230	-	-	6600	13800	430	500	615	NU 30/670	-
	980	230	-	-	6930	15000	430	500	605	N 30/670 K	-

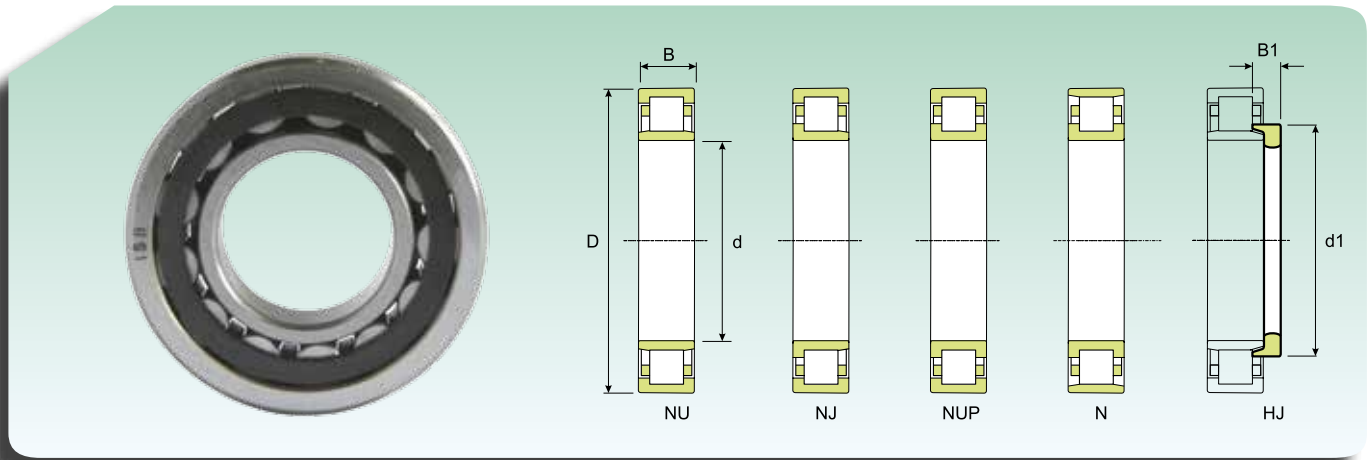
**RODAMIENTOS DE UNA HILERA DE RODILLOS CILÍNDRICOS
CYLINDRICAL ROLLER BEARINGS, SINGLE ROW**

Dimensiones (mm) Dimension (mm)					Coeficiente de carga (kN) Load rating (kN)		Velocidad límite (rpm) Speed limit (Rpm)		Peso (Kg) Weight (Kg)	Sigla Designation	Aro angular Thrust collar
d (mm)	D (mm)	B (mm)	d1 (mm)	B1 (mm)	Dinámico Dynamic C	Estático Static C ₀	Lubrificación Lubrication				
							Grasa Grease	Aceite Oil			
710	870	74	-	-	1450	3180	480	560	97.5	NU 18/710	-
	870	95	-	-	1940	4780	480	560	128	N 28/710	-
	1030	140	-	-	4586	8330	574	675	415	NU 10/710	-
	1030	185	-	-	5821	11760	536	630	540	NU 20/710	-
750	1090	150	-	-	4635	8624	513	603	490	NU 10/750	-
	1090	195	-	-	6899	14308	513	603	635	NU 20/750	-
800	1060	150	-	-	3690	8560	430	520	385	NU 29/800	-
	1150	200	-	-	6899	14308	482	567	715	NU 20/800	-
850	1030	106	-	-	2120	5610	420	480	190	NU 28/850	-
	1120	118	-	-	3050	6900	390	460	325	NU 19/850	-
	1120	118	-	-	2930	7000	390	460	326	NJ 19/850	-
	1120	155	-	-	4680	10800	350	460	435	NU 29/850	-
	1120	155	-	-	4680	10800	350	460	430	N 29/850	-
900	1090	85	-	-	1980	4600	370	440	170	NU 18/900	-
	1090	112	-	-	2700	6720	370	440	245	N 28/900	-
	1180	165	-	-	5120	11600	350	420	560	NU 29/900	-
	1180	122	-	-	4050	8700	350	420	378	NU 19/900M	-
950	1250	175	-	-	5280	12100	340	400	745	NU 29/950	-
1000	1220	100	-	-	2640	6160	310	380	265	NU 18/1000	-
	1320	185	-	-	6700	17000	290	350	705	NU 29/1000	-
1060	1280	128	-	-	3690	10100	350	420	360	N 28/1060	-
	1400	195	-	-	7200	17000	290	350	875	NU 29/1060M	-
	1400	250	-	-	9000	23500	250	310	1060	NU 39/1060M	-
1120	1360	140	-	-	3910	10500	270	380	465	N 28/1120	-
	1580	345	-	-	15700	39000	250	300	2150	NU 30/1120	-
1180	1420	106	-	-	3030	7360	170	210	350	NJ 18/1180	-
	1540	206	-	-	8970	21000	180	220	1010	NU 29/1180	-
	1540	272	-	-	11200	28200	190	250	1400	N 39/1180	-
1250	1750	290	-	-	13800	31300	165	190	2320	N 20/1250	-
1320	1600	122	-	-	3800	9380	190	250	530	NU 18/1320	-
	1720	230	-	-	11400	29400	180	230	1480	NU 29/1320	-
	1720	300	-	-	13200	33700	175	210	1950	N 39/1320	-
	1850	400	-	-	21200	53400	150	285	3550	N 30/1320	-
1500	1820	140	-	-	6220	17300	195	250	773	NU 18/1500	-
1700	2060	160	-	-	6950	18500	125	155	1156	NU 18/1700	-
1900	2300	175	-	-	8150	23700	90	115	1480	N 18/1900	-



Rodamientos de dos/cuatro hileras de rodillos cilíndricos

Cylindrical roller bearings, double/four row



RODAMIENTOS DE DOS HILERAS DE RODILLOS CILÍNDRICOS

Los rodamientos de dos hileras de rodillos cilíndricos son de dos tipos: NNU (**Fig. 1**) y NN (**Fig. 2**).

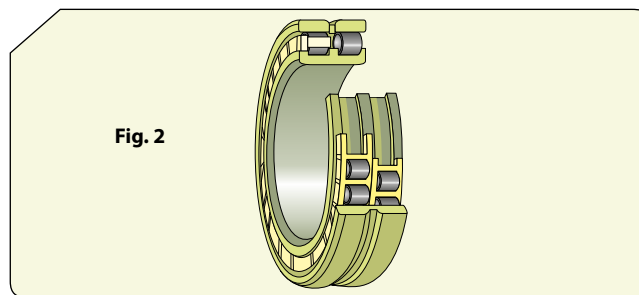
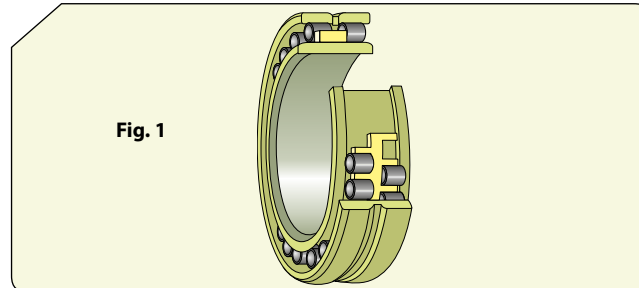

Los rodillos de los rodamientos de diseño NNU son guiados entre las pestañas del aro exterior mientras que aquellos de los rodamientos NN son guiados entre las pestañas del aro interior.

El otro aro no tiene pestañas. Estos rodamientos permiten por lo tanto, dentro de ciertos límites, desplazamientos axiales del eje respecto al alojamiento. Son desarmables, es decir que el aro con las pestañas, los rodillos y la jaula pueden quitarse del otro aro y montarse por separado. Su montaje resulta por lo tanto bastante simple.

Los rodamientos de dos hileras de rodillos cilíndricos generalmente tienen un pequeño espacio radial, una fuerte capacidad de carga y un reducido aflojamiento elástico. Las soluciones constructivas realizadas con estos rodamientos pueden soportar fuertes cargas y son muy rígidas. Estos rodamientos se emplean principalmente por lo tanto en las máquinas herramientas y en las máquinas de laminación, pero se montan también en grandes reductores industriales.

Los rodamientos de dos hileras de rodillos cilíndricos pueden suministrarse con agujero cilíndrico o cónico (conicidad 1:12). Para lograr más fácilmente una eficaz lubricación, prácticamente todos los rodamientos cuentan con ranura anular y tres o seis agujeros de lubricación en el aro exterior.

DOUBLE ROW CYLINDRICAL ROLLER BEARINGS

There are two types of double row cylindrical roller bearings: NNU (**Fig. 1**) and NN (**Fig. 2**).

The rollers of the NNU bearings are guided between the flanges of the outer ring while those of the NN bearings are guided between the flanges of the inner ring.

The other ring is flangeless. These bearings therefore enable, within certain limits, axial displacements of the shaft compared to the housing. They are separable, meaning that the flanged ring, the rollers and the cage can be taken out of the other ring and fitted separately. They are consequently relatively easy to assemble.

The double row cylindrical bearings generally have a small radial clearance, a strong load capacity and reduced elastic yielding. The manufacturing solutions fulfilled with these bearings are able to withstand strong loads and are remarkably rigid. These bearings are therefore used mainly in machine tools and roller presses but are also fitted on large industrial reduction units.

The double row cylindrical bearings can be supplied with cylindrical or tapered bore (taper 1:12). To facilitate efficient lubrication, basically all the bearings have an annular groove and three or six lubrication holes on the outer ring.

RODAMIENTOS DE CUATRO HILERAS DE RODILLOS CILÍNDRICOS

Los rodamientos de cuatro hileras de rodillos cilíndricos (**Fig. 3**) se montan casi exclusivamente en las máquinas de laminación. Los mismos presentan una fricción inferior a la de los otros rodamientos de rodillos y se pueden usar eficazmente cuando es necesario un funcionamiento a elevadas velocidades.

FOUR-ROW CYLINDRICAL ROLLER BEARINGS

The four-row cylindrical roller bearings (**Fig. 3**) are fitted almost exclusively in roller presses. Their friction is lower than that of other ball bearings and can be used successfully for high speed applications.

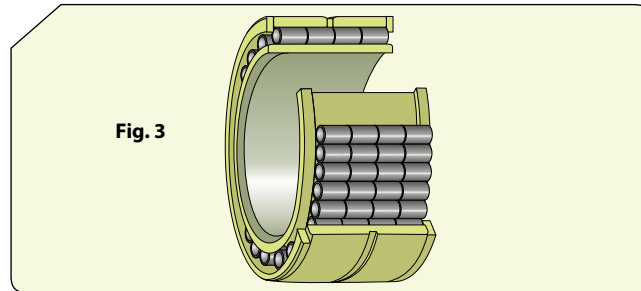

Se suministran en los diseños FC (**Fig. 4a**), FCP (**Fig. 4b**) y FCDP (**Fig. 4c**).

They are supplied in the following designs: FC (**Fig. 4a**), FCP (**Fig. 4b**) and FCDP (**Fig. 4c**).

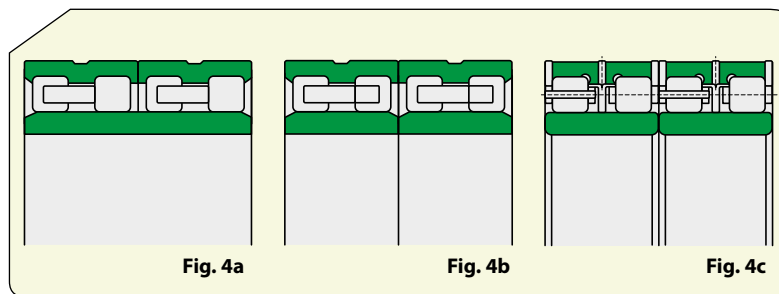

En los rodamientos de cuatro hileras de rodillos cilíndricos, los rodillos están guiados por el aro exterior entre pestañas integrales o no integrales. El aro interior no tiene pestañas; el rodamiento puede soportar por lo tanto, dentro de ciertos límites, desplazamientos axiales del eje respecto al alojamiento.

In the four-row cylindrical roller bearings, the rollers are guided on the outer ring between the integral flanges or non-integral flanges. The inner ring is flangeless; the bearing can therefore withstand, within certain limits, axial displacements of the shaft compared to the housing.

Según la aplicación, los rodamientos de cuatro hileras de rodillos cilíndricos pueden suministrarse con agujero cilíndrico o cónico. Los aros interiores y exteriores pueden constituir una sola pieza o varias.

Based on the application involved, the four-row cylindrical roller bearings can be supplied with cylindrical or tapered bore. The inner and outer rings may be in just one piece or in a number of pieces.

Los rodamientos pueden soportar por lo tanto un cierto desplazamiento axial del eje respecto al alojamiento.

The bearings are therefore able to withstand a certain axial displacement of the shaft compared to the housing.

DIMENSIONES

Las dimensiones de los rodamientos **ISB**[®] de una hilera de rodillos cilíndricos respetan la norma ISO 15:1998.

DIMENSIONS

The dimensions of **ISB**[®] single row cylindrical roller bearings comply with standard ISO 15:1998.

Los diámetros exterior e interior de muchos de los rodamientos de cuatro hileras de rodillos cilíndricos corresponden a los valores estandarizados para las Series 9 o 0.

The outside and inside diameters of many of the four-row cylindrical roller bearings match the standard values of the 9 or 0 diameter series.

TOLERANCIAS

Todos los rodamientos con número de dibujo del diseño NN están fabricados según las clases de precisión normal; aquellos de diseño NNU tienen una precisión dimensional conforme con la clase P6 y una precisión de marcha correspondiente a la clase P5.

Los rodamientos de cuatro hileras de rodillos cilíndricos con agujero cilíndrico o cónico tienen una precisión dimensional correspondiente a la clase P6 y una precisión de marcha conforme con la clase P5.

JUEGO

Los rodamientos de dos hileras de rodillos cilíndricos se suministran generalmente con juego radial C1 (como requerido para aplicaciones en máquinas herramientas); esto no está indicado en la designación. Los aros de estos rodamientos no deben ser intercambiados entre sí, de lo contrario el juego puede resultar demasiado grande o demasiado pequeño.

Los rodamientos de la clase de precisión SP, especialmente aquellos de la serie NNU 49, pueden suministrarse también con juego radial sobredimensionado, generalmente C3, necesario para las aplicaciones en las máquinas de laminado.

Los rodamientos de cuatro hileras de rodillos cilíndricos con agujero cilíndrico y agujero cónico se suministran con juego radial C3 o C4, según la aplicación.

DESALINEACIÓN

Los rodamientos de dos y cuatro hileras de rodillos cilíndricos están diseñados para poder afrontar cierta desalineación.

TEMPERATURA DE FUNCIONAMIENTO

Sometiéndolos a especiales tratamientos térmicos, equipados con jaula de acero o de latón, pueden ser empleados a temperaturas de hasta + 150°C. Si está prevista una jaula de poliamida 6.6 la temperatura máxima de servicio podrá alcanzar los + 120°C.

JAULAS

Los rodamientos de dos hileras de rodillos cilíndricos cuentan generalmente con una jaula monobloque, mecanizada, de latón, con espigas dobles o con dos jaulas separadas, con espiga, en poliamida 6,6 reforzada con fibras de vidrio (sufijo TN9). Algunos rodamientos tienen sus jaulas de acero del tipo de pernos.

Los rodamientos de cuatro hileras de rodillos cilíndricos montan dos jaulas mecanizadas de latón o de acero de espiga doble o cuatro jaulas de acero del tipo de pernos.

TOLERANCES

All the bearings with NN design number are manufactured according to the normal precision class; the dimensional precision of those with NNU design number complies with class P6 and a running precision compliant with class P5.

The dimensional precision of the four-row cylindrical roller bearings with cylindrical or tapered bore complies with class P6 and they have a running precision compliant with class P5.

CLEARANCE

The double row cylindrical roller bearings are normally supplied with radial clearance C1 (as requested for applications on machine tools); this is not indicated in the product name. The rings of these bearings must not be swapped, otherwise the clearance becomes too large or too small.

The bearings with precision class SP, especially those of the NNU 49 series, can also be supplied with uprated radial clearance, generally C3, required for applications in roller presses.

The four-row cylindrical roller bearings with cylindrical bore and tapered bore are supplied with radial clearance C3 or C4, based on the application.

MISALIGNMENT

The double and four-row cylindrical roller bearings are not designed to withstand any misalignment.

OPERATING TEMPERATURE

They are put through special heat treatments. When equipped with steel or brass cage, they can be used at temperatures up to + 150°C. When equipped with cage made of polyamide 6.6, the maximum operating temperature is + 120°C.

CAGES

The double row cylindrical ball bearings are generally equipped either with a double pronged solid brass cage or two separate pronged polyamide 6.6 cages reinforced with fibreglass (suffix TN9). Some bearings have two pin-type steel cages.

The four-row cylindrical roller bearings fit either two double pronged solid brass or steel cages or four pin-type steel cages.

DESIGNACIONES SUPLEMENTARIAS

C2	Juego interno radial inferior al Normal
C3	Juego interno radial mayor que el Normal
C4	Juego interno radial mayor que C3
J	Jaula moldeada de chapa de acero
K	Agujero conico, conicidad 1:12
M	Jaula mecanizada de latón, en dos partes, centrada en los rodillos
MA	Jaula mecanizada de latón en dos partes, centrada en el aro exterior
MB	Jaula mecanizada de latón en dos partes centrada en el aro interior
N	Ranurado para aro de fijación en el diámetro exterior del aro exterior
NR	Ranurado e idóneo aro de fijación en el aro externo
P	Jaula moldeada por inyección, en poliamida 6.6. reforzada con fibra de vidrio
W33	Ranura anular y tres agujeros de lubricación en el aro exterior
K30	Agujero conico, conicidad 1:30
TN9	Jaula moldeada por inyección, de montaje a presión, en poliamida 6.6 reforzada con fibras de vidrio centrada en las bolas

SUPPLEMENTARY DESIGNATIONS

C2	<i>Internal radial clearance smaller than Normal</i>
C3	<i>Internal radial clearance greater than Normal</i>
C4	<i>Internal radial clearance greater than C3</i>
J	<i>Pressed steel cage</i>
K	<i>Tapered bore, taper 1:12</i>
M	<i>Solid two-piece machined brass cage, centred on the rollers</i>
MA	<i>Solid two-piece machined brass cage centered on the outer ring</i>
MB	<i>Solid two-piece machined brass cage centered on the inner ring</i>
N	<i>Groove for snap ring in outside diameter of outer ring</i>
NR	<i>Groove and snap ring on outer ring</i>
P	<i>Injection moulded cage made of polyamide 6.6 with fibreglass reinforcement</i>
W33	<i>Circumferential groove and three lubrication holes in outer ring</i>
K30	<i>Tapered bore, taper 1:30</i>
TN9	<i>Shield made of pressed sheet steel on both sides of the bearing</i>

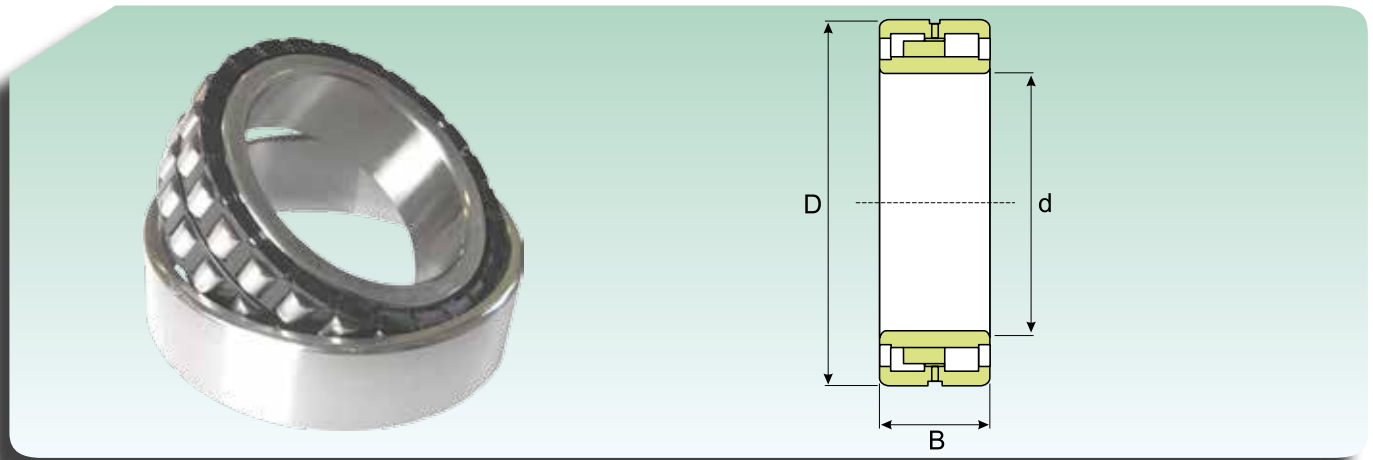
**RODAMIENTOS DE DOS HILERAS DE RODILLOS CILÍNDRICOS
CYLINDRICAL ROLLER BEARINGS, DOUBLE ROW**

Dimensiones (mm) Dimension (mm)			Coeficiente de carga (KN) Load rating (KN)		Velocidad límite (rpm) Speed limit (Rpm)		Peso (Kg) Weight (Kg)	Sigla Designation
d (mm)	D (mm)	B (mm)	Dinámico Dynamic C	Estático Static C ₀	Lubrificación Lubrication			
					Grasa Grease	Aceite Oil		
105	175	69	404.74	656.6	3870	4085	6,7	NUU 4121 K30M/W33
	175	69	404.74	656.6	3870	4085	6,7	NUU 4121 M/W33
110	180	69	409.64	695.8	3870	4085	6,95	NUU 4122 K30M/W33
	180	69	409.64	695.8	3870	4085	6,95	NUU 4122 M/W33
120	200	80	512.54	847.7	3420	3610	11	NUU 4124 K30M/W33
	200	80	512.54	847.7	3420	3610	11	NUU 4124 M/W33
130	210	80	549.78	945.7	3240	3420	10,7	NUU 4126 K30M/W33
	210	80	549.78	945.7	3240	3420	10,7	NUU 4126 M/W33
140	225	85	614.46	1019.2	3060	3230	13	NUU 4128 K30M/W33
	225	85	614.46	1019.2	3060	3230	13	NUU 4128 M/W33
150	250	100	733.04	1264.2	2700	2850	18	NUU 4130 K30M/W33
	250	100	733.04	1264.2	2700	2850	18	NUU 4130 M/W33
160	270	109	916.3	1499.4	2520	2660	25	NUU 4132 K30M/W33
	270	109	916.3	1499.4	2520	2660	25	NUU 4132 M/W33
170	280	109	948.64	1597.4	2340	2470	26	NUU 4134 K30M/W33
	280	109	948.64	1597.4	2340	2470	26	NUU 4134 M/W33
180	300	118	1058.4	1793.4	2160	2280	32,5	NUU 4136 K30M/W33
	300	118	1058.4	1793.4	2160	2280	32,5	NUU 4136 M/W33
190	320	128	1293.6	2156	2160	2280	41	NUU 4138 K30M/W33
	320	128	1293.6	2156	2160	2280	41	NUU 4138 M/W33
200	250	50	237.16	588	2340	2470	5,75	NUU 4840 K/W33
	250	50	237.16	588	2340	2470	5,75	NUU 4840/W33
	340	140	1440.6	2499	1980	2090	51	NUU 4140 K30M/W33
	340	140	1440.6	2499	1980	2090	51	NUU 4140 M/W33
220	370	150	1617	2842	1800	1900	65	NUU 4144 K30M/W33
	370	150	1617	2842	1800	1900	65	NUU 4144 M/W33
240	300	60	350.84	911.4	2160	2280	9,9	NUU 4848 K/W33
	300	60	350.84	911.4	2160	2280	9,9	NUU 4848/W33
	400	160	1940.4	3577	1620	1710	85	NUU 4148 K30M/W33
	400	160	1940.4	3577	1620	1710	85	NUU 4148 M/W33
260	400	140	1617	3087	1620	1710	63,5	NUU 4052 KM/W33
	400	140	1617	3087	1620	1710	63,5	NUU 4052 M/W33
	440	180	2156	3822	1440	1520	110	NUU 4152 K30M/W33
	440	180	2156	3822	1440	1520	110	NUU 4152 M/W33
280	350	69	447.86	1176	1710	1805	15,5	NUU 4856 K/W33
	350	69	447.86	1176	1710	1805	15,5	NUU 4856/W33
	420	140	1617	3087	1530	1615	66,5	NUU 4056 KM/W33
	420	140	1617	3087	1530	1615	66,5	NUU 4056 M/W33
	460	180	2499	4655	1350	1425	120	NUU 4156 K30M/W33
	460	180	2499	4655	1350	1425	120	NUU 4156 M/W33

RODAMIENTOS DE DOS HILERAS DE RODILLOS CILÍNDRICOS
CYLINDRICAL ROLLER BEARINGS, DOUBLE ROW

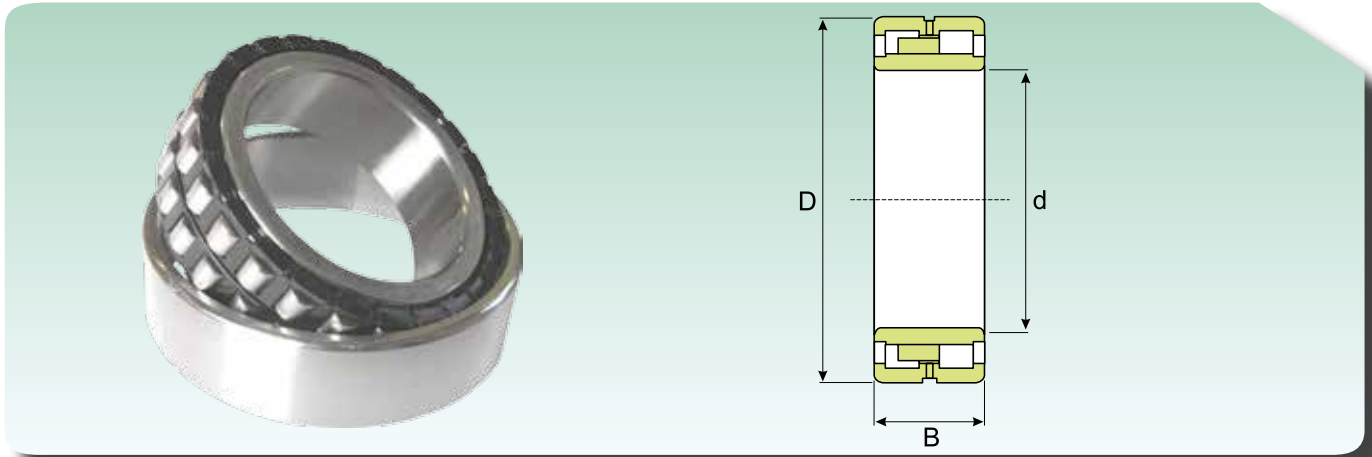

Dimensiones (mm) Dimension (mm)			Coeficiente de carga (kN) Load rating (kN)		Velocidad límite (rpm) Speed limit (Rpm)		Peso (Kg) Weight (Kg)	Sigla Designation
d (mm)	D (mm)	B (mm)	Dinámico Dynamic C	Estático Static C ₀	Lubricación Lubrication			
					Grasa Grease	Aceite Oil		
300	380	80	776.16	2077.6	1530	1615	22	NNU 4860 K/W33
	380	80	776.16	2077.6	1530	1615	22	NNU 4860/W33
	460	160	1969.8	3920	1350	1425	96	NNU 4060 KM/W33
	460	160	1969.8	3920	1350	1425	96	NNU 4060 M/W33
	500	200	2802.8	5194	1260	1330	155	NNU 4160 K30M/W33
	500	200	2802.8	5194	1260	1330	155	NNU 4160 M/W33
320	400	80	749.7	2038.4	1440	1520	23,5	NNU 4864 K/W33
	400	80	749.7	2038.4	1440	1520	23,5	NNU 4864/W33
	480	160	2077.6	4214	1260	1330	100	NNU 4064 KM/W33
	480	160	2077.6	4214	1260	1330	100	NNU 4064 M/W33
	540	218	3341.8	6076	1170	1235	200	NNU 4164
	540	218	3341.8	6076	1170	1235	200	NNU 4164 K30
340	420	80	631.12	1793.4	1350	1425	25	NNU 4868 K/W33
	420	80	631.12	1793.4	1350	1425	25	NNU 4868/W33
	520	180	2499	4998	1170	1235	140	NNU 4068 KM/W33
	520	180	2499	4998	1170	1235	140	NNU 4068 M/W33
	580	243	3939.6	7350	1080	1140	260	NNU 4168 K30M/W33
	580	243	3939.6	7350	1080	1140	260	NNU 4168 M/W33
360	540	180	2753.8	5586	1080	1140	142	NNU 4072 KM/W33
	540	180	2753.8	5586	1080	1140	142	NNU 4072 M/W33
	600	243	4204.2	8330	990	1045	275	NNU 4172 K30M
	600	243	4204.2	8330	990	1045	275	NNU 4172 M
380	480	100	932.96	2499	1170	1235	44	NNU 4876 K/W33
	480	100	932.96	2499	1170	1235	44	NNU 4876/W33
	560	180	2802.8	5880	1080	1140	150	NNU 4076 KM/W33
	560	180	2802.8	5880	1080	1140	150	NNU 4076 M/W33
	620	243	4204.2	8330	990	1045	285	NNU 4176 K30M
	620	243	4204.2	8330	990	1045	285	NNU 4176 M
400	500	100	948.64	2695	1080	1140	46	NNU 4880 K/W33
	500	100	948.64	2695	1080	1140	46	NNU 4880/W33
	600	200	3400.6	7056	990	1045	205	NNU 4080 W33
	600	200	3400.6	7056	990	1045	205	NNU 4080 K/W33
	650	250	4635.4	9310	900	950	325	NNU 4180 K30M/W33
	650	250	4635.4	9310	900	950	325	NNU 4180 M/W33
420	520	100	970.2	2793	1080	1140	48	NNU 4884 K/W33
	520	100	970.2	2793	1080	1140	48	NNU 4884/W33
	620	200	3449.6	7350	855	902,5	183	NNU 4084 KM/W33
	620	200	3449.6	7350	855	902,5	183	NNU 4084 M/W33
	700	280	5390	11172	855	902,5	440	NNU 4184/316275
440	540	100	989.8	2842	990	1045	50	NNU 4888 K/W33
	540	100	989.8	2842	990	1045	50	NNU 4888/W33
	650	212	3831.8	8134	855	902,5	215	NNU 4088 KM/W33
	650	212	3831.8	8134	855	902,5	215	NNU 4088 M/W33
	720	280	5605.6	11564	810	855	450	NNU 4188 K30M/W33
	720	280	5605.6	11564	810	855	450	NNU 4188 M/W33

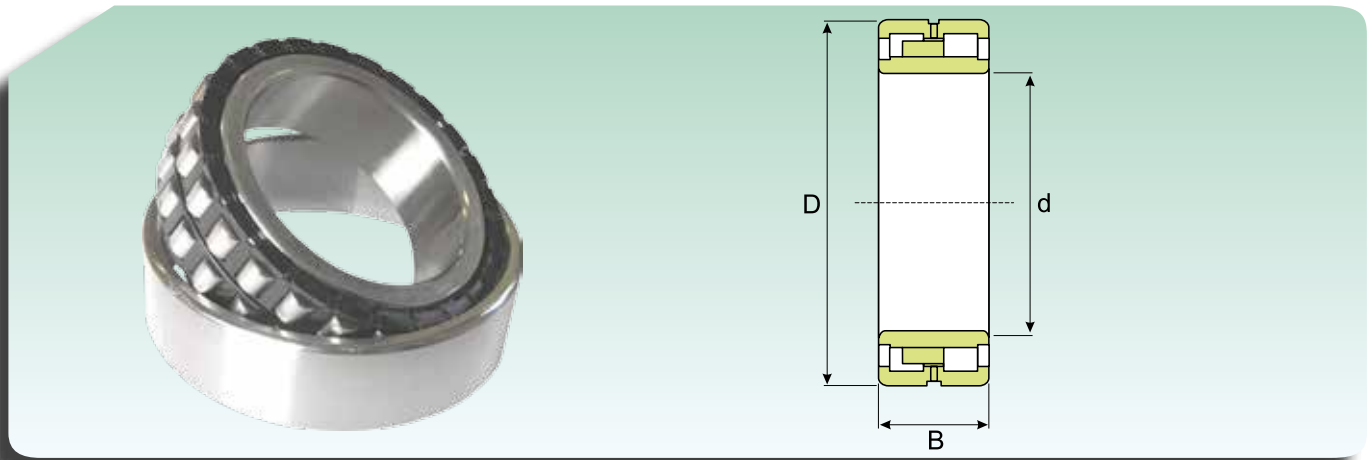
**RODAMIENTOS DE DOS HILERAS DE RODILLOS CILÍNDRICOS
CYLINDRICAL ROLLER BEARINGS, DOUBLE ROW**

Dimensiones (mm) Dimension (mm)			Coeficiente de carga (kN) Load rating (kN)		Velocidad límite (rpm) Speed limit (Rpm)		Peso (Kg) Weight (Kg)	Sigla Designation
d (mm)	D (mm)	B (mm)	Dinámico Dynamic C	Estático Static C ₀	Lubricación Lubrication			
					Grasa Grease	Aceite Oil		
460	580	118	1166.2	3185	990	1045	75	NUU 4892 K/W33
	580	118	1166.2	3185	990	1045	75	NUU 4892/W33
	680	218	4204.2	9114	855	902,5	240	NUU 4092 KM/W33
	680	218	4204.2	9114	855	902,5	240	NUU 4092 M/W33
	760	300	6311.2	12642	765	807,5	535	NUU 4192 K30M
	760	300	6311.2	12642	765	807,5	535	NUU 4192 M
480	700	218	4312	9457	810	855	275	NUU 4096 KM/W33
	700	218	4312	9457	810	855	275	NUU 4096 M/W33
	790	308	6899.2	14014	720	760	590	NUU 4196 K30M/W33
	790	308	6899.2	14014	720	760	590	NUU 4196 M/W33
500	720	218	4370.8	9800	765	807,5	287	NUU 40/500 KM/W33
	720	218	4370.8	9800	765	807,5	287	NUU 40/500 M/W33
	830	325	7330.4	14700	720	760	710	NUU 41/500 K30M/W33
	830	325	7330.4	14700	720	760	710	NUU 41/500 M/W33
530	780	250	5390	11956	720	760	420	NUU 40/530 KM/W33
	780	250	5390	11956	720	760	420	NUU 40/530 M/W33
	870	335	7653.8	15680	675	712,5	790	NUU 41/530 K30M/W33
	870	335	7653.8	15680	675	712,5	790	NUU 41/530 M/W33
560	820	258	5605.6	12642	675	712,5	475	NUU 40/560 KM/W33
	820	258	5605.6	12642	675	712,5	475	NUU 40/560 M/W33
	920	355	8624	17934	603	636,5	930	NUU 41/560 K30M/W33X
	920	355	8624	17934	603	636,5	930	NUU 41/560 M/W33
600	870	272	6683.6	15288	630	665	530	NUU 40/600 KM/W33
	870	272	6683.6	15288	630	665	530	NUU 40/600 M/W33
	980	375	9702	20776	567	598,5	1100	NUU 41/600 K30M/W33
	980	375	9702	20776	567	598,5	1100	NUU 41/600 M/W33
630	920	290	7497	17248	567	598,5	635	NUU 40/630 KM/W33
	920	290	7497	17248	567	598,5	635	NUU 40/630 M/W33
	1030	400	10780	23520	540	570	1330	NUU 41/630 K30M/W33
	1030	400	10780	23520	540	570	1330	NUU 41/630 M/W33
670	980	308	8251.6	19208	540	570	765	NUU 40/670 KM/W33
	980	308	8251.6	19208	540	570	765	NUU 40/670 M/W33
	1090	412	11858	24990	477	503,5	1500	NUU 41/670 K30M/W33
	1090	412	11858	24990	477	503,5	1500	NUU 41/670 M/W33
710	1030	315	9163	21168	504	532	850	NUU 40/710 KM/W33
	1030	315	9163	21168	504	532	850	NUU 40/710 M/W33
	1150	438	13132	27930	450	475	1790	NUU 41/710 K30M/W33
	1150	438	13132	27930	450	475	1790	NUU 41/710 M/W33
750	920	170	3616.2	9996	540	570	240	NU 48/750 K30/H1W33
	920	170	3616.2	9996	540	570	240	NU 48/750/H1W33
	1090	335	9996	23520	450	475	925	NUU 40/750 KM/W33
	1090	335	9996	23520	450	475	925	NUU 40/750 M/W33
	1220	475	15778	34790	405	427,5	2230	NUU 41/750 K30M/W33
	1220	475	15778	34790	405	427,5	2230	NUU 41/750 M/W33

RODAMIENTOS DE DOS HILERAS DE RODILLOS CILÍNDRICOS
CYLINDRICAL ROLLER BEARINGS, DOUBLE ROW

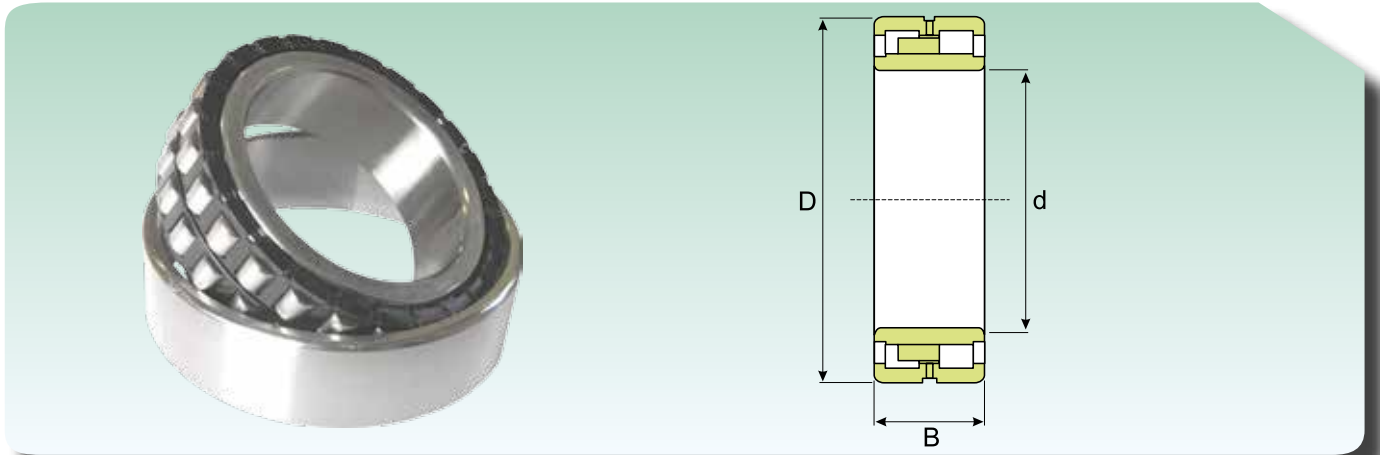

Dimensiones (mm) Dimension (mm)			Coeficiente de carga (KN) Load rating (KN)		Velocidad límite (rpm) Speed limit (Rpm)		Peso (Kg) Weight (Kg)	Sigla Designation
d (mm)	D (mm)	B (mm)	Dinámico Dynamic C	Estático Static C ₀	Lubricación Lubrication			
					Grasa Grease	Aceite Oil		
800	1150	345	10584	25480	432	456	1140	NUU 40/800 KM/W33
	1150	345	10584	25480	432	456	1140	NUU 40/800 M/W33
	1280	475	16170	35770	387	408,5	2390	NUU 41/800 K30M/W33
	1280	475	16170	35770	387	408,5	2390	NUU 41/800 M/W33
850	1220	365	11466	27930	387	408,5	1340	NUU 40/850 KM/W33
	1220	365	11466	27930	387	408,5	1340	NUU 40/850 M/W33
	1360	500	19404	44100	360	380	2900	NUU 41/850 K30M/W33
	1360	500	19404	44100	360	380	2900	NUU 41/850 M/W33
900	1280	375	12544	30870	360	380	1500	NUU 40/900 KM/W33
	1280	375	12544	30870	360	380	1500	NUU 40/900 M/W33
	1420	515	21560	46550	324	342	3180	NUU 41/900 K30M/W33
	1420	515	21560	46550	324	342	3180	NUU 41/900 M/W33
950	1360	412	13916	34790	342	361	1900	NUU 40/950 KM/W33
	1360	412	13916	34790	342	361	1900	NUU 40/950 M/W33
	1500	545	24990	55860	306	323	3830	NUU 41/950 K30M/W33
	1500	545	24990	55860	306	323	3830	NUU 41/950 M/W33
1000	1320	315	8408.4	25480	360	380	1200	NN 49/1000 K/W33X
	1320	315	8408.4	25480	360	380	1200	NN 49/1000 W33X
	1420	412	15092	37240	306	323	2000	NUU 40/1000 KM/W33
	1420	412	15092	37240	306	323	2000	NUU 40/1000 M/W33
	1580	580	26950	60760	270	285	4270	NUU 41/1000 K30M/W33
	1580	580	26950	60760	270	285	4270	NUU 41/1000 M/W33
1060	1660	600	29694	68110	252	266	5070	NUU 41/1060 K30M/W33
	1660	600	29694	68110	252	266	5070	NUU 41/1060 M/W33
1120	1750	630	32928	74970	252	266	5600	NUU 41/1120 K30M/W33
	1750	630	32928	74970	252	266	5600	NUU 41/1120 M/W33
1180	1850	670	36162	83300	216	228	7200	NUU 41/1180 K30M/W33
	1850	670	36162	83300	216	228	7200	NUU 41/1180 M/W33
1250	1950	710	40964	96040	198	209	8000	NUU 41/1250 K30M/W33
	1950	710	40964	96040	198	209	8000	NUU 41/1250 M/W33
1320	1720	400	13524	41650	252	266	3060	NN 49/1320 W33
	1720	400	13524	41650	252	266	3060	NN 49/1320 K/W33
	2060	750	44786	103880	171	180,5	9400	NUU 41/1320 K30M/W33
	2060	750	44786	103880	171	180,5	9400	NUU 41/1320 M/W33
1400	2180	775	48510	113680	153	161,5	10700	NUU 41/1400 K30M/W33
	2180	775	48510	113680	153	161,5	10700	NUU 41/1400 M/W33
1500	2300	800	51744	129360	135	142,5	12300	NUU 41/1500 K30M/W33
	2300	800	51744	129360	135	142,5	12300	NUU 41/1500 M/W33

RODAMIENTOS DE DOS HILERAS DE RODILLOS CILÍNDRICOS , DE ALTA PRECISIÓN CYLINDRICAL ROLLER BEARINGS, DOUBLE ROW, HIGH-PRECISION

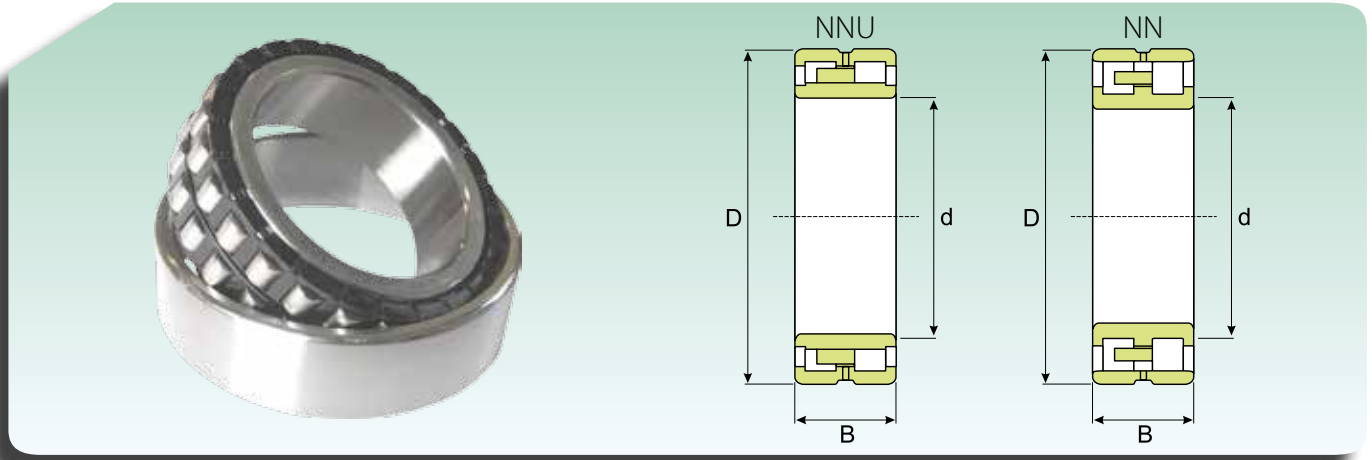

Dimensiones (mm) Dimension (mm)			Coeficiente de carga (kN) Load rating (kN)		Velocidad límite (rpm) Speed limit (Rpm)		Peso (Kg) Weight (Kg)	Sigla Designation
d (mm)	D (mm)	B (mm)	Dinámico Dynamic C	Estático Static C ₀	Lubrificación Lubrication			
					Grasa Grease	Aceite Oil		
25	47	16	25,48	29,4	18430	21340	0,12	NN 3005 K/SP
	47	16	25,48	29,4	18430	21340	0,12	NN 3005/SP
30	55	19	30,184	36,75	15520	17460	0,19	NN 3006 KTN/SP
	55	19	30,184	36,75	15520	17460	0,19	NN 3006 TN/SP
35	62	20	38,318	49	13580	15520	0,25	NN 3007 K/SP
	62	20	38,318	49	13580	15520	0,25	NN 3007/SP
40	68	21	42,042	54,88	11640	13580	0,30	NN 3008 KTN/SP
	68	21	42,042	54,88	11640	13580	0,30	NN 3008 TN/SP
45	75	23	49,098	64,19	10670	12610	0,38	NN 3009 KTN/SP
	75	23	49,098	64,19	10670	12610	0,38	NN 3009 TN/SP
50	80	23	51,744	72,03	9700	11640	0,42	NN 3010 KTN/SP
	80	23	51,744	72,03	9700	11640	0,42	NN 3010 TN/SP
55	90	26	67,914	94,57	9215	10670	0,62	NN 3011 KTN/SP
	90	26	67,914	94,57	9215	10670	0,62	NN 3011 TN/SP
60	95	26	72,226	103,88	8730	9700	0,66	NN 3012 KTN/SP
	95	26	72,226	103,88	8730	9700	0,66	NN 3012 TN/SP
65	100	26	74,97	113,68	8245	9215	0,71	NN 3013 KTN/SP
	100	26	74,97	113,68	8245	9215	0,71	NN 3013 TN/SP
70	110	30	94,864	147	7275	8245	1,00	NN 3014 KTN/SP
	110	30	94,864	147	7275	8245	1,00	NN 3014 TN/SP
75	115	30	94,864	147	6790	7760	1,10	NN 3015 KTN/SP
	115	30	94,864	147	6790	7760	1,10	NN 3015 TN/SP
80	125	34	116,62	182,28	6499	7275	1,45	NN 3016 KTN/SP
	125	34	116,62	182,28	6499	7275	1,45	NN 3016 TN/SP
85	130	34	122,5	199,92	6111	6790	1,60	NN 3017 KTN9/SP
	130	34	122,5	199,92	6111	6790	1,60	NN 3017 TN9/SP
90	140	37	135,24	211,68	5820	6499	2,00	NN 3018 KTN9/SP
	140	37	135,24	211,68	5820	6499	2,00	NN 3018 TN9/SP
95	145	37	139,16	227,36	5432	6111	2,10	NN 3019 KTN9/SP
	145	37	139,16	227,36	5432	6111	2,10	NN 3019 TN9/SP
100	140	40	125,44	249,9	5432	6111	1,90	NNU 4920 SPW33
	140	40	125,44	249,9	5432	6111	1,90	NNU 4920 K/SPW33
	150	37	147,98	245	5141	5820	2,20	NN 3020 KTN9/SP
	150	37	147,98	245	5141	5820	2,20	NN 3020 TN9/SP
105	145	40	127,4	254,8	5141	5820	2,00	NNU 4921 SPW33
	145	40	127,4	254,8	5141	5820	2,00	NNU 4921 K/SPW33
	160	41	186,2	298,9	4850	5432	2,70	NN 3021 KTN9/SP
	160	41	186,2	298,9	4850	5432	2,70	NN 3021 TN9/SP

RODAMIENTOS DE DOS HILERAS DE RODILLOS CILÍNDRICOS , DE ALTA PRECISIÓN CYLINDRICAL ROLLER BEARINGS, DOUBLE ROW, HIGH-PRECISION

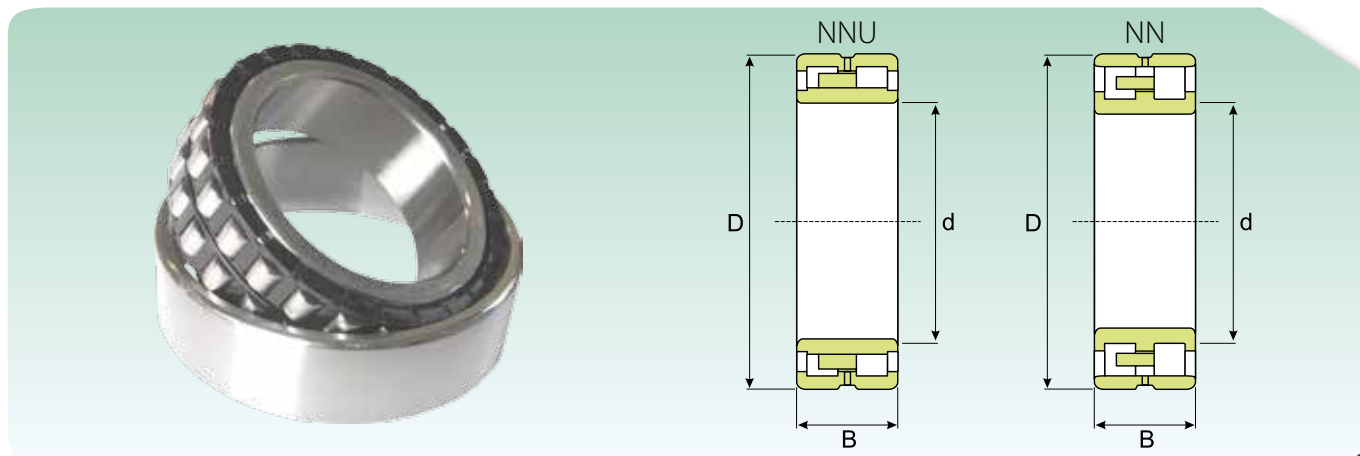

Dimensiones (mm) Dimension (mm)			Coeficiente de carga (kN) Load rating (kN)		Velocidad límite (rpm) Speed limit (Rpm)		Peso (Kg) Weight (Kg)	Sigla Designation
d (mm)	D (mm)	B (mm)	Dinámico Dynamic C	Estático Static C ₀	Lubrificación Lubrication			
					Grasa Grease	Aceite Oil		
110	150	40	129,36	264,6	5141	5820	2,05	NNU 4922 SPW33
	150	40	129,36	264,6	5141	5820	2,05	NNU 4922 K/SPW33
	170	45	215,6	352,8	4656	5141	3,40	NN 3022 KTN9/SP
	170	45	215,6	352,8	4656	5141	3,40	NN 3022 TN9/SP
120	165	45	172,48	333,2	4656	5141	2,80	NNU 4924 SPW33
	165	45	172,48	333,2	4656	5141	2,80	NNU 4924 K/SPW33
	180	46	224,42	382,2	4365	4850	3,70	NN 3024 KTN9/SP
	180	46	224,42	382,2	4365	4850	3,70	NN 3024 TN9/SP
130	180	50	183,26	382,2	4171	4656	3,85	NNU 4926 SPW33
	180	50	183,26	382,2	4171	4656	3,85	NNU 4926 K/SPW33
	200	52	280,28	470,4	3880	4365	5,55	NN 3026 KTN9/SP
	200	52	280,28	470,4	3880	4365	5,55	NN 3026 TN9/SP
140	190	50	186,2	392	3880	4365	4,10	NNU 4928 SPW33
	190	50	186,2	392	3880	4365	4,10	NNU 4928 K/SPW33
	210	53	291,06	509,6	3686	4171	6,00	NN 3028 K/SPW33
	210	53	291,06	509,6	3686	4171	6,00	NN 3028/SPW33
150	210	60	323,4	641,9	3686	4171	6,25	NNU 4930 SPW33
	210	60	323,4	641,9	3686	4171	6,25	NNU 4930 K/SPW33
	225	56	323,4	558,6	3492	3880	7,30	NN 3030 K/SPW33
	225	56	323,4	558,6	3492	3880	7,30	NN 3030/SPW33
160	220	60	323,4	666,4	3492	3880	6,60	NNU 4932 SPW33
	220	60	323,4	666,4	3492	3880	6,60	NNU 4932 K/SPW33
	240	60	361,62	641,9	3298	3686	8,80	NN 3032 K/SPW33
	240	60	361,62	641,9	3298	3686	8,80	NN 3032/SPW33
170	230	60	329,28	681,1	3298	3686	6,95	NNU 4934 SPW33
	230	60	329,28	681,1	3298	3686	6,95	NNU 4934 K/SPW33
	260	67	447,86	784	3104	3492	12,0	NN 3034 K/SPW33
	260	67	447,86	784	3104	3492	12,0	NN 3034/SPW33
180	250	69	393,96	833	2910	3298	10,5	NNU 4936 SPW33
	250	69	393,96	833	2910	3298	10,5	NNU 4936 K/SPW33
	280	74	549,78	980	2716	3104	16,0	NN 3036 K/SPW33
	280	74	549,78	980	2716	3104	16,0	NN 3036/SPW33
190	260	69	393,96	862,4	2716	3104	11,0	NNU 4938 SPW33
	260	69	393,96	862,4	2716	3104	11,0	NNU 4938 K/SPW33
	290	75	582,12	1058,4	2522	2910	17,0	NN 3038 K/SPW33
	290	75	582,12	1058,4	2522	2910	17,0	NN 3038/SPW33
200	280	80	474,32	1019,2	2522	2910	15,0	NNU 4940 SPW33
	280	80	474,32	1019,2	2522	2910	15,0	NNU 4940 K/SPW33
	310	82	631,12	1117,2	2328	2716	21,0	NN 3040 K/SPW33
	310	82	631,12	1117,2	2328	2716	21,0	NN 3040/SPW33
220	300	80	501,76	1117,2	2328	2716	16,5	NNU 4944 SPW33
	300	80	501,76	1117,2	2328	2716	16,5	NNU 4944 K/SPW33
	340	90	792,82	1430,8	2134	2522	27,5	NN 3044 K/SPW33
	340	90	792,82	1430,8	2134	2522	27,5	NN 3044/SPW33

RODAMIENTOS DE DOS HILERAS DE RODILLOS CILÍNDRICOS , DE ALTA PRECISIÓN CYLINDRICAL ROLLER BEARINGS, DOUBLE ROW, HIGH-PRECISION

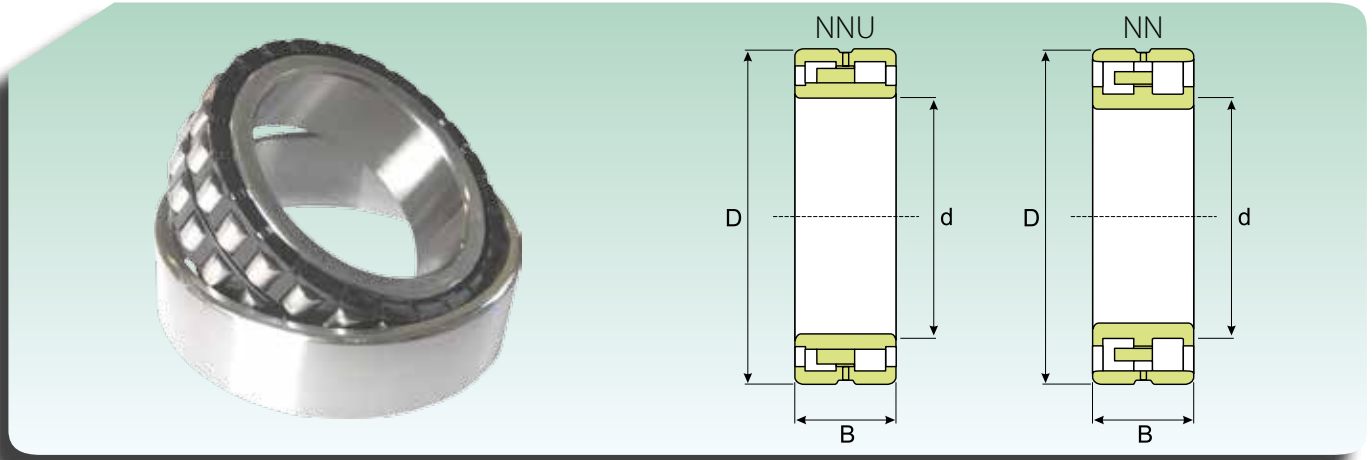

Dimensiones (mm) Dimension (mm)			Coeficiente de carga (kN) Load rating (kN)		Velocidad límite (rpm) Speed limit (Rpm)		Peso (Kg) Weight (Kg)	Sigla Designation
d (mm)	D (mm)	B (mm)	Dinámico Dynamic C	Estático Static C ₀	Lubrificación Lubrication			
					Grasa Grease	Aceite Oil		
240	320	80	517,44	1195,6	2134	2522	17,5	NNU 4948 SPW33
	320	80	517,44	1195,6	2134	2522	17,5	NNU 4948 K/SPW33
	360	92	825,16	1528,8	1940	2328	30,5	NN 3048 K/SPW33
	360	92	825,16	1528,8	1940	2328	30,5	NN 3048/SPW33
260	360	100	733,04	1666	1940	2328	30,5	NNU 4952 SPW33
	360	100	733,04	1666	1940	2328	30,5	NNU 4952 K/SPW33
	400	104	999,6	1891,4	1843	2134	44,0	NN 3052 K/SPW33
	400	104	999,6	1891,4	1843	2134	44,0	NN 3052/SPW33
280	380	100	749,7	1764	1843	2134	32,5	NNU 4956 SPW33
	380	100	749,7	1764	1843	2134	32,5	NNU 4956 K/SPW33
	420	106	1058,4	2038,4	1746	1940	47,5	NN 3056 K/SPW33
	420	106	1058,4	2038,4	1746	1940	47,5	NN 3056/SPW33
300	420	118	999,6	2312,8	1746	1940	48,0	NNU 4960 SPW33
	420	118	999,6	2312,8	1746	1940	48,0	NNU 4960 K/SPW33
	460	118	1225	2352	1649	1843	66,5	NN 3060 K/SPW33
	460	118	1225	2352	1649	1843	66,5	NN 3060/SPW33
320	440	118	1038,8	2450	1649	1843	50,0	NNU 4964 SPW33
	440	118	1038,8	2450	1649	1843	50,0	NNU 4964 K/SPW33
	480	121	1293,6	2548	1552	1746	71,0	NN 3064 K/SPW33
340	460	118	1078	2597	1455	1649	53,0	NNU 4968 SPW33
	460	118	1078	2597	1455	1649	53,0	NNU 4968 K/SPW33
	520	133	1617	3185	1358	1552	94,5	NN 3068 K/SPW33
360	480	118	1097,6	2744	1455	1649	55,0	NNU 4972 SPW33
	480	118	1097,6	2744	1455	1649	55,0	NNU 4972 K/SPW33
	540	134	1685,6	3381	1261	1455	102	NN 3072 K/SPW33
380	520	140	1421	3528	1261	1455	83,5	NNU 4976 SPW33
	520	140	1421	3528	1261	1455	83,5	NNU 4976 K/SPW33
	560	135	1646,4	3381	1261	1455	105	NN 3076 K/SPW33
400	540	140	1440,6	3724	1261	1455	87,5	NNU 4980 SPW33
	540	140	1440,6	3724	1261	1455	87,5	NNU 4980 K/SPW33
	600	148	2116,8	4410	1164	1358	135	NN 3080 K/SPW33
420	560	140	1479,8	3920	1164	1358	91,0	NNU 4984 SPW33
	560	140	1479,8	3920	1164	1358	91,0	NNU 4984 K/SPW33
	620	150	2077,6	4410	1067	1261	140	NN 3084 K/SPW33
460	620	160	2048,2	5390	970	1164	130	NNU 4992 SPW33
	620	160	2048,2	5390	970	1164	130	NNU 4992 K/SPW33
	680	163	2548	5390	970	1164	190	NN 3092 K/SPW33
500	670	170	2283,4	5978	921,5	1067	165	NNU 49/500 SPW33X
	670	170	2283,4	5978	921,5	1067	165	NNU 49/500 K/SPW33X
600	800	200	3508,4	9996	776	873	280	NNU 49/600 SPW33X
	800	200	3508,4	9996	776	873	280	NNU 49/600 K/SPW33X
670	900	230	4851	13426	679	776	410	NNU 49/670 SPW33X
	900	230	4851	13426	679	776	410	NNU 49/670 K/SPW33X

RODAMIENTOS DE CUATRO HILERAS DE RODILLOS CILÍNDRICOS
CYLINDRICAL ROLLER BEARINGS, FOUR-ROW

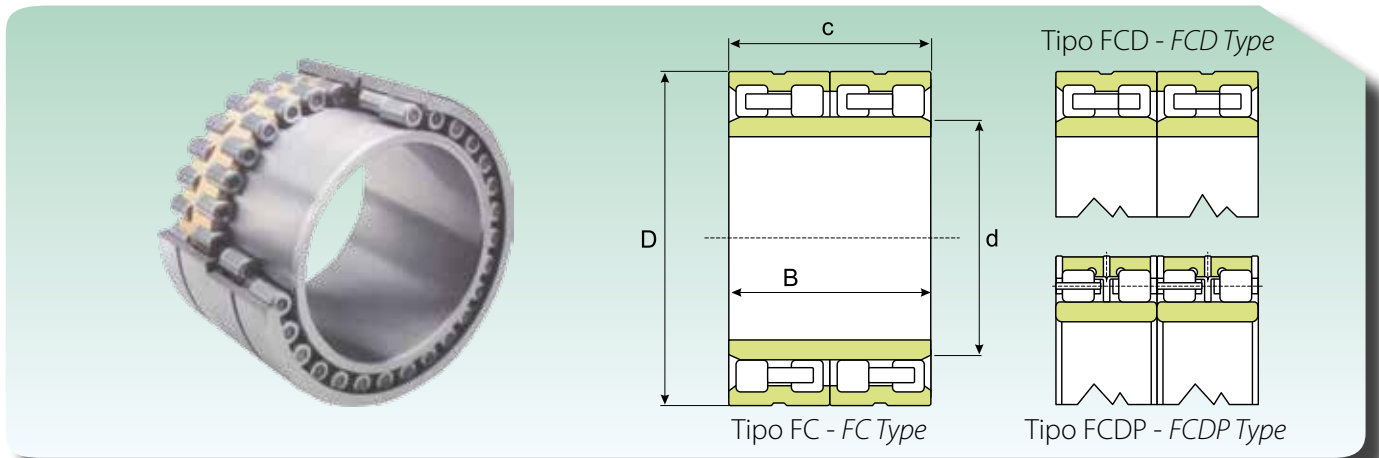

Dimensiones (mm) Dimension (mm)				Coeficiente de carga (KN) Load rating (KN)		Peso (Kg) Weight (Kg)	Sigla Designation
d (mm)	D (mm)	B (mm)	c (mm)	Dinámico Dynamic C	Estático Static C ₀		
90	140	70	70	253	425	3.78	FC 182870
100	140	70	70	209	435	3.10	FC 202870
	140	104	104	330	775	4.99	FC 2028104
	150	106	106	425	890	6.67	FC 2030106
110	170	120	120	534	1110	10.1	FC 2234120
120	180	105	105	413	770	9.13	FC 2436105
130	200	125	125	583	1200	14.6	FC 2640125
140	210	125	125	594	1160	14.7	FC 2842125
145	210	155	155	751	1610	18.3	FC 2942155
150	225	120	120	710	1450	16.7	FC 3045120
	225	120	120	710	1450	16.6	FCD 3045120
	230	156	156	852	1790	23.6	FC 3046156
160	230	130	130	742	1705	16.9	FC 3246130
	240	124	124	810	1530	20.3	FC 3248124
	240	168	168	1060	2350	26.4	FC 3248168
170	230	160	160	1210	2360	20.0	FCD 3446160
	250	170	170	1280	2500	28.5	FC 3450170
	260	120	120	867	1790	24.6	FC 3452120
	260	150	150	1000	2240	29.7	FC 3452150
180	260	124	124	809	1730	21.7	FC 3652124
	260	168	168	1180	2790	30.2	FC 3652168
	260	180	180	1250	3000	31.1	FC 3652180
190	270	168	168	1420	2430	30.2	FC 3854168
	270	170	170	1430	2430	30.2	FC 3854170
	270	200	200	1520	3180	35.0	FC 3854200
200	270	170	170	1120	2270	28.7	FC 4054170
	280	188	188	1430	2580	35.7	FC 4056188
	290	192	192	1460	3250	40.9	FC 4058192
210	300	170	170	1320	3150	39.1	FC 4260170
	300	210	210	1560	3950	48.3	FC 4260210
220	310	192	192	1600	1910	45.8	FC 4462192
	310	225	225	1850	4050	53.9	FC 4462225
	320	210	210	1900	4000	57.1	FCD 4464210
230	330	206	206	1880	4350	57.8	FC 4666206
	340	260	260	2120	5350	82.1	FC 4668260
240	330	220	220	1780	4850	56.7	FC 4866220
	360	200	200	1870	4410	78.0	FC 4872220
250	350	220	220	1740	4980	65.5	FC 5070220

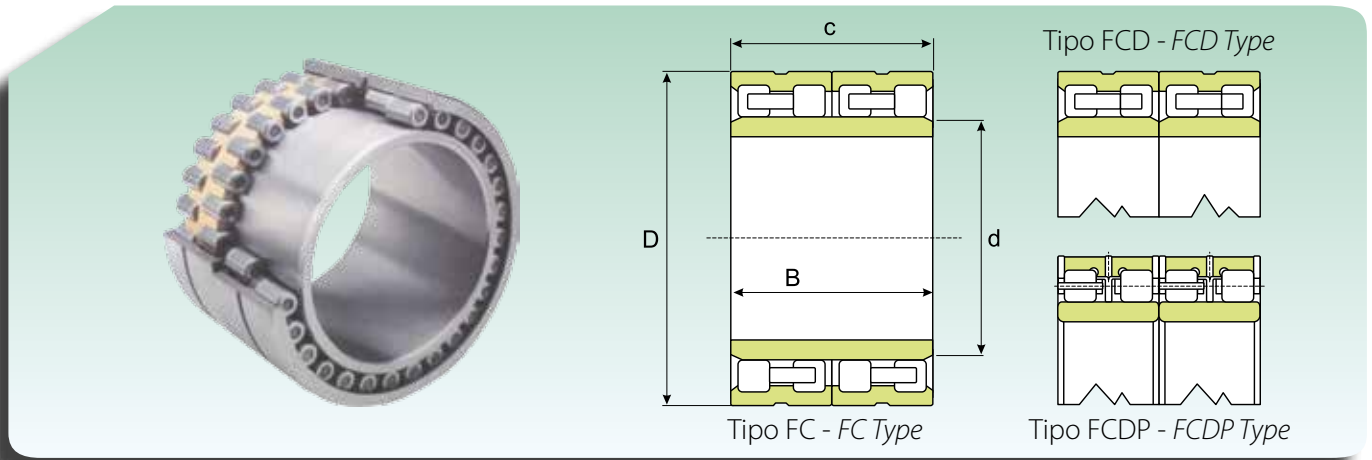
**RODAMIENTOS DE CUATRO HILERAS DE RODILLOS CILÍNDRICOS
CYLINDRICAL ROLLER BEARINGS, FOUR-ROW**

Dimensiones (mm) Dimension (mm)				Coeficiente de carga (KN) Load rating (KN)		Peso (Kg) Weight (Kg)	Sigla Designation
d (mm)	D (mm)	B (mm)	c (mm)	Dinámico Dynamic C	Estático Static C ₀		
260	370	200	200	2050	4250	73.0	FC 5274200
	370	220	220	2100	4900	80.0	FC 5274220
	370	220	220	2100	4800	78.7	FC 5274220A
	400	145	145	1800	1720	136	FCD 5280290
270	380	230	230	1890	4800	80.2	FC 5476230
280	390	220	220	2130	5150	86.5	FC 5678220
	390	240	240	2570	5850	90.4	FC 5678240
	420	280	280	3500	7000	139	FC 5684280
300	420	240	240	3450	6300	111	FC 6084240
	420	300	300	3550	6800	129	FCD 6084300
320	450	240	240	2760	6720	119	FC 6490240
	460	340	340	3700	10000	189	FCD 6492340
330	460	340	340	3550	9950	210	FCD 6692340
340	450	250	250	2430	6800	111	FC 6890250
	480	350	350	3750	10600	202	FCD 6896350
350	500	410	410	5800	13500	280	FCDP 70100410
	520	300	300	4200	9000	213	FC 70104300
360	500	250	250	3600	7730	156	FC 72100250
	510	370	370	4950	11400	220	FCD 72102370
365	540	300	300	5000	11000	490	FC 73108300
370	520	380	380	5230	12000	296	FCDP 74104380
380	540	260	260	3350	8550	198	FCD 76108260
	540	300	300	4650	10100	220	FCD 76108300
	540	304	304	4650	10100	227	FC 76108304
	540	340	340	5240	11900	256	FC 76108340
	540	400	400	5050	14200	297	FCD 76108400
	560	300	300	4950	9650	261	FCD 76112300
	560	325	325	4840	10000	263	FCD 76112325
390	540	320	320	5200	12000	228	FCD 78108320
400	550	300	300	4460	5050	223	FC 80110300
	560	300	300	4550	10000	242	FC 80112300
	560	410	410	6250	15600	310	FCD 80112410
	590	440	440	7250	1650	530	FCD 80114440
410	560	400	400	6400	15800	287	FCDP 82112400
	600	440	440	6450	18300	445	FCDP 82120440
420	580	260	260	4350	9600	205	FCD 84116260
	580	320	320	4680	10800	249	FCD 84116320
	600	440	440	5550	16300	414	FCD 84120440
440	620	450	450	7420	15800	452	FCDP 88124450
	650	355	355	6250	14600	400	FC 88130355
	660	340	340	6380	13500	425	FC 88132340

RODAMIENTOS DE CUATRO HILERAS DE RODILLOS CILÍNDRICOS
CYLINDRICAL ROLLER BEARINGS, FOUR-ROW

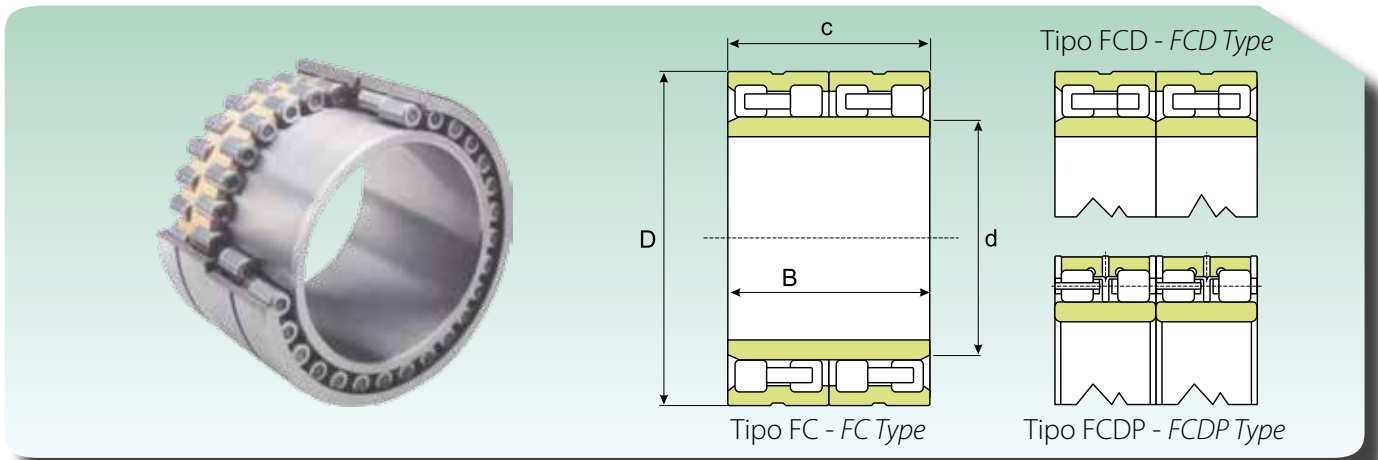

Dimensiones (mm) Dimension (mm)				Coeficiente de carga (KN) Load rating (KN)		Peso (Kg) Weight (Kg)	Sigla Designation
d (mm)	D (mm)	B (mm)	c (mm)	Dinámico Dynamic C	Estático Static C ₀		
450	590	300	300	3900	12200	240	FC 90114300
460	650	355	355	6250	14500	375	FCD 92130355
	650	424	424	7800	18200	452	FCD 92130424
	650	470	470	8750	22400	512	FCD 92130470
	680	400	400	8050	17400	630	FC 92136400
480	650	450	450	7840	15400	419	FCD 96130450
	680	420	420	8400	19400	510	FCD 96136420
	680	500	500	7980	23400	599	FCDP 96136500
500	650	260	260	4000	10000	220	FCD 100130260
	670	450	450	8000	21500	455	FCD 100132450
	680	450	450	8200	22000	485	FCD 100136450
	710	480	480	8780	21500	604	FCDP 100142480
	720	400	400	7850	17500	526	FC 100144400
	738	500	500	10500	23000	732	FCD 100148500
510	680	500	500	8950	26200	525	FCDP 102136500
	730	520	520	9480	21500	744	FCD 102146520
	760	550	550	12000	26500	947	FCDP 102152550
530	760	520	520	11500	28500	773	FCDP 106152520
	780	500	500	9300	20500	810	FCD 106156500
	780	570	570	12700	32500	954	FCD 106156570
550	740	510	510	10000	27500	612	FCDP 110148510
	800	520	520	10300	28500	890	FCDP 110160520
560	800	600	600	13000	33500	1010	FCDP 112160600
	820	315	279	13500	36000	1164	FCDP 112164630
	820	600	600	14200	34000	1075	FCDP 112164600
	820	630	630	14400	36000	1170	FCDP 112164630H
570	750	530	530	9000	26600	625	FC 114150530
	800	514	514	11000	29000	835	FCDP 114160514
	815	594	594	13000	35200	1010	FCDP 114163594
580	780	520	486	9900	27000	696	FCDP 116156486
	780	521	486	9900	27000	700	FCDP 116156486
	780	558	486	9900	27000	713	FCDP 116156486
590	820	590	590	12800	35100	990	FCDP 118164590
600	820	575	575	12300	35000	945	FCDP 120164575
	870	540	540	13000	31500	1100	FCDP 120174540
	870	640	640	13200	38500	1347	FCDP 120174640
630	800	360	360	6850	19500	560	FCD 126160360
	850	436	436	7450	23500	720	FCD 126170436
	920	515	515	13700	17160	1182	FCD 126184515
640	880	600	600	13500	40000	1120	FCDP 128176600
650	900	650	650	14000	42000	1275	FCDP 130180650
	920	670	670	14300	44500	1460	FCDP 130184670
	920	690	690	14500	45000	1490	FCDP 130184690

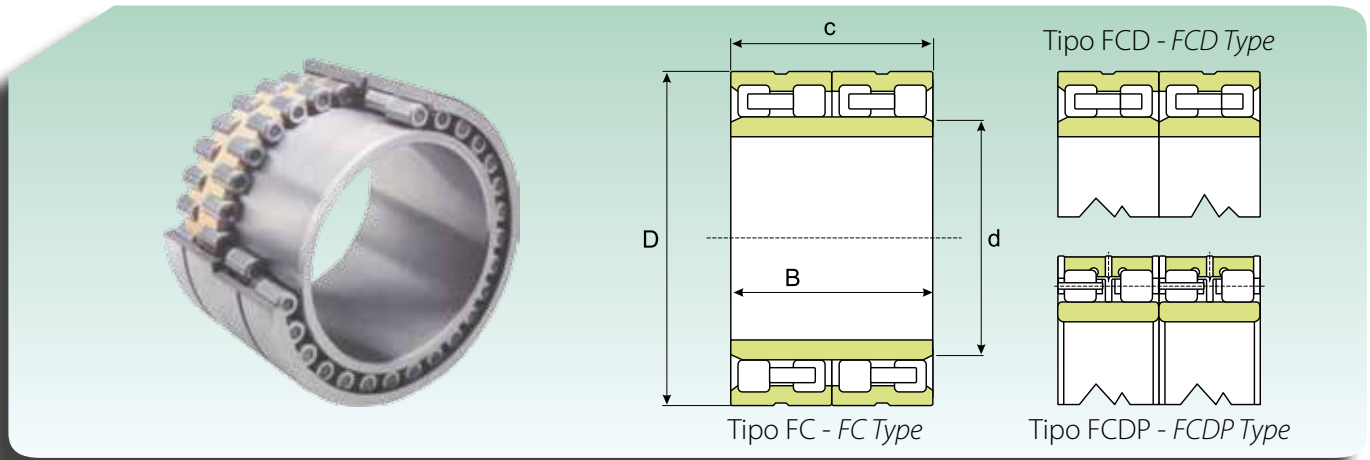
**RODAMIENTOS DE CUATRO HILERAS DE RODILLOS CILÍNDRICOS
CYLINDRICAL ROLLER BEARINGS, FOUR-ROW**

Dimensiones (mm) Dimension (mm)				Coeficiente de carga (KN) Load rating (KN)		Peso (Kg) Weight (Kg)	Sigla Designation
d (mm)	D (mm)	B (mm)	c (mm)	Dinámico Dynamic C	Estático Static C ₀		
660	820	440	440	7450	22700	532	FCD 132164440
	880	450	450	7500	23500	782	FCD 132176450
680	1020	680	680	20000	49500	2050	FCDP 136204680
690	980	715	715	18800	51500	1805	FCDP 138196715
	980	750	750	18800	51500	1920	FCDP 138196750
700	930	620	620	15000	42800	1170	FCDP 140186620
	980	700	700	17500	48500	1680	FCDP 140196700
	1000	710	710	19000	47500	1820	FCDP 140200710
710	1020	710	710	19500	49700	1940	FCDP 142204710
725	1000	700	700	18000	49500	1750	FCDP 145200700
730	960	620	620	15400	45000	1218	FCDP 146192620
	1030	750	750	20500	58500	2035	FCDP 146206750
750	1000	670	670	17000	48500	1522	FCDP 150200670
	1080	665	650	19500	48000	2020	FCDP 150216650
	1090	750	750	21500	51500	2410	FCDP 150218750
	1133	670	670	21000	50500	2450	FCDP 150226670
760	1015	700	700	18500	55000	1600	FCDP 152203700
	1030	750	750	21000	61200	1870	FCDP 152206750
	1080	790	790	23500	65000	2420	FCDP 152216790
	1080	805	790	23500	65000	2450	FCDP 152216790
780	1070	780	780	22000	60000	2280	FCDP 156214780
800	1080	700	700	18800	48500	1850	FCDP 160216700
	1080	750	750	20000	60000	2030	FCDP 160216750
820	1130	800	800	19700	67000	2534	FCDP 164226800
	1160	840	840	21600	68500	2750	FCDP 164232840
840	1160	840	840	24700	70800	2730	FCDP 168232840
850	1150	840	840	25400	76500	2560	FCDP 170230840
	1180	650	650	19000	50500	2100	FCDP 170236650
	1180	850	850	26100	74000	2920	FCDP 170236850
	1180	875	850	26100	74000	2650	FCDP 170236850
860	1140	750	750	20500	61000	2100	FCDP 172228750
	1160	735	710	21000	60000	2150	FCDP 172232710
880	1140	80	800	24000	76000	2210	FCDP 176228800
900	1220	840	840	26300	80000	3050	FCDP 180244840
	1280	780	780	28500	80500	3250	FCDP 180256780
	1280	930	930	32500	93500	4050	FCDP 180256930
	1280	1050	840	28900	80500	3890	FCDP 180256840
920	1280	815	800	28700	80000	3280	FCDP 184256800
	1280	865	850	27600	77500	3450	FCDP 184256850
	1300	975	950	32500	92500	4180	FCDP 184268950

RODAMIENTOS DE CUATRO HILERAS DE RODILLOS CILÍNDRICOS
CYLINDRICAL ROLLER BEARINGS, FOUR-ROW

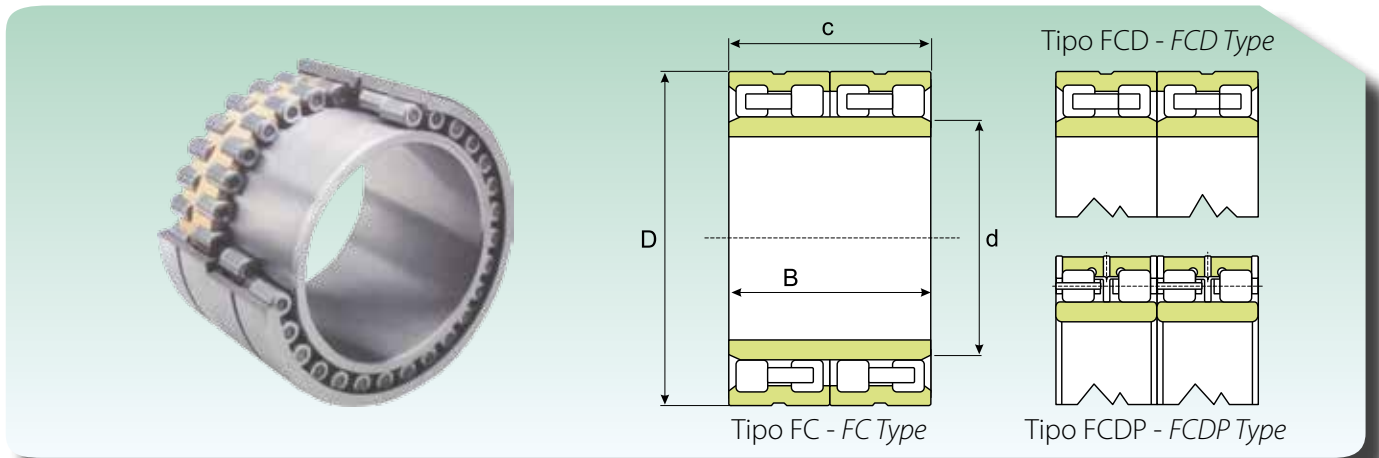

Dimensiones (mm) Dimension (mm)				Coeficiente de carga (KN) Load rating (KN)		Peso (Kg) Weight (Kg)	Sigla Designation
d (mm)	D (mm)	B (mm)	c (mm)	Dinámico Dynamic C	Estático Static C ₀		
950	1300	850	850	32200	85000	3390	FCDP 190260850
	1360	975	975	34000	100000	4895	FCDP 190272975
	1360	1000	1000	37500	105000	5013	FCDP 1902721000
980	1310	880	800	28500	86500	3300	FCDP 196262880
1000	1360	800	800	27000	82800	3560	FCDP 200272800
1030	1380	850	850	29000	90500	3650	FCDP 206276850
1040	1440	1000	1000	37900	93500	5090	FCDP 2082881000
1200	1590	1050	1050	41800	13500	5980	FCDP 2403181050
1300	1655	890	880	37300	122000	4800	FCDP 260331880
1350	1765	1360	1360	40000	122000	9110	FCDP 2703531360
1400	1780	1200	1200	52300	163000	7380	FCDP 2703561200
	1900	1360	1360	61500	182000	11300	FCDP 2703801360





Rodamientos de rodillos cónicos, serie métricas y en pulgadas

Tapered roller bearings, metric and inches series

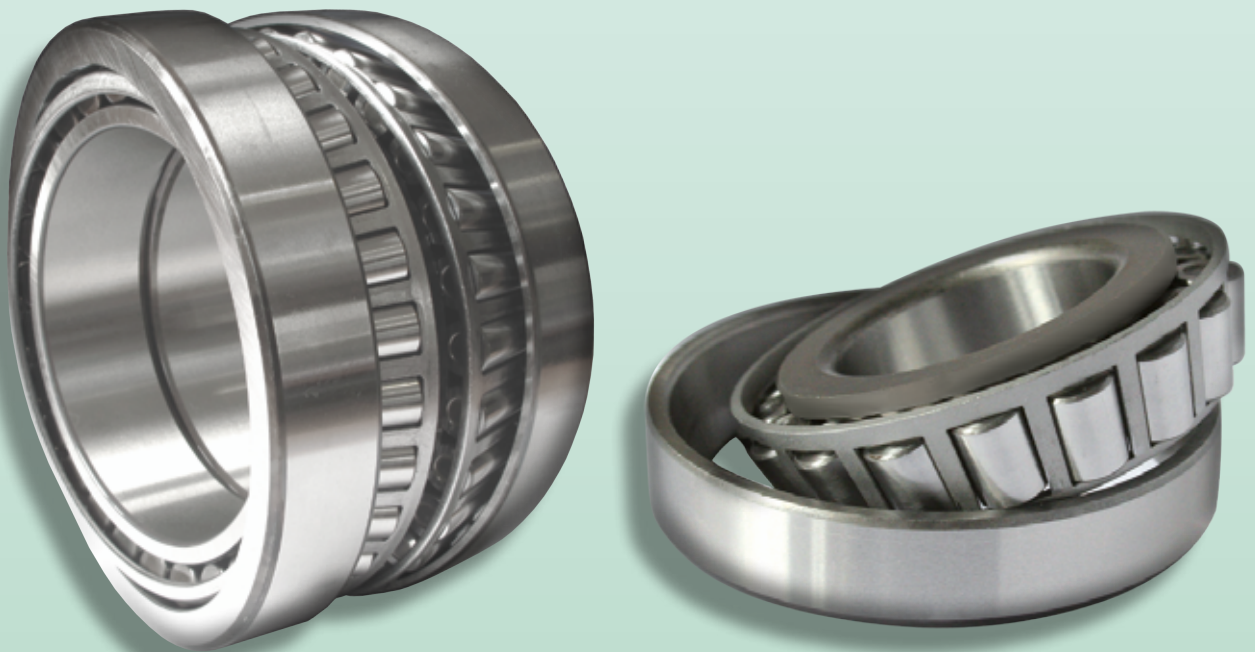

RODAMIENTOS DE UNA HILERA DE RODILLOS CÓNICOS

Los rodamientos **ISB**® de una hilera de rodillos cónicos tienen caminos de rodadura cónicos tanto en el aro interior como en el exterior entre los que giran a su vez rodillos cónicos (**Fig. 1**). La forma constructiva de los rodamientos **ISB**® de una hilera de rodillos cónicos los hace particularmente idóneos para soportar cargas combinadas radiales y axiales. Los rodamientos de rodillos cónicos suelen ser de diseño desarmable, es decir que el aro interior, con el grupo rodillos y jaula, forman una unidad que puede montarse por separado del aro exterior.

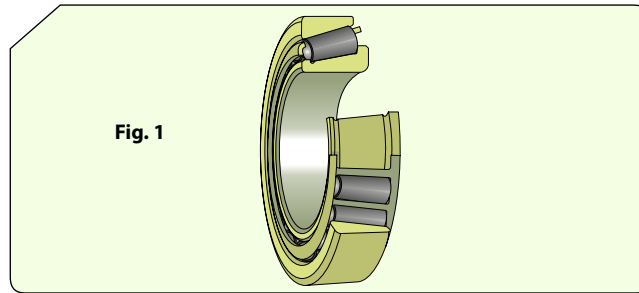

TAPERED ROLLER BEARINGS, SINGLE ROW

ISB® single row tapered roller bearings have tapered raceways on the inner ring and also the outer ring, between which the tapered rollers roll (**Fig. 1**). The constructional design of **ISB**® single row tapered roller bearings makes them particularly suited to withstand combined radial and axial loads. The tapered roller bearings are usually separable, in other words the inner ring and the rollers and cage form a unit that can be fitted separately from the outer ring.

RODAMIENTOS DE UNA HILERA DE RODILLOS CÓNICOS APAREJADOS

Cuando la capacidad de carga ofrecida por un solo rodamiento de rodillos cónicos resulta insuficiente, o cuando el eje debe estar fijado axialmente en ambos sentidos con un determinado juego axial positivo o negativo, se pueden suministrar los rodamientos que se muestran en la sección "Rodamientos de una hilera de rodillos cónicos", como rodamientos (**Fig.2**) y dispuestos cara a cara.

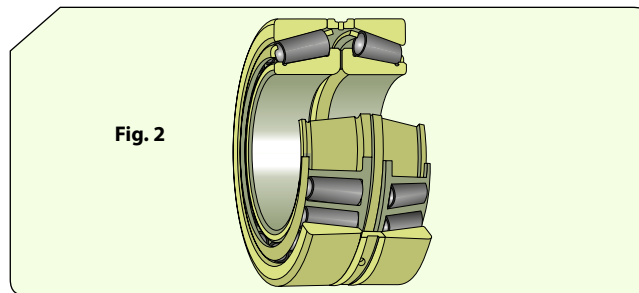

PAIRED SINGLE-ROW TAPERED ROLLER BEARINGS

In systems in which the load capacity of just one tapered roller bearing is not enough or when the shaft must be bound axially in both directions with a certain positive or negative axial clearance, the bearings described in the "single row tapered roller bearings" section can be used, which are available as paired sets (**Fig.2**) and arranged in "X" design.

Las parejas de rodamientos son una solución económica para resolver una variedad de problemas y ofrecen muchas ventajas:

- montaje sencillo
- fijación axial precisa del eje
- elevada capacidad de carga axial y radial
- un mantenimiento sencillo; el lubricante se puede aplicar a través de la ranura anular y los orificios de lubricación localizados en el aro intermedio

DIMENSIONES

Las dimensiones principales de los rodamientos **ISB**® de una hilera de rodillos cónicos métricos respetan la norma ISO 355:1997. Los rodamientos **ISB**® de una hilera de rodillos cónicos en pulgadas siguen las normas ANSI/ABMA 19.2 - 1994.

DESALINEACIÓN

Los rodamientos **ISB**® de una hilera de rodillos cónicos tienen capacidad para tolerar desalineaciones angulares del orden de décimas de milímetros.

The paired sets are an economic solution used to resolve a variety of problems and offer many advantages:

- Simplified assembly
- Exact positioning of the shaft in the axial direction
- High axial and radial load capacity
- Simplified maintenance; the lubricant can be added through the annular groove and the lubrication holes of the intermediate shim

DIMENSIONS

The overall dimensions of the metric **ISB**® single row tapered roller bearings comply with ISO 355:1997. **ISB**® single row tapered roller bearings in inches comply with standards ANSI/ABMA 19.2 - 1994.

MISALIGNMENT

ISB® single row tapered roller bearings are able to tolerate just a very slight angular misalignment (a few arc minutes).

TOLERANCIAS

Los aros interiores con el respectivo grupo de rodillos y jaulas y los aros exteriores de los rodamientos **ISB**[®] de una hilera de rodillos cónicos con la misma designación, son intercambiables. La tolerancia sobre la anchura total B de un rodamiento no se supera cuando se intercambian las copas y los conos. Los rodamientos **ISB**[®] de una hilera de rodillos cónicos, métricos y en pulgadas, se fabrican en la clase de precisión normal.

JUEGO INTERNO

En el caso de rodamientos **ISB**[®] de una hilera de rodillos cónicos, el juego interior se logra sólo después del montaje y se determina, en efecto, mediante el ajuste del rodamiento mismo en contraposición con el segundo rodamiento, que tiene la función de bloqueo en el sentido opuesto.

JAULAS

- Para aplicaciones estándares los rodamientos **ISB**[®] de una hilera de rodillos cilíndricos tienen una jaula de chapa moldeada de acero (**Fig. 3a**);
- para aplicaciones especiales se suministran con jaula moldeada en poliamida 6.6 (**Fig. 3b**). Este tipo concreto de rodamiento puede trabajar a una temperatura de hasta +120°C, con la excepción de algunos aceites sintéticos y grasas con aceite de base sintética.

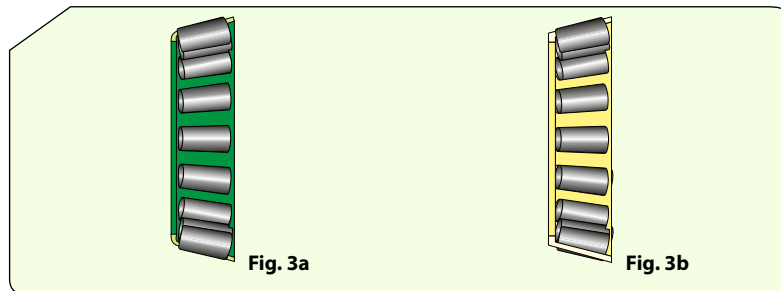

CARGA MÍNIMA

Los rodamientos **ISB**[®] de una hilera de rodillos cónicos están sujetos a una cierta carga mínima sobre todo si giran a velocidades elevadas. En este caso, las fuerzas de inercia de los rodillos y de las jaulas, así como también la fricción del lubricante, pueden influir negativamente sobre las condiciones de rodadura dentro del rodamiento y pueden provocar deslizamientos perjudiciales entre los rodillos y los caminos de rodadura.

DESIGNACIONES SUPLEMENTARIAS

- B** Ángulo de contacto mayor que el del diseño estándar
- J** Jaula moldeada de chapa de acero del tipo de ventanas, centrada en los rodillos. La cifra que sigue la J indica un diseño diverso de jaula
- P6** Mayor precisión dimensional y de rotación según la clase de tolerancia 6 de la norma ISO
- TN9** Jaula moldeada por inyección, diseño de montaje a presión, en poliamida 6.6 con refuerzo de fibra de vidrio, centrada en las bolas
- X** Dimensiones generales modificadas para lograr la conformidad con las normas ISO
- DF** Rodamientos colocado cara a cara

TOLERANCES

The inner rings with respective rollers and cage assembly and the outer rings of **ISB**[®] single row tapered roller bearings with the same designation are interchangeable. The total abutment width tolerance B of a bearing will not be exceeded if the cones and cups are interchanged. **ISB**[®] single row tapered roller bearings (both metric and in inches) are manufactured in the Normal precision class.

INTERNAL CLEARANCE

In the case of **ISB**[®] single row tapered roller bearings, the internal clearance can only be obtained after assembly and it is indeed determined by the adjustment of the bearing itself against a second bearing, which provides location in the opposite direction.

CAGES

- For standard applications, **ISB**[®] single row tapered roller bearings have a pressed sheet steel cage (**Fig. 3a**).
- For special applications, they are supplied with pressed cage made of polyamide 6.6 (**Fig. 3b**). This specific type of bearing can work at temperatures up to + 120°C, with the exception of some synthetic oil and synthetic oil-based grease.

MINIMUM LOAD

ISB[®] single row tapered roller bearings must always be subjected to a given minimum load, especially if they work at high speeds. In this case, the forces of inertia of the rollers and cages and the friction of the lubricant may have a detrimental effect on the rolling conditions within the bearing and could cause harmful contact between rollers and raceways.

SUPPLEMENTARY DESIGNATIONS

- B** Greater contact angle than standard version
- J** Pressed window-type sheet steel cage, centred on the rollers. The figure after J stands for a different cage design
- P6** Greater dimensional and rotation precision, compliant with tolerance class 6 of standard ISO
- TN9** Injection moulded snap-type cage made of polyamide 6.6 with fibreglass reinforcement, centred on the balls
- X** Overall dimensions modified to comply with ISO standards
- DF** Paired bearings arranged in "X" design

CLASES DE PRECISIÓN

Los rodamientos **ISB® ELECTRICAL MOTORS STANDARD**, de una hilera de rodillos cónicos, se fabrican con tolerancias de mecanizado conformes con las normas ISO. Generalmente se fabrican con clase de precisión 6.

A petición del Cliente o para aplicaciones especiales, se pueden suministrar con una clase de precisión superior.

PRECISION CLASS

ISB® ELECTRICAL MOTORS STANDARD, single row tapered roller bearings are manufactured with precision class tolerances in accordance with ISO requirements. They can, at Customers request or for special applications, be supplied with a precision class higher than 6.

CLASE DE PRECISIÓN P0 (ABEC-1)

PRECISION CLASS P0 (ABEC-1)

ARO INTERIOR / INNER RING

μm.

d (mm)		Δ_{dmp}		V_{dp}	V_{dmp}	K_{ia}
más de over	hasta up to	máx	mín	máx	máx	máx
-	10	0	-12	12	9	15
10	18	0	-12	12	9	15
18	30	0	-12	12	9	18
30	50	0	-12	12	9	20
50	80	0	-15	15	11	25
80	120	0	-20	20	15	30
120	180	0	-25	25	19	35
180	250	0	-30	30	23	50
250	315	0	-35	35	26	60
315	400	0	-40	40	30	70
400	500	0	-45	45	34	80
500	630	0	-60	60	40	90
630	800	0	-75	75	45	100
800	1 000	0	-100	100	55	115
1 000	1 250	0	-125	125	65	130
1 250	1 600	0	-160	160	80	150
1 600	2 000	0	-200	200	100	170

ARO EXTERIOR / OUTER RING

μm.

D (mm)		Δ_{Dmp}		V_{Dp}	V_{Dmp}	K_{ea}
más de over	hasta up to	máx	mín	máx	máx	máx
-	18	0	-12	12	9	18
18	30	0	-12	12	9	18
30	50	0	-14	14	11	20
50	80	0	-16	16	12	25
80	120	0	-18	18	14	35
120	150	0	-20	20	15	40
150	180	0	-25	25	19	45
180	250	0	-30	30	23	50
250	315	0	-35	35	26	60
315	400	0	-40	40	30	70
400	500	0	-45	45	34	80
500	630	0	-50	60	38	100
630	800	0	-75	80	55	120
800	1 000	0	-100	100	75	140
1 000	1 250	0	-125	130	90	160
1 250	1 600	0	-160	170	100	180
1 600	2 000	0	-200	210	110	200
2 000	2 500	0	-250	265	120	220

CLASE DE PRECISIÓN P6 (ABEC-3)

Las tolerancias del diámetro del aro interior y del aro exterior de esta clase de precisión son las mismas de la clase P0 (ABEC-1).

PRECISION CLASS P6 (ABEC-3)

The diameter tolerance for inner and outer rings of this precision class are the same of the class P0 (ABEC-1).

CLASE DE PRECISIÓN P5 (ABEC-5)

PRECISION CLASS P5 (ABEC-5)

ARO INTERIOR / INNER RING

μm.

d (mm)		Δ_{dmp}		V_{dp}	V_{dmp}	K_{ia}	S_d
más de over	hasta up to	máx	mín	máx	máx	máx	máx
-	10	0	-7	5	5	5	7
10	18	0	-7	5	5	5	7
18	30	0	-8	6	5	5	8
30	50	0	-10	8	5	6	8
50	80	0	-12	9	6	7	8
80	120	0	-15	11	8	8	9
120	180	0	-18	14	9	11	10
180	250	0	-22	17	11	13	11
250	315	0	-25	19	13	13	13
315	400	0	-30	23	15	15	15
400	500	0	-35	28	17	20	17
500	630	0	-40	35	20	25	20
630	800	0	-50	45	25	30	25
800	1 000	0	-60	60	30	37	30
1 000	1 250	0	-75	75	37	45	40
1 250	1 600	0	-90	90	45	55	50

ARO EXTERIOR / OUTER RING

μm.

D (mm)		Δ_{Dmp}		V_{Dp}	V_{Dmp}	K_{ea}	S_D
más de over	hasta up to	máx	mín	máx	máx	máx	máx
-	18	0	-8	6	5	6	8
18	30	0	-8	6	5	6	8
30	50	0	-9	7	5	7	8
50	80	0	-11	8	6	8	8
80	120	0	-13	10	7	10	9
120	150	0	-15	11	8	11	10
150	180	0	-18	14	9	13	10
180	250	0	-20	15	10	15	11
250	315	0	-25	19	13	18	13
315	400	0	-28	22	14	20	13
400	500	0	-33	26	17	24	17
500	630	0	-38	30	20	30	20
630	800	0	-45	38	25	36	25
800	1 000	0	-60	50	30	43	30
1 000	1 250	0	-80	65	38	52	38
1 250	1 600	0	-100	90	50	62	50
1 600	2 000	0	-125	120	65	73	65

CLASE DE PRECISIÓN P4 (ABEC-7)
PRECISION CLASS P4 (ABEC-7)
ARO INTERIOR / INNER RING

μm.

d (mm)		Δ _{dmp}		V _{dp}	V _{dmp}	K _{ia}	S _d	S _{ia}
más de over	hasta up to	máx	mín	máx	máx	máx	máx	máx
-	10	0	-5	4	4	3	3	3
10	18	0	-5	4	4	3	3	3
18	30	0	-6	5	4	3	4	4
30	50	0	-8	6	5	4	4	4
50	80	0	-9	7	5	4	5	4
80	120	0	-10	8	5	5	5	5
120	180	0	-13	10	7	6	6	7
180	250	0	-15	11	8	8	7	8
250	315	0	-18	12	9	9	8	9

ARO EXTERIOR / OUTER RING

μm.

D (mm)		Δ _{Dmp}		V _{Dp}	V _{Dmp}	K _{ea}	S _D ^a S _{D1}	S _{ea} ^a	S _{ea1}
más de over	hasta up to	máx	mín	máx	máx	máx	máx	máx	máx
-	18	0	-6	5	4	4	4	5	7
18	30	0	-6	5	4	4	4	5	7
30	50	0	-7	5	5	5	4	5	7
50	80	0	-9	7	5	5	4	5	7
80	120	0	-10	8	5	6	5	6	8
120	150	0	-11	8	6	7	5	7	10
150	180	0	-13	10	7	8	5	8	11
180	250	0	-15	11	8	10	7	10	14
250	315	0	-18	14	9	11	8	10	14
315	400	0	-20	15	10	13	10	13	18

ANCHO - AROS INTERIORES, AROS EXTERIORES, RODAMIENTOS Y SUBUNIDADES DE UNA HILERA DE BOLAS

WIDTH - INNER RINGS, OUTER RINGS, SINGLE ROW BEARINGS AND SINGLE ROW SUBUNITS

REFERENCIA CLASE DE PRECISIÓN P0 (ABEC-1) / REFERENCE PRECISION CLASS P0 (ABEC-1)

d (mm)		Δ_{Bs}		Δ_{Cs}		Δ_{Ts}		Δ_{T1s}		Δ_{T2s}	
más de over	hasta up to	máx	mín	máx	mín	máx	mín	máx	mín	máx	mín
-	10	0	-120	0	-120	200	0	100	0	100	0
10	18	0	-120	0	-120	200	0	100	0	100	0
18	30	0	-120	0	-120	200	0	100	0	100	0
30	50	0	-120	0	-120	200	0	100	0	100	0
50	80	0	-150	0	-150	200	0	100	0	100	0
80	120	0	-200	0	-200	200	-200	100	-100	100	-100
120	180	0	-250	0	-250	350	-250	150	-150	200	-100
180	250	0	-300	0	-300	350	-250	150	-150	200	-100
250	315	0	-350	0	-350	350	-250	150	-150	200	-100
315	400	0	-400	0	-400	400	-400	200	-200	200	-200
400	500	0	-450	0	-450	450	-450	225	-225	225	-225
500	630	0	-500	0	-500	500	-500	-	-	-	-
630	800	0	-750	0	-750	600	-600	-	-	-	-
800	1000	0	-1000	0	-1000	750	-750	-	-	-	-
1000	1250	0	-1250	0	-1250	900	-900	-	-	-	-
1250	1600	0	-1600	0	-1600	1050	-1050	-	-	-	-
1600	2000	0	-2000	0	-2000	1200	-1200	-	-	-	-

REFERENCIA CLASE DE PRECISIÓN P6 (ABEC-3) / REFERENCE PRECISION CLASS P6 (ABEC-3)

μm.

d (mm)		Δ_{Bs}		Δ_{Cs}		Δ_{Ts}		Δ_{T1s}		Δ_{T2s}	
más de over	hasta up to	máx	mín	máx	mín	máx	mín	máx	mín	máx	mín
-	10	0	-50	0	-100	100	0	50	0	50	0
10	18	0	-50	0	-100	100	0	50	0	50	0
18	30	0	-50	0	-100	100	0	50	0	50	0
30	50	0	-50	0	-100	100	0	50	0	50	0
50	80	0	-50	0	-100	100	0	50	0	50	0
80	120	0	-50	0	-100	100	0	50	0	50	0
120	180	0	-50	0	-100	150	0	50	0	100	0
180	250	0	-50	0	-100	150	0	50	0	100	0
250	315	0	-50	0	-100	200	0	100	0	100	0
315	400	0	-50	0	-100	200	0	100	0	100	0
400	500	0	-50	0	-100	200	0	100	0	100	0

REFERENCIA CLASE DE PRECISIÓN P5 (ABEC-5) / REFERENCE PRECISION CLASS P5 (ABEC-5)

μm.

d (mm)		Δ _{Bs}		Δ _{Cs}		Δ _{Ts}		Δ _{T1s}		Δ _{T2s}	
más de over	hasta up to	máx	mín	máx	mín	máx	mín	máx	mín	máx	mín
-	10	0	-200	0	-200	200	-200	100	-100	100	-100
10	18	0	-200	0	-200	200	-200	100	-100	100	-100
18	30	0	-200	0	-200	200	-200	100	-100	100	-100
30	50	0	-240	0	-240	200	-200	100	-100	100	-100
50	80	0	-300	0	-300	200	-200	100	-100	100	-100
80	120	0	-400	0	-400	200	-200	100	-100	100	-100
120	180	0	-500	0	-500	350	-250	150	-150	200	-100
180	250	0	-600	0	-600	350	-250	150	-150	200	-100
250	315	0	-700	0	-700	350	-250	150	-150	200	-100
315	400	0	-800	0	-800	400	-400	200	-200	200	-200
400	500	0	-900	0	-900	450	-450	225	-225	225	-225
500	630	0	-1100	0	-1100	500	-500	-	-	-	-
630	800	0	-1600	0	-1600	600	-600	-	-	-	-
800	1000	0	-2000	0	-2000	750	-750	-	-	-	-
1000	1250	0	-2000	0	-2000	750	-750	-	-	-	-
1250	1600	0	-2000	0	-2000	900	-900	-	-	-	-

REFERENCIA CLASE DE PRECISIÓN P4 (ABEC-7) / REFERENCE PRECISION CLASS P4 (ABEC-7)

μm.

d (mm)		Δ _{Bs}		Δ _{Cs}		Δ _{Ts}		Δ _{T1s}		Δ _{T2s}	
más de over	hasta up to	máx	mín	máx	mín	máx	mín	máx	mín	máx	mín
-	10	0	-200	0	-200	200	-200	100	-100	100	-100
10	18	0	-200	0	-200	200	-200	100	-100	100	-100
18	30	0	-200	0	-200	200	-200	100	-100	100	-100
30	50	0	-240	0	-240	200	-200	100	-100	100	-100
50	80	0	-300	0	-300	200	-200	100	-100	100	-100
80	120	0	-400	0	-400	200	-200	100	-100	100	-100
120	180	0	-500	0	-500	350	-250	150	-150	200	-100
180	250	0	-600	0	-600	350	-250	150	-150	200	-100
250	315	0	-700	0	-700	350	-250	150	-150	200	-100

VIBRACIONES Y RUMOROSIDAD

Los rodamientos **ISB® ELECTRICAL MOTORS STANDARD** de una hilera de rodillos cónicos, se fabrican respetando los valores de rumorosidad y vibración indicados en la columna VE - ZE de las tablas que siguen a continuación.

VIBRATIONS AND NOISE

ISB® ELECTRICAL MOTORS STANDARD single row tapered roller bearings have been manufactured in accordance with the values shown in the column VE - ZE in the tables below.

TABLA TOLERANCIAS DE LAS VIBRACIONES

VIBRATIONS TOLERANCES TABLE

µm/s

d mm	V			V ₁			V ₂			V ₃			VE		
	Bajo Low	Medio Medium	Alto High	Bajo Low	Medio Medium	Alto High	Bajo Low	Medio Medium	Alto High	Bajo Low	Medio Medium	Alto High	Bajo Low	Medio Medium	Alto High
15	310	500	500	220	360	360	150	220	220	100	100	100	150	220	270
17	330	550	550	240	400	400	170	240	240	110	110	110	170	240	290
20	330	550	550	240	400	400	170	240	240	110	110	110	170	240	290
25	360	590	600	280	440	450	210	280	280	120	140	130	210	280	340
30	360	590	600	280	440	450	210	280	280	120	140	130	210	280	340
35	400	640	670	320	480	500	250	320	300	150	180	160	250	320	360
40	440	690	740	360	530	560	280	350	320	170	210	190	280	350	390
45	440	690	740	360	530	560	280	350	320	170	210	190	280	350	390
50	480	750	810	400	600	620	320	400	360	220	260	240	320	400	440
55	480	750	810	400	600	680	320	400	360	220	260	240	320	400	440
60	530	850	1 000	450	680	760	370	460	420	300	330	300	370	460	510

TABLA TOLERANCIAS DE LA RUMOROSIDAD

NOISE TOLERANCES TABLE

dB

d mm	302xx, 322xx				303xx, 323xx			
	Z	Z ₁	Z ₂	ZE	Z	Z ₁	Z ₂	ZE
15	-	-	-	-	56	54	50	52
17	56	54	50	52	58	56	52	54
20	57	55	51	53	61	58	53	55
25	58	56	51	53	64	61	56	58
30	59	56	52	54	67	64	59	61
35	61	58	53	56	68	65	60	62
40	63	60	55	58	69	66	61	64
45	65	62	57	60	69	66	61	64
50	67	64	59	62	71	68	63	66
55	69	66	61	64	74	71	66	68
60	71	68	63	66	77	74	69	71

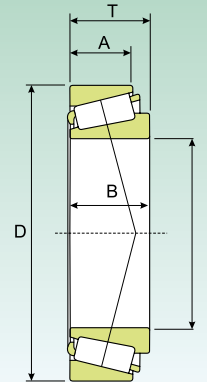
RODAMIENTOS DE UNA HILERA DE RODILLOS CÓNICOS (serie métrica)
TAPERED ROLLER BEARINGS, SINGLE ROW (metric series)

Dimensiones (mm) Dimension (mm)					Coeficiente de carga (KN) Load rating (KN)		Velocidad límite (rpm) Speed limit (Rpm)		Peso (Kg) Weight (Kg)	Sigla Designation
d (mm)	D (mm)	T (mm)	B (mm)	A (mm)	Dinámico Dynamic C	Estático Static C ₀	Lubrificación Lubrication			
							Grasa Grease	Aceite Oil		
15	42	14.25	13	11	22	19	13770	16200	0.095	30302
17	40	13.25	12	11	18	18	13770	16200	0.075	30203
	47	15.25	14	12	27	24	12240	14400	0.13	30303
	47	20.25	19	16	34	32	12240	14400	0.17	32303
20	42	15	15	12	23	26	12240	14400	0.097	32004
	47	15.25	14	12	27	27	11475	13500	0.12	30204
	52	16.25	15	13	33	31	10710	12600	0.17	30304
	52	22.25	21	18	43	44	10710	12600	0.23	32304
22	44	15	15	11.5	24	28	11475	13500	0.1	320/22
25	47	15	15	11.5	26	31	10710	12600	0.11	32005
	52	16.25	15	13	30	32	9945	11700	0.15	30205
	52	19.25	18	15	35	43	9945	11700	0.19	32205
	52	19.25	18	16	35	43	9945	11700	0.19	32205-A
	52	22	22	18	46	54	9945	11700	0.23	33205
	62	18.25	17	15	43	42	9180	10800	0.26	30305
	62	18.25	17	13	37	39	8415	9900	0.26	31305
62	25.25	24	20	59	61	9180	10800	0.36	32305	
28	52	16	16	12	31	37	9945	11700	0.15	320/28
	58	17.25	16	14	37	40	9180	10800	0.25	302/28
	58	20.25	19	16	41	49	9180	10800	0.25	322/28
30	55	17	17	13	35	43	9180	10800	0.17	32006
	62	17.25	16	14	39	43	8415	9900	0.23	30206
	62	21.25	20	13	49	55	8415	9900	0.28	32206
	62	25	25	14	63	75	8415	9900	0.37	33206
	72	20.75	19	17	55	54	7650	9000	0.39	30306
	72	20.75	19	17	46	49	7268	8550	0.39	31306
	72	28.75	27	19.5	75	83	7650	9000	0.55	32306
32	58	17	17	13	36	45	8415	9900	0.19	320/32
35	62	18	18	14	42	52	8415	9900	0.22	32007
	72	18.25	17	15	50	54	7268	8550	0.32	30207
	72	24.25	23	19	64	76	7268	8550	0.43	32207
	72	28	28	22	82	103	7268	8550	0.56	33207
	80	22.75	21	18	70	72	6885	8100	0.52	30307
	80	22.75	21	25	60	65	6503	7650	0.52	31307
	80	32.75	31	25	93	103	6885	8100	0.73	32307
40	68	19	19	14.5	51	69	7268	8550	0.27	32008
	75	26	26	20.5	77	101	6885	8100	0.51	33108
	80	19.75	18	16	60	66	6503	7650	0.42	30208
	80	24.75	23	19	77	84	6503	7650	0.53	32208
	80	32	32	25	102	129	6503	7650	0.77	33208
	90	25.25	23	20	84	93	6120	7200	0.72	30308
	90	25.25	23	17	83	79	5738	6750	0.72	31308
	90	35.25	33	27	114	137	6120	7200	1	32308

RODAMIENTOS DE UNA HILERA DE RODILLOS CÓNICOS (serie métrica)
TAPERED ROLLER BEARINGS, SINGLE ROW (metric series)

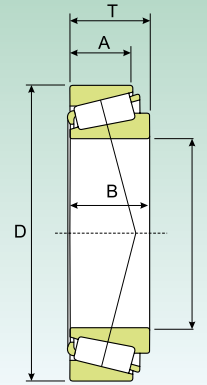

Dimensiones (mm) Dimension (mm)					Coeficiente de carga (KN) Load rating (KN)		Velocidad límite (rpm) Speed limit (Rpm)		Peso (Kg) Weight (Kg)	Sigla Designation
d (mm)	D (mm)	T (mm)	B (mm)	A (mm)	Dinámico Dynamic C	Estático Static C ₀	Lubrificación Lubrication			
							Grasa Grease	Aceite Oil		
45	75	20	20	15.5	57	78	6503	7650	0.34	32009
	80	26	26	20.5	94	111	6120	7200	0.56	33109
	85	20.75	19	16	64	75	6120	7200	0.48	30209
	85	24.75	23	19	89	96	6120	7200	0.58	32209
	85	32	32	25	105	140	5738	6750	0.82	33209
	100	27.25	25	22	105	117	5355	6300	0.97	30309
	100	27.25	25	18	103	100	5126	6030	0.95	31309
100	38.25	36	30	137	166	5355	6300	1.35	32309	
50	80	20	20	15.5	59	86	6120	7200	0.37	32010
	80	24	24	19	67	100	6120	7200	0.45	33010
	85	26	26	20	84	119	5738	6750	0.59	33110
	90	21.75	20	17	75	89	5738	6750	0.54	30210
	90	24.75	23	19	80	98	5738	6750	0.61	32210
	90	32	32	24.5	111	156	5355	6300	0.9	33210
	110	29.25	27	23	140	137	4820	5670	1.25	30310
	110	29.25	27	19	119	117	4590	5400	1.2	31310
110	42.25	40	33	179	211	4590	5400	1.85	32310	
55	90	23	23	17.5	79	113	5355	6300	0.55	32011
	90	27	27	21	101	134	5355	6300	0.67	33011
	95	30	30	23	107	152	5126	6030	0.86	33111
	100	22.75	21	18	101	103	5126	6030	0.7	30211
	100	26.75	25	21	103	126	5126	6030	0.83	32211
	100	35	35	27	135	186	4820	5670	1.2	33211
	120	31.5	29	25	162	159	4284	5040	1.55	30311
	120	31.5	29	21	118	134	4284	5040	1.55	31311
	120	45.5	43	35	211	254	4284	5040	2.5	32311
60	95	27	27	21	103	140	5126	6030	0.71	33012
	100	30	30	23	114	166	4820	5670	0.92	33112
	110	23.75	22	19	109	111	4590	5400	0.88	30212
	110	29.75	28	24	122	156	4590	5400	1.15	32212
	110	38	38	29	164	231	4590	5400	1.6	33212
	130	33.5	31	26	164	192	4055	4770	1.95	30312
	130	33.5	31	22	142	162	4055	4770	1.9	31312
	130	48.5	46	37	224	284	4055	4770	2.85	32312
65	100	23	23	17.5	94	124	4590	5400	0.63	32013
	100	27	27	21	107	149	4820	5670	0.78	33013
	110	34	34	26.5	139	203	4284	5040	1.3	33113
	120	24.75	23	20	129	131	4284	5040	1.15	30213
	120	32.75	31	27	148	189	4284	5040	1.5	32213
	120	41	41	32	190	264	4055	4770	2.05	33213
	140	36	33	28	190	223	3672	4320	2.4	30313
	140	36	33	23	161	189	3672	4320	2.35	31313
	140	51	37	29	241	338	3456	4320	3.45	32313

RODAMIENTOS DE UNA HILERA DE RODILLOS CÓNICOS (serie métrica)
TAPERED ROLLER BEARINGS, SINGLE ROW (metric series)

Dimensiones (mm) Dimension (mm)					Coeficiente de carga (KN) Load rating (KN)		Velocidad límite (rpm) Speed limit (Rpm)		Peso (Kg) Weight (Kg)	Sigla Designation
d (mm)	D (mm)	T (mm)	B (mm)	A (mm)	Dinámico Dynamic C	Estático Static C ₀	Lubrificación Lubrication			
							Grasa Grease	Aceite Oil		
70	110	25	25	19	99	149	4284	5040	0.84	32014
	110	31	31	25.5	127	192	4284	5040	1.1	33014
	120	37	37	29	168	245	4055	4770	1.7	33114
	125	26.25	24	21	122	152	4055	4770	1.25	30214
	125	33.25	31	27	153	203	4055	4770	1.6	32214
	125	41	41	32	197	279	3825	4500	2.1	33214
	150	38	35	30	215	254	3443	4050	2.9	30314
	150	38	35	25	183	215	3443	4050	2.95	31314
150	54	51	42	291	372	3443	4050	4.3	32314	
75	105	20	20	16	69	113	4536	5670	0.52	32915
	115	25	25	19	103	159	4055	4770	0.9	32015
	115	31	31	25.5	131	223	4055	4770	1.15	33015
	125	37	37	29	172	259	3825	4500	1.8	33115
	130	27.25	25	22	137	172	3825	4500	1.4	30215
	130	33.25	31	27	157	207	3825	4500	1.7	32215
	130	41	41	31	204	294	3672	4320	2.25	33215
	160	40	37	31	241	284	3290	3870	3.45	30315
160	40	37	26	204	240	3290	3870	3.5	31315	
80	125	29	29	22	135	211	3825	4500	1.3	32016
	125	36	36	29.5	164	279	3825	4500	1.65	33016
	130	37	37	29	175	274	3672	4320	1.9	33116
	140	28.25	26	22	148	179	3672	4320	1.6	30216
	140	35.25	33	28	183	240	3443	4050	2.05	32216
	140	46	46	35	246	367	3443	4050	2.9	33216
	170	42.5	39	33	264	313	3290	3870	4.1	30316
	170	42.5	39	27	219	259	3060	3600	4.05	31316
170	61.5	58	48	372	490	3290	3870	6.2	32316	
85	130	29	29	22	137	219	3672	4320	1.35	32017
	130	36	36	29.5	179	303	3672	4320	1.75	33017
	140	41	41	32	215	333	3443	4050	2.45	33117
	150	30.5	28	24	172	215	3290	3870	2.05	30217
	150	38.5	36	30	207	279	3290	3870	2.6	32217
	150	49	49	37	280	421	3290	3870	3.7	33217
	180	44.5	41	34	296	357	3060	3600	4.85	30317
	180	44.5	41	28	237	279	2907	3420	4.6	31317
180	63.5	60	49	394	519	3060	3600	6.85	32317	
90	140	32	32	24	164	264	3290	3870	1.75	32018
	140	39	39	32.5	211	347	3443	4050	2.2	33018
	150	45	45	35	246	382	3290	3870	3.1	33118
	160	32.5	30	26	190	240	3060	3600	2.55	30218
	160	42.5	40	34	246	333	3060	3600	3.35	32218
	190	46.5	43	36	323	392	3060	3600	5.65	30318
	190	46.5	43	30	258	308	2601	3060	5.9	31318
	190	67.5	64	53	447	597	3060	3600	8.4	32318

RODAMIENTOS DE UNA HILERA DE RODILLOS CÓNICOS (serie métrica)
TAPERED ROLLER BEARINGS, SINGLE ROW (metric series)

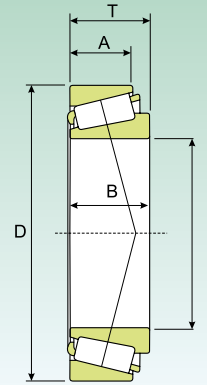

Dimensiones (mm) Dimension (mm)					Coeficiente de carga (KN) Load rating (KN)		Velocidad límite (rpm) Speed limit (Rpm)		Peso (Kg) Weight (Kg)	Sigla Designation	
d (mm)	D (mm)	T (mm)	B (mm)	A (mm)	Dinámico Dynamic C	Estático Static C ₀	Lubrificación Lubrication				
							Grasa Grease	Aceite Oil			
95	145	32	32	24	164	264	3290	3870	1.8	32019	
	145	39	39	32.5	215	367	3290	3870	2.3	33019	
	170	34.5	32	27	211	269	2907	3420	3	30219	
	170	45.5	43	37	275	382	2907	3420	4.05	32219	
	200	49.5	45	38	323	382	2601	3060	6.7	30319	
	200	49.5	45	32	286	347	2601	3060	6.95	31319	
	200	71.5	67	55	491	656	2601	3060	11	32319	
100	140	25	25	20	116	199	3672	4320	1.15	32920	
	150	32	32	24	168	274	3060	3600	1.9	32020	
	150	39	39	32.5	219	382	3060	3600	2.4	33020	
	180	37	34	34	241	313	2754	3240	3.65	30220	
	180	49	46	46	312	431	2754	3240	4.9	32220	
	180	63	63	63	420	641	2754	3240	6.95	33220	
	215	51.5	47	47	394	480	2448	2880	8.05	30320	
	215	56.5	51	51	366	455	2295	2700	8.6	31320	
	215	77.5	73	73	560	764	2295	2700	12.5	32320	
	105	160	35	35	35	197	328	2907	3420	2.4	32021
160		43	43	43	241	421	2907	3420	3.05	33021	
190		39	36	36	264	347	2601	3060	4.25	30221	
190		53	50	50	350	499	2601	3060	6	32221	
225		81.5	77	77	592	798	2295	2700	14.5	32321	
110		150	25	25	25	122	219	3290	3870	1.25	32922
	170	38	38	38	228	382	2754	3240	3.05	32022	
	170	47	47	47	275	490	2754	3240	3.85	33022	
	180	56	56	56	361	617	2601	3060	5.55	30122	
	200	41	38	38	301	396	2448	2880	5.1	30222	
	200	56	53	53	394	558	2448	2880	7.1	32222	
	240	54.5	50	42	463	573	2142	2520	11	30322	
	240	63	57	38	447	573	2142	2520	12	31322	
	240	84.5	80	65	614	813	2142	2520	17	32322	
	120	165	29	29	23	161	298	2907	3420	1.8	32924
180		38	38	29	237	406	2601	3060	3.25	32024	
180		48	48	38	286	529	2601	3060	4.2	33024	
215		43.5	40	34	334	455	2295	2700	6.15	30224	
215		61.5	58	50	458	681	2295	2700	9.15	32224	
260		59.5	55	46	549	695	1989	2340	14	30324	
260		68	62	42	528	681	1836	2160	15.5	31324	
260		90.5	86	69	776	1097	1989	2340	21.5	32324	
130		180	32	32	25	194	357	2754	3240	2.4	32926
		200	45	45	34	307	529	2295	2700	4.95	32026
	230	43.75	40	34	361	480	2142	2520	7.6	30226	
	230	67.75	64	54	539	813	2142	2520	11.5	32226	
	280	63.75	58	49	614	784	1836	2160	17	30326	
	280	72	66	44	592	764	1836	2160	18.5	31326	

RODAMIENTOS DE UNA HILERA DE RODILLOS CÓNICOS (serie métrica)
TAPERED ROLLER BEARINGS, SINGLE ROW (metric series)

Dimensiones (mm) Dimension (mm)					Coeficiente de carga (KN) Load rating (KN)		Velocidad límite (rpm) Speed limit (Rpm)		Peso (Kg) Weight (Kg)	Sigla Designation
d (mm)	D (mm)	T (mm)	B (mm)	A (mm)	Dinámico Dynamic C	Estático Static C ₀	Lubrificación Lubrication			
							Grasa Grease	Aceite Oil		
140	190	32	32	25	200	382	2601	3060	2.55	32928
	210	45	45	34	323	573	2142	2520	5.25	32028
	250	45.75	42	36	409	558	1989	2340	8.65	30228
	250	71.75	68	58	631	980	1989	2340	14.5	32228
	300	77	70	47	679	882	1683	1980	24.5	31328
150	225	48	48	36	361	641	1989	2340	6.35	32030
	225	59	59	46	447	847	1989	2340	8.15	33030
	270	49	45	38	420	548	1836	2160	11	30230
	270	77	73	60	722	1117	1836	2160	17.5	32230
	320	82	75	50	765	999	1530	1800	29.5	31330
160	240	51	51	38	420	764	1836	2160	7.75	32032
	290	52	48	40	517	720	1683	1980	13	30232
	290	84	80	67	862	1372	1683	1980	25.5	32232
	340	75	68	58	894	1156	1530	1800	29	30332
170	230	38	38	30	280	573	2142	2520	4.5	32934
	260	57	57	43	501	896	1683	1980	10.5	32034
	310	57	52	43	603	847	1530	1800	19	30234
	310	91	86	71	989	1597	1530	1800	28.5	32234
180	250	45	45	34	345	720	1989	2340	6.65	32936
	280	64	64	48	631	1136	1683	1980	14.5	32036
	320	57	52	43	571	798	1530	1800	20	30236
	320	91	86	71	989	1597	1454	1710	29.5	32236
190	260	45	45	34	350	749	1836	2160	7	32938
	290	64	64	48	646	1176	1530	1800	15	32038
	340	60	55	46	706	980	1377	1620	24	30238
200	280	51	51	39	463	931	1683	1980	9.5	32940
	310	70	70	53	733	1342	1454	1710	19.5	32040
	360	64	58	48	776	1097	1301	1530	25	30240
	360	104	98	82	1185	1960	1301	1530	42.5	32240
220	300	51	51	39	474	980	1530	1800	10	32944
	340	76	76	57	879	1626	1301	1530	25.5	32044
	400	72	65	54	970	1372	1224	1440	40	30244
	400	114	108	90	1577	2646	1148	1350	60	32244
240	320	51	51	39	501	1058	1454	1710	11	32948
	360	76	76	57	916	1764	1224	1440	27.5	32048
	440	127	120	100	1901	3283	1071	1260	81.5	32248
260	400	87	87	65	1146	2156	1071	1260	40	32052
	480	137	130	106	2156	3577	918	1080	105	32252
	540	113	102	85	2077	2989	918	1080	110	30352
280	380	63.5	63.5	48	749	1626	1224	1440	20	32956
	420	87	87	65	1185	2312	995	1170	40.5	32056

RODAMIENTOS DE UNA HILERA DE RODILLOS CÓNICOS (serie métrica) TAPERED ROLLER BEARINGS, SINGLE ROW (metric series)

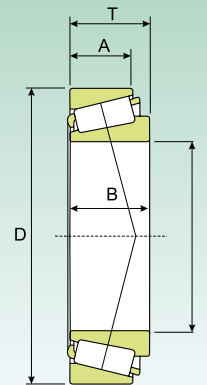

Dimensiones (mm) Dimension (mm)					Coeficiente de carga (kN) Load rating (kN)		Velocidad límite (rpm) Speed limit (Rpm)		Peso (Kg) Weight (Kg)	Sigla Designation
d (mm)	D (mm)	T (mm)	B (mm)	A (mm)	Dinámico Dynamic C	Estático Static C ₀	Lubricación Lubrication			
							Grasa Grease	Aceite Oil		
300	420	76	76	57	1029	2195	1071	1260	32	32960
	460	100	100	74	1509	2940	918	1080	58	32060
	540	149	140	115	2695	4655	842	990	140	32260
320	440	76	76	57	1058	2312	995	1170	33.5	32964
	480	100	100	74	1509	3038	842	990	64	32064
340	460	76	76	57	1058	2352	995	1170	35	32968
360	480	76	76	57	1097	2499	918	1080	37	32972
	530	80	66	59	1030	1900	500	630	53.2	30672
	540	86	82	63.5	1270	2200	480	600	73.1	31072
400	500	60	57	47	460	950	400	500	25.1	30680
	750	130	115	77	2660	4180	320	430	222	30680-1
420	620	95	90	67	1560	2930	380	480	88.3	31084
	620	95	90	67	1560	2940	380	480	88.3	31084P5
460	860	210	190	160	5590	10100	350	470	512	30692
480	950	250	225	174	6980	12500	310	420	761	30696
500	720	110	100	82	2090	4100	360	450	128	T2GB500
530	670	100	95	82	1590	4500	340	450	81.6	318/530
	710	88	82	62	1560	3150	340	450	81.5	319/530
560	1080	265	235	208	8910	15700	180	270	1063	306/560
630	850	132	132	95	3080	7150	360	450	200	329/630
	920	135	128	94	3520	7450	320	430	289	T3GB630
	920	134	128	94	3410	7100	320	430	286	306/630
680	1000	190	188	140	5580	12500	250	350	486	306/680
710	950	114	106	80	2860	6900	230	320	210	319/710
760	890	78	75	59	1360	3520	130	170	78.3	306/760
850	1030	90	88	64	2200	5900	200	300	140	318/850
900	1180	122	122	87	3850	9000	180	260	325	T3GB900
	1280	190	170	135	6430	14600	95	130	71.8	306/900
1000	1420	210	195	150	8100	18000	160	230	966	306/1000
1270	1465	73	69	51	2100	6920	120	170	71.8	306/1270
	1465	100	100	75	3120	10500	120	170	266	306/1270-1

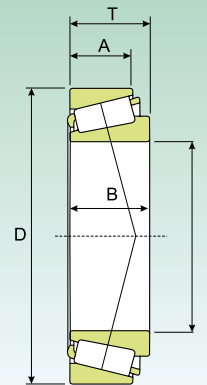
RODAMIENTOS DE UNA HILERA DE RODILLOS CÓNICOS (serie en pulgadas)
TAPERED ROLLER BEARINGS, SINGLE ROW (inches series)

Dimensiones (mm) Dimension (mm)					Coeficiente de carga (KN) Load rating (KN)		Velocidad límite (rpm) Speed limit (Rpm)		Peso (Kg) Weight (Kg)	Sigla Designation
d (mm/in)	D (mm/in)	T (mm/in)	B (mm/in)	A (mm/in)	Dinámico Dynamic C	Estático Static C ₀	Lubrificación Lubrication			
							Grasa Grease	Aceite Oil		
17.462 0.6875	39.878 1.5700	13.843 0.545	27.783 1.0938	23.020 0.9063	20	20	14400	18000	0.08	LM 11749/710
19.050 0.75	45.237 1.7810	15.494 0.61	22.225 0.875	17.462 0.6875	26	26	12960	16200	0.12	LM 11949/910
	49.225 1.9380	18.034 0.71	19.583 0.771	15.875 0.625	38	39	12240	15300	0.17	09067/9195
21.430 0.8437	45.237 1.7810	15.494 0.61	18.288 0.72	13.970 0.55	26	30	12240	15300	0.12	LM 12748/710
	50.005 1.9687	17.526 0.69	19.583 0.771	15.875 0.625	36	37	11520	14400	0.17	M 12649/610
21.986 0.8656	45.237 1.7810	15.494 0.61	25.400 10.000	19.842 0.7812	26	30	12240	15300	0.12	LM 12749/710
	45.974 1.8100	15.494 0.61	24.608 0.9688	19.050 0.75	26	30	12240	15300	0.12	LM 12749/711
22.225 0.875	52.388 2.0625	19.368 0.7625	26.975 10.625	22.225 0.875	40	43	10800	13500	0.20	1380/1328
25.400 1.000	50.292 1.9800	14.224 0.56	28.575 11.250	23.812 0.9375	25	29	10800	13500	0.13	L 44643/610
	50.800 2.000	15.011 0.591	28.575 11.250	23.020 0.9063	27	29	10800	13500	0.13	07100 5/7210 X
	57.150 2.2500	17.462 0.6875	16.764 0.66	11.938 0.47	39	44	9360	11700	0.23	15578/15520
	62.000 2.4409	19.050 0.75	14.732 0.58	10.668 0.42	47	55	8640	10800	0.31	15101/15245
26.157 1.0298	61.912 2.4375	19.050 0.75	14.260 0.5614	12.700 0.5	47	55	8640	10800	0.29	15103 5/15243
	62.000 2.4409	19.050 0.75	17.462 0.6875	13.495 0.5313	47	55	8640	10800	0.29	15103 5/15245
26.988 1.0625	50.292 1.9800	14.224 0.56	19.431 0.765	14.732 0.58	25	29	10800	13500	0.11	L 44649/610
28.575 1.1250	57.150 2.2500	19.845 0.7813	20.638 0.8125	14.288 0.5625	44	49	9360	11700	0.22	1985/1922
	57.150 2.2500	19.845 0.7813	20.638 0.8125	14.288 0.5625	44	49	9360	11700	0.22	1988/1922
	73.025 2.8750	22.225 0.875	20.165 0.7939	15.875 0.625	97	137	7200	9000	1.05	02872/2820
29.000 1.1417	50.292 1.9800	14.224 0.56	19.355 0.762	15.875 0.625	25	31	10080	12600	0.11	L 45449/410
31.750 1.2500	59.131 2.3280	15.875 0.625	22.225 0.875	17.462 0.6875	34	40	8640	10800	0.18	LM 67048/10
	61.912 2.4375	19.050 0.75	14.732 0.58	10.668 0.42	47	55	8640	10800	0.24	15123/15243

RODAMIENTOS DE UNA HILERA DE RODILLOS CÓNICOS (serie en pulgadas)
TAPERED ROLLER BEARINGS, SINGLE ROW (inches series)

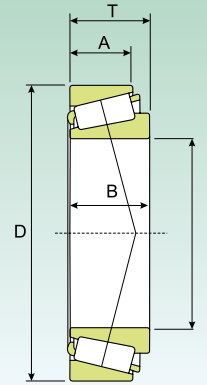

Dimensiones (mm) Dimension (mm)					Coeficiente de carga (KN) Load rating (KN)		Velocidad límite (rpm) Speed limit (Rpm)		Peso (Kg) Weight (Kg)	Sigla Designation
d (mm/in)	D (mm/in)	T (mm/in)	B (mm/in)	A (mm/in)	Dinámico Dynamic C	Estático Static C ₀	Lubrificación Lubrication			
							Grasa Grease	Aceite Oil		
31.750	62.000	19.050	21.433	16.670	47	55	8640	10800	0.24	15123/15245
1.2500	2.4409	0.75	0.8438	0.6563	-	-	-	-	-	-
	73.025	29.370	22.225	17.462	68	93	7200	9000	0.62	HM 88542/510
	2.8750	1.1563	0.875	0.6875	-	-	-	-	-	-
33.338	69.012	19.845	14.288	95.250	52	65	7920	9900	0.35	14131/14276
1.3125	2.7170	0.7813	0.5625	0.375	-	-	-	-	-	-
34.925	65.088	18.034	14.605	10.668	46	55	7920	9900	0.25	LM 48548/510
1.3750	2.5625	0.71	0.575	0.42	-	-	-	-	-	-
	69.012	19.845	16.637	12.065	52	65	7920	9900	0.34	14137 A/14276
	2.7170	0.7813	0.655	0.475	-	-	-	-	-	-
	76.200	29.370	18.288	13.970	84	103	7200	9000	0.63	31594/31520
	3.000	1.1563	0.72	0.55	-	-	-	-	-	-
34.988	59.131	15.875	16.637	12.065	32	43	8640	10800	0.17	L 68149/110
1.3775	2.3280	0.625	0.655	0.475	-	-	-	-	-	-
	59.974	15.875	20.168	14.288	32	43	8640	10800	0.17	L 68149/111
	2.3612	0.625	0.794	0.5625	-	-	-	-	-	-
36.487	73.025	23.812	17.462	12.700	70	86	7200	9000	0.45	25880/25820
1.4365	2.8750	0.9375	0.6875	0.5	-	-	-	-	-	-
38.100	65.088	18.034	19.812	14.732	42	55	7920	9900	0.25	LM 29748/710
1.5	2.5625	0.71	0.78	0.58	-	-	-	-	-	-
	65.088	18.034	19.812	16.604	49	55	7920	9900	0.25	LM 29749/710
	2.5625	0.71	0.78	0.6537	-	-	-	-	-	-
	65.088	19.812	17.384	14.288	42	55	7920	9900	0.25	LM 29749/711
	2.5625	0.78	0.6844	0.5625	-	-	-	-	-	-
	72.238	20.638	23.020	17.462	48	58	7200	9000	0.39	16150/16284
	2.8440	0.8125	0.9063	0.6875	-	-	-	-	-	-
	72.238	23.812	25.654	20.193	48	58	7200	9000	0.39	16150/16283
	2.8440	0.9375	1.0100	0.795	-	-	-	-	-	-
	82.550	29.370	29.370	23.020	84	115	6120	7650	0.78	HM 801346/310
	3.2500	1.1563	1.1563	0.9063	-	-	-	-	-	-
	88.500	26.988	25.400	1.9050	98	111	6480	8100	0.83	418/414
	3.4843	1.0625	1.0000	0.75	-	-	-	-	-	-
39.688	73.025	25.654	25.400	22.225	64	84	7200	9000	0.45	M 201047/11
1.5625	2.8750	1.0100	10.000	0.875	-	-	-	-	-	-
40.988	6.7.75	17.500	24.608	19.050	43	57	7200	9000	0.24	LM 300849/811
1.6137	2.6762	0.689	0.9688	0.75	-	-	-	-	-	-
41.275	73.025	16.667	28.575	23.020	45	54	7200	9000	0.27	18590/18520
1.625	2.8750	0.6562	11.250	0.9063	-	-	-	-	-	-
	73.431	19.558	18.288	13.970	53	66	7200	9000	0.33	LM 501349/310
	2.8910	0.77	0.72	0.55	-	-	-	-	-	-
	73.431	21.430	18.288	15.748	53	66	7200	9000	0.35	LM 501349/314
	2.8910	0.8437	0.72	0.62	-	-	-	-	-	-
	76.200	18.009	18.288	15.748	44	54	6840	8550	0.34	11162/11300

RODAMIENTOS DE UNA HILERA DE RODILLOS CÓNICOS (serie en pulgadas) TAPERED ROLLER BEARINGS, SINGLE ROW (inches series)

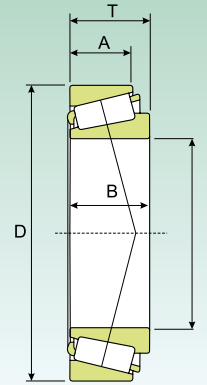

Dimensiones (mm) Dimension (mm)					Coeficiente de carga (KN) Load rating (KN)		Velocidad límite (rpm) Speed limit (Rpm)		Peso (Kg) Weight (Kg)	Sigla Designation
d (mm/in)	D (mm/in)	T (mm/in)	B (mm/in)	A (mm/in)	Dinámico Dynamic C	Estático Static C ₀	Lubrificación Lubrication			
							Grasa Grease	Aceite Oil		
41.275	3.000	0.709	0.72	0.62	-	-	-	-	-	-
1.625	76.200	18.009	20.638	15.875	44	54	6840	8550	0.34	11163/11300
	3.000	0.709	0.8125	0.5625	-	-	-	-	-	-
	76.200	22.225	20.638	19.050	66	84	6840	8550	0.43	24780/24720
	3.000	0.875	0.8125	0.75	-	-	-	-	-	-
	87.312	30.162	29.771	23.812	99.96	129	6120	7650	0.85	3585/3525
	3.4375	1.1875	1.1721	0.9375	-	-	-	-	-	-
	88.900	30.162	28.575	23.020	93	124	5760	7200	0.90	HM 803146/110
	3.5000	1.1875	1.1250	0.9063	-	-	-	-	-	-
	101.600	34.925	29.083	22.225	147	186	5400	6750	1.45	526/52210
	4.000	1.3750	1.1450	0.875	-	-	-	-	-	-
44.450	82.931	23.812	25.400	19.050	79	103	6480	8100	0.57	25580/25520
1.750	3.2650	0.9375	1	0.75	-	-	-	-	-	-
	82.931	26.988	25.400	22.225	79	103	6480	8100	0.57	25580/25523
	3.2650	1.0625	1	0.875	-	-	-	-	-	-
	83.058	23.876	25.400	19.114	79	103	6480	8100	0.57	25580/25522
	3.2700	0.94	1	0.7525	-	-	-	-	-	-
	88.900	30.162	29.370	23.020	93	124	5760	7200	1.50	HM 803149/110
	3.5000	1.1875	1.1563	0.9063	-	-	-	-	-	-
	95.250	30.958	28.300	20.638	86	94	5040	6300	0.93	53178/53377
	3.7500	1.2188	1.142	0.8125	-	-	-	-	-	-
45.237	87.313	30.162	30.886	23.812	99	129	6120	7650	0.85	3586/3525
1.7810	3.4375	1.1875	12.160	0.9375	-	-	-	-	-	-
45.242	73.431	19.558	19.812	15.748	52	73	6840	8550	0.30	LM 102949/910
1.7812	2.8910	0.77	0.7812	0.62	-	-	-	-	-	-
	77.788	19.842	19.842	15.080	52	68	6480	8100	0.37	LM 603049/011
	3.0625	0.7812	0.7812	0.5937	-	-	-	-	-	-
45.618	82.931	23.812	25.400	19.050	79	103	6480	8100	0.55	25590/25520
1.7960	3.2650	0.9375	1.000	0.75	-	-	-	-	-	-
	82.931	26.988	25.400	22.225	79	103	6480	8100	0.55	25590/25523
	3.2500	1.0625	1.000	0.875	-	-	-	-	-	-
	83.058	23.876	25.400	19.114	79	103	6480	8100	0.55	25590/25522
	3.2700	0.94	1.000	0.7525	-	-	-	-	-	-
46.038	79.375	17.462	17.462	13.495	48	60	6480	8100	0.33	18690/18620
1.8105	3.1250	0.6875	0.6875	0.5313	-	-	-	-	-	-
47.625	101.600	34.925	36.068	26.988	147	186	5400	6750	1.25	528 R/522
1.8750	4.000	1.3750	1.4200	1.0625	-	-	-	-	-	-
50.800	82.550	21.590	22.225	16.510	70	98	6120	7650	0.43	LM 104949/911
2.0000	3.250	0.85	0.875	0.65	-	-	-	-	-	-
	85.000	17.462	17.462	13.495	49	64	6120	7650	0.37	18790/18720
	3.3465	0.6875	0.6875	0.5313	-	-	-	-	-	-
	88.900	20.637	22.225	16.513	74	89	5760	7200	0.50	368 A/362 A
	3.500	0.8125	0.875	0.6501	-	-	-	-	-	-
	93.264	30.162	30.302	23.812	107	143	5400	6750	0.85	3780/3720
	3.6718	1.1875	11.930	0.9375	-	-	-	-	-	-

RODAMIENTOS DE UNA HILERA DE RODILLOS CÓNICOS (serie en pulgadas)
TAPERED ROLLER BEARINGS, SINGLE ROW (inches series)

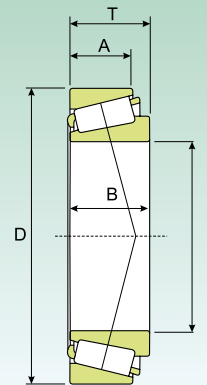

Dimensiones (mm) Dimension (mm)					Coeficiente de carga (KN) Load rating (KN)		Velocidad límite (rpm) Speed limit (Rpm)		Peso (Kg) Weight (Kg)	Sigla Designation
d (mm/in)	D (mm/in)	T (mm/in)	B (mm/in)	A (mm/in)	Dinámico Dynamic C	Estático Static C ₀	Lubrificación Lubrication			
							Grasa Grease	Aceite Oil		
50.800 2.0000	97.630 3.8437	24.608 0.9688	24.608 0.9688	19.446 0.7656	87 -	126 -	5040 -	6300 -	0.83 -	28678/28622 B
	104.775 4.1250	39.688 1.5625	40.157 15.810	33.338 1.3125	153 -	219 -	5040 -	6300 -	1.65 -	4580/2/4535/2
	107.950 4.2500	36.512 1.4375	36.957 14.550	28.575 1.1250	147 -	186 -	5040 -	6300 -	1.55 -	537/532 X
53.975 2.1250	88.900 3.5000	19.050 0.75	19.050 0.75	13.492 0.5313	57 -	76 -	5760 -	7200 -	0.43 -	LM 806649/610
	95.250 3.7500	27.783 1.0938	28.575 1.1250	22.225 0.875	102 -	134 -	5400 -	6750 -	0.80 -	33895/33821
	95.250 3.7500	27.783 1.0938	28.575 1.1250	22.225 0.875	102 -	134 -	5400 -	6750 -	0.80 -	33895/33822
57.150 2.2500	96.838 3.8125	21.000 0.8268	21.946 0.864	15.875 0.625	79 -	99 -	5400 -	6750 -	0.59 -	387A/382 A
	96.838 3.8129	25.400 0.8268	21.946 0.864	20.274 0.7982	79 -	99 -	5400 -	6750 -	0.58 -	387 A/382 S
	98.425 3.8750	21.000 0.8268	21.946 0.864	17.826 0.7018	79 -	99 -	5400 -	6750 -	0.58 -	387 A/382
	104.775 4.1250	30.162 1.1875	29.317 1.154	24.605 0.9687	118 -	156 -	5040 -	6300 -	1.05 -	462/453 X
	112.712 4.4375	30.162 1.1875	30.162 1.1875	23.812 0.9375	139 -	199 -	4536 -	5670 -	1.45 -	39580/39520
	119.985 4.7238	32.750 1.2894	30.162 1.1874	26.949 1.0610	139 -	199 -	4536 -	5670 -	1.75 -	39580/39528
63.500 2.5000	112.712 4.4375	30.162 1.8175	30.048 1.1830	23.812 0.9375	120 -	179 -	4536 -	5670 -	1.25 -	3982/3920
65.088 2.5625	135.755 5.3447	53.975 2.1250	56.007 2.2050	44.450 1.7500	280 -	392 -	4032 -	5040 -	3.70 -	6379/K6320
66.675 2.6250	112.712 4.4375	30.162 1.8175	30.162 1.1830	23.812 0.9375	139 -	199 -	4536 -	5670 -	1.20 -	39590/39520
	119.985 4.7238	32.750 1.2894	30.162 1.1830	26.949 1.0610	139 -	199 -	4536 -	5670 -	1.20 -	39590/39528
69.850 2.7500	112.712 4.4375	25.400 1.000	25.400 1.000	19.050 0.75	97 -	152 -	4320 -	5400 -	0.97 -	29675/29620/3
	127.000 5.000	36.512 1.4375	36.170 1.4240	28.575 1.1250	172 -	249 -	4032 -	5040 -	1.90 -	566/563
71.438 2.8125	117.475 4.6250	30.162 1.1875	30.162 1.1875	23.81 0.9375	120 -	186 -	4320 -	5400 -	1.25 -	33281/33462
73.025 2.8750	112.712 4.4375	25.400 1.000	25.400 1.000	19.050 0.75	97 -	152 -	4320 -	5400 -	0.89 -	29685/2/29620/3
	117.475 4.6250	30.162 1.1875	30.162 1.1875	23.812 0.9375	120 -	186 -	4320 -	5400 -	1.20 -	33287/33462

RODAMIENTOS DE UNA HILERA DE RODILLOS CÓNICOS (serie en pulgadas)
TAPERED ROLLER BEARINGS, SINGLE ROW (inches series)

Dimensiones (mm) Dimension (mm)					Coeficiente de carga (KN) Load rating (KN)		Velocidad límite (rpm) Speed limit (Rpm)		Peso (Kg) Weight (Kg)	Sigla Designation
d (mm/in)	D (mm/in)	T (mm/in)	B (mm/in)	A (mm/in)	Dinámico Dynamic C	Estático Static C ₀	Lubrificación Lubrication			
							Grasa Grease	Aceite Oil		
76.200 3.000	127.000 5.000	30.162 1.1875	31.000 1.2205	22.225 0.875	135 -	199 -	3816 -	4770 -	1.90 -	42687/42620
	139.992 5.5115	36.512 1.4375	36.098 1.4212	28.575 1.1250	183 -	274 -	3600 -	4500 -	2.45 -	575/572
82.550 3.2500	139.992 5.5115	36.512 1.4375	36.098 1.4212	28.575 1.1250	183 -	274 -	3600 -	4500 -	2.20 -	580/572
	146.050 5.7500	41.275 1.6250	41.275 1.6250	31.750 1.2500	215 -	313 -	3456 -	4320 -	2.80 -	663/653
88.900 3.500	152.400 6.000	39.688 1.5625	36.322 1.4300	30.162 1.1875	190 -	298 -	3240 -	4050 -	2.80 -	593/592 A
92.075 3.625	152.400 6.000	39.688 1.5625	36.322 1.4300	30.162 1.1875	190 -	298 -	3240 -	4050 -	2.70 -	598/592 A
95.250 3.750	146.050 5.7500	33.338 1.3125	34.925 1.3750	26.195 1.0313	164 -	274 -	3240 -	4050 -	1.90 -	47896/47820
	152.400 6.000	39.688 1.5625	36.322 1.4300	30.162 1.1875	190 -	298 -	3240 -	4050 -	2.55 -	594/592 A
101.600 4.000	168.275 6.6250	41.275 1.6250	41.275 1.6250	30.162 1.1875	228 -	357 -	2880 -	3600 -	3.45 -	687/672
114.300 4.500	177.800 7.000	41.275 1.6250	41.275 1.6250	30.162 1.1875	245 -	406 -	2736 -	3420 -	3.60 -	64450/64700
	180.975 7.1250	34.925 1.3750	31.750 1.2500	25.400 1.000	179 -	274 -	2736 -	3420 -	2.95 -	68450/68712
127.000 5.000	182.562 7.1875	39.688 1.5625	38.100 1.5000	33.338 1.3125	224 -	431 -	2592 -	3240 -	3.30 -	48290/48220
	196.850 7.7500	46.038 1.8135	46.038 1.8125	38.100 1.500	312 -	573 -	2448 -	3060 -	5.20 -	67388/67322
133.350 5.250	196.850 7.7500	46.038 1.8135	46.038 1.8125	38.100 1.5000	312 -	573 -	2448 -	3060 -	4.80 -	67391/67322
139.700 5.500	236.538 9.3125	57.150 2.2500	56.642 2.2300	44.450 1.7500	501 -	833 -	2016 -	2520 -	10.00 -	HM 231132/110
158.750 6.250	205.583 8.0938	23.812 0.9375	23.812 0.9374	18.258 0.7188	135 -	274 -	2160 -	2700 -	1.95 -	L 432348/310
	205.583 8.0938	23.812 0.9375	23.812 0.9374	18.258 0.7188	135 -	274 -	2160 -	2700 -	1.95 -	L 432349/310
177.800 7.000	227.012 8.9375	30.162 1.1875	30.162 1.1875	23.020 0.9063	183 -	416 -	2016 -	2520 -	3.00 -	36990/36920
191.237 7.5290	279.400 11.000	52.388 2.0625	58.738 2.3125	41.275 1.6250	512 -	960 -	1584 -	1980 -	9.20 -	M 239448 A/410
196.850 7.7500	241.300 9.5000	2.3812 0.9375	23.017 0.9061	17.462 0.6875	150 -	308 -	1872 -	2340 -	2.00 -	LL 639249/210

RODAMIENTOS DE UNA HILERA DE RODILLOS CÓNICOS (serie en pulgadas)
TAPERED ROLLER BEARINGS, SINGLE ROW (inches series)



Dimensiones (mm) Dimension (mm)					Coeficiente de carga (KN) Load rating (KN)		Velocidad límite (rpm) Speed limit (Rpm)		Peso (Kg) Weight (Kg)	Sigla Designation
d (mm/in)	D (mm/in)	T (mm/in)	B (mm/in)	A (mm/in)	Dinámico Dynamic C	Estático Static C ₀	Lubrificación Lubrication			
							Grasa Grease	Aceite Oil		
216.408 8.5200	285.750 11.2500	46.038 1.8125	49.212 1.9375	34.924 1.3750	372 -	833 -	1584 -	1980 -	7.85 -	LM 742747/710
230.188 9.062	317.500 12.5000	47.625 1.8750	52.388 2.0625	36.512 1.4375	512 -	960 -	1440 -	1800 -	10.50 -	LM 245846/810
231.775 9.1250	317.500 12.5000	47.625 1.8750	52.388 2.0625	36.512 1.4375	512 -	960 -	1440 -	1800 -	10.50 -	LM 245848/810
255.600 10.0630	342.900 13.5000	57.150 2.2500	63.500 2.5000	44.450 1.7500	582 -	1195 -	1296 -	1620 -	14.00 -	M 349547/510
257.175 10.1259	358.775 14.1250	71.438 2.8125	76.200 3.000	53.975 2.1250	825 -	1724 -	1224 -	1530 -	20.50 -	M 249747/710
263.525 10.3750	325.438 12.8125	28.575 1.1250	2.8575 1.1250	25.400 1.000	215 -	539 -	1296 -	1620 -	53.00 -	38880/38820
266.7	355.6 393.7	57.15 73.817	57.15 69.85	44.45 50.005	715 770	800 1460	850 750	1200 1000	15.1 27.8	KLM451349/KLM451310 KEE275105/K275155
273.05	393.7	73.817	69.85	50.005	770	1460	750	1000	26.3	KEE275108/K275155
288.925	406.4	77.788	77.788	60.325	1250	1900	670	900	30.5	M255449/M255410
292.100	374.650	47.625	47.625	34.925	1080	1590	780	1050	12.2	L555249/L555210
304.8	393.7 406.4 546.1	50.8 63.5 171.053	50.8 63.5 171.13	38.1 47.625 140.17	580 2200 520	1210 2800 1210	670 670 560	900 900 750	14.6 21.2 171	KL357049/KL357010 LM757049/LM757010 306/304.8
317.5	447.675	85.725	85.725	68.262	960	2330	670	900	41.3	HM259048/HM259010
330.200	482.600	85.725	80.167	60.325	1200	2480	600	830	49.2	EE526130/526190
333.375	469.900	90.488	90.488	71.438	1320	2820	600	830	47.6	HM261049/HM261010
343.154	450.850	66.675	66.675	52.388	930	2180	650	850	28.3	LM361649A/LM361610
346.075	488.950	95.250	95.250	74.612	845	1180	600	830	55.8	HM262749/HM262710
355.6	482.6	60.320	55.560	38.1	565	1180	600	830	26.6	306/355.6-1
377.825	522.288	85.725	84.138	61.912	1170	2580	670	900	51.9	KLM565946/KLM565910
380.1	480	50	48.08	35.08	590	1490	560	750	20.8	306/380.1
381	497.425 522.288	49.212 85.725	47.625 84.138	34.925 61.912	590 1170	1490 2850	560 650	750 870	20.4 51.2	L865547/L865512 KLM565949/KLM565910
384.175	546.100	104.775	104.775	82.550	1850	4150	530	700	77.6	HM266449/HM266410
403.225	460.375	28.575	28.575	20.638	240	760	560	750	6.73	LL566848/LL566810

RODAMIENTOS DE UNA HILERA DE RODILLOS CÓNICOS (serie en pulgadas) TAPERED ROLLER BEARINGS, SINGLE ROW (inches series)

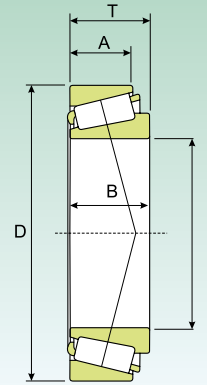

Dimensiones (mm) Dimension (mm)					Coeficiente de carga (KN) Load rating (KN)		Velocidad límite (rpm) Speed limit (Rpm)		Peso (Kg) Weight (Kg)	Sigla Designation
d (mm/in)	D (mm/in)	T (mm/in)	B (mm/in)	A (mm/in)	Dinámico Dynamic C	Estático Static C ₀	Lubrificación Lubrication			
							Grasa Grease	Aceite Oil		
406.4	546.1	76.2	61.12	55.562	840	1830	630	850	41.8	KEE234160/K234215
	549.275	85.725	84.138	61.962	1350	3000	600	800	54.0	LM567949/LM567910
	574.625	76.2	67.866	50.8	920	2030	500	650	54.2	EE285160/EE285226
	762	108.975	161.925	107.950	3650	6050	350	480	322	H969249/H969210
415.925	590.55	114.3	114.3	88.9	1810	4030	480	650	96.9	M268749/M268710
430.212	603.250	76.2	73.025	50.8	1050	2300	480	650	58.6	EE241693/242375
447.625	635	120.650	120.650	95.250	2300	5450	430	560	121	M270749/M270710
457.2	573.088	74.612	74.612	57.150	1100	2980	480	630	43.8	L570649/L570610
	603.250	85.725	84.138	60.325	1420	3390	450	600	62.0	LM770949/LM770910
	615.950	85.725	85.725	66.675	1450	3750	420	580	73.2	LM272235/LM272210
	660.400	91.280	85.725	62.705	1750	3600	420	580	91.5	EE737181/737260
482.6	634.873	80.962	80.962	63.5	1430	3600	420	580	60.8	EE243190/243250
488.95	634.873	84.138	84.138	61.912	1420	3600	420	580	64.5	LM772748/LM772710
498.475	634.873	80.962	80.962	63.5	1340	2950	420	580	58.3	EE243196/243250/HE
520.7	736.6	88.9	81.758	53.975	1630	3350	380	500	101	EE982051/982900
536.575	761.873	146.05	146.05	114.3	3300	7950	360	480	202	M276449/M276410
	820	152	146	112	3850	7750	340	450	273	306/536X4
539.750	635	50.8	50.8	38.1	780	2150	400	530	27.2	LL575349/LL575310
607.72	787.4	93.662	93.662	69.85	2120	5250	340	450	108	EE649239/649310
609.6	787.4	93.662	93.662	69.85	2120	5250	340	450	108	EE649240/649310
635	736.6	57.15	53.975	41.275	855	2640	350	470	37.3	80780/80720
660.4	812.8	95.25	95.25	73.025	1920	5550	310	420	106	L281147/L281110
	939.8	136.525	127.08	98.5	3700	8100	260	360	288	306/660.4
	1000	152.4	142.24	113.665	4300	9450	240	340	411	306/660.4-1
679.45	901.7	142.875	142.875	111.125	3550	8900	260	360	243	LM281849/LM281810
682.625	965.2	185.738	185.810	142.950	5050	12480	240	340	419	306/682 X4-2
	1080	200	195	142	6650	13100	200	300	641	306/682 X4-3
685.8	876.3	93.662	92.075	69.85	2100	4950	280	380	399	EE655270/655345
711.2	939.8	120.65	115.38	73.33	2600	6150	220	320	207	306/711.2
723.9	914.4	84.137	80.962	60.325	2000	4850	260	360	116	EE755285/755360
749.3	990.6	159.5	160.388	123	4500	11800	220	320	331	LM283649/LM283610
759.925	889	69.85	69.85	50.8	1210	3750	260	360	67.2	LL483488/LL483418
760	889	88.9	88.9	72	2200	3200	260	360	93.5	L183448/L183410
762	889	88.9	88.9	72	2200	3200	260	360	91.9	L183449/L183410

RODAMIENTOS DE UNA HILERA DE RODILLOS CÓNICOS (serie en pulgadas)
TAPERED ROLLER BEARINGS, SINGLE ROW (inches series)



Dimensiones (mm) Dimension (mm)					Coeficiente de carga (KN) Load rating (KN)		Velocidad límite (rpm) Speed limit (Rpm)		Peso (Kg) Weight (Kg)	Sigla Designation
d (mm/in)	D (mm/in)	T (mm/in)	B (mm/in)	A (mm/in)	Dinámico Dynamic C	Estático Static C ₀	Lubrificación Lubrication			
							Grasa Grease	Aceite Oil		
774.7	965.2	93.662	80.962	66.675	1920	4850	220	320	130	EE752305/752380
801.688	914.4	58.738	58.738	41.275	1050	3500	240	340	53.6	LL584449/LL584410
838.2	1041.4	93.662	88.9	66.675	1850	4750	200	300	161	EE763330/763410
928	1060	92	90	76	2120	7450	190	280	117	JL286948H/JL286910
930	1060	92	90	76	2120	7450	190	280	115	JL286949H/JL286910
977.9	1130.3	66.675	63.5	47.625	1430	4300	170	240	101	LL687949/LL687910
1016	1270	101.6	101.6	66.675	2700	7450	160	230	276	EE168400/168500

RODAMIENTOS DE UNA HILERA DE RODILLOS CÓNICOS, APAREADOS CARA A CARA TAPERED ROLLER BEARINGS, SINGLE ROW, FACE-TO-FACE

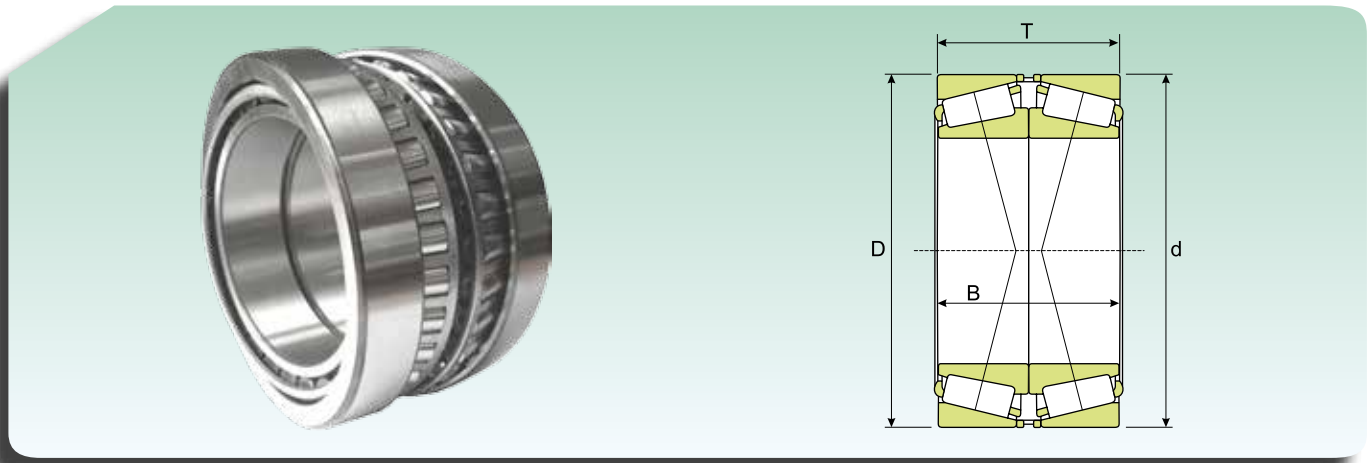

Dimensiones (mm) Dimension (mm)			Coeficiente de carga (KN) Load rating (KN)		Velocidad límite (rpm) Speed limit (Rpm)		Peso (Kg) Weight (Kg)	Sigla Designation
d (mm)	D (mm)	T (mm)	Dinámico Dynamic C	Estático Static C ₀	Lubrificación Lubrication			
					Grasa Grease	Aceite Oil		
25	62	36,5	63,112	78,4	9900	10450	0,55	31305 J/DF
30	72	41,5	79,282	98	8550	9025	0,85	31306 J/DF
35	80	45,5	102,9	131,32	7650	8075	1,10	31307 J/DF
40	90	50,5	143,08	159,74	6750	7125	1,50	31308 J/DF
45	100	54,5	176,4	199,92	6030	6365	2,00	31309 J/CDF
50	90	43,5	127,4	179,34	6750	7125	1,10	30210 J/DF
	110	58,5	203,84	235,2	5400	5700	2,6	31310 J/DF
55	90	54	176,4	264,6	6300	6650	1,35	33011/DF03C170
	120	63	204,82	269,5	5040	5320	3,30	31311 J/DF
60	95	46	159,74	240,1	6030	6365	1,90	32012 X/DFC250
	130	67	241,08	328,3	4770	5035	4,10	31312 J/DF
65	120	49,5	223,44	264,6	5040	5320	1,20	30213 J/DF
	140	72	275,38	372,4	4320	4560	5,05	31313 J/DF
70	110	62	215,6	392	5040	5320	2,40	33014/DF
	150	76	312,62	431,2	4050	4275	6,15	31314 J/DF
75	115	62	228,34	445,9	4770	5035	2,40	33015/DF
	125	74	296,94	519,4	4500	4750	3,80	33115/DFC150
	130	54,5	233,24	347,9	4500	4750	2,85	30215 J/DF
	130	66,5	269,5	416,5	4500	4750	3,40	32215 J/DF
	160	80	350,84	480,2	3870	4085	7,25	31315 J/DF
80	125	58	228,34	421,4	4500	4750	2,65	32016 X/DFC165
	140	70,5	312,62	480,2	4050	4275	4,25	32216 J/DF
	170	85	372,4	519,4	3600	3800	8,75	31316 J1/DF
85	130	58	233,24	441	4320	4560	2,80	32017 X/DF
	130	72	301,84	607,6	4320	4560	3,55	33017/DFC240
	150	61	296,94	431,2	3870	4085	4,30	30217 J/DF
	150	77	361,62	558,6	3870	4085	5,45	32217 J/DF
	150	98	485,1	833	3870	4085	7,35	33217/DF
	180	89	404,74	558,6	3420	3610	10,0	31317 J/DF
90	140	64	286,16	529,2	3870	4085	3,65	32018 X/DF
	140	78	361,62	695,8	4050	4275	4,50	33018/DFC150
	160	65	329,28	480,2	3600	3800	5,15	30218 J/DF
	160	85	420,42	666,4	3600	3800	6,90	32218 J/DF
	190	93	447,86	617,4	3060	3230	11,5	31318 J/DF
95	145	78	372,4	720,3	3870	4085	5,00	33019/DF
	170	91	474,32	764,4	3420	3610	8,45	32219 J/DF
	200	99	490,98	695,8	3060	3230	13,0	31319 J/DF

RODAMIENTOS DE UNA HILERA DE RODILLOS CÓNICOS, APAREADOS CARA A CARA
TAPERED ROLLER BEARINGS, SINGLE ROW, FACE-TO-FACE

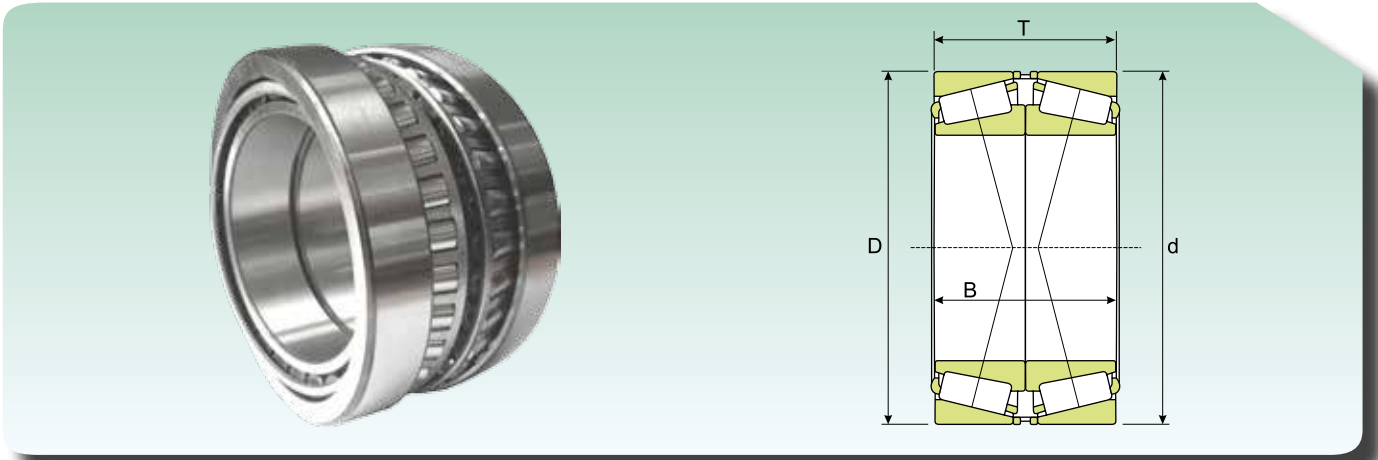

Dimensiones (mm) Dimension (mm)			Coeficiente de carga (KN) Load rating (KN)		Velocidad límite (rpm) Speed limit (Rpm)		Peso (Kg) Weight (Kg)	Sigla Designation
d (mm)	D (mm)	T (mm)	Dinámico Dynamic C	Estático Static C ₀	Lubrificación Lubrication			
					Grasa Grease	Aceite Oil		
100	150	64	286,16	548,8	3600	3800	3,95	32020 X/DF
	180	74	409,64	627,2	3240	3420	7,60	30220 J/DF
	180	98	528,22	862,4	3240	3420	10,0	32220 J/DF
	215	103	679,14	960,4	2880	3040	16,5	30320J/DFC400
	215	113	631,12	911,4	2700	2850	18,0	31320 XJ/DF
105	160	70	340,06	656,6	3420	3610	5,00	32021 X/DF
110	170	76	393,96	764,4	3240	3420	6,30	32022 X/DF
	180	112	614,46	1225	3060	3230	11,5	33122/DF
	200	82	512,54	784	2880	3040	10,5	30222 J/DF
	200	112	668,36	1117,2	2880	3040	14,5	32222 J/DF
	240	126	765,38	1136,8	2520	2660	26,0	31322 XJ/DF
120	180	76	409,64	813,4	3060	3230	6,75	32024 X/DF
	180	96	485,1	1058,4	3060	3230	8,65	33024/DFC250
	215	87	571,34	896,7	2700	2850	13,0	30224 J/DF
	215	123	776,16	1372	2700	2850	18,5	32224 J/DF
	260	119	948,64	1372	2340	2470	29,5	30324 J/DFC600
	260	136	916,3	1372	2160	2280	38,5	31324 XJ/DF
130	180	64	334,18	720,3	3240	3420	4,95	32926/DF
	200	90	528,22	1058,4	2700	2850	10,0	30226 X/DF
	230	87,5	614,46	960,4	2520	2660	14,5	30226 J/DF
	230	135,5	932,96	1626,8	2520	2660	23,0	32226 J/DF
	280	144	1029	1528,8	2160	2280	40,0	31326 XJ/DF
140	210	90	549,78	1136,8	2520	2660	11,0	32028 X/DF
	250	91,5	706,58	1117,2	2340	2470	18,0	30228 J/DFC100
	250	143,5	1078	1960	2340	2470	29,5	32228 J/DF
	300	154	1166,2	1764	1980	2090	52,5	31328 XJ/DF
150	225	96	631,12	1293,6	2340	2470	13,5	32030 X/DF
	270	154	1225	2234,4	2160	2280	37,0	32230 J/DF
	320	164	1313,2	1999,2	1800	1900	58,5	31330 XJ/DF
160	240	102	722,26	1528,8	2160	2280	16,0	32032 X/DF
	290	104	894,74	1430,8	1980	2090	27,5	30232 J/DF
	290	168	1479,8	2744	1980	2090	48,0	32232 J/DF
170	230	76	474,32	1136,8	2520	2660	9,20	32934/DFC225
	260	114	862,4	1793,4	1980	2090	22,0	32034 X/DF
	310	182	1685,6	3185	1800	1900	59,0	32234 J/DF
180	250	90	592,9	1430,8	2340	2470	14,0	32936/DF
	280	128	1078	2273,6	1800	1900	29,5	32036 X/DF
	320	114	989,8	1597,4	1800	1900	42,0	30236 J/DF
	320	182	1685,6	3185	1710	1805	61,0	32236 J/DF
190	260	90	603,68	1499,4	2160	2280	14,5	32938/DF
	290	128	1097,6	2352	1800	1900	30,5	32038 X/DF
	340	120	1205,4	1960	1620	1710	50,0	30238 J/DFC700

RODAMIENTOS DE UNA HILERA DE RODILLOS CÓNICOS, APAREADOS CARA A CARA TAPERED ROLLER BEARINGS, SINGLE ROW, FACE-TO-FACE

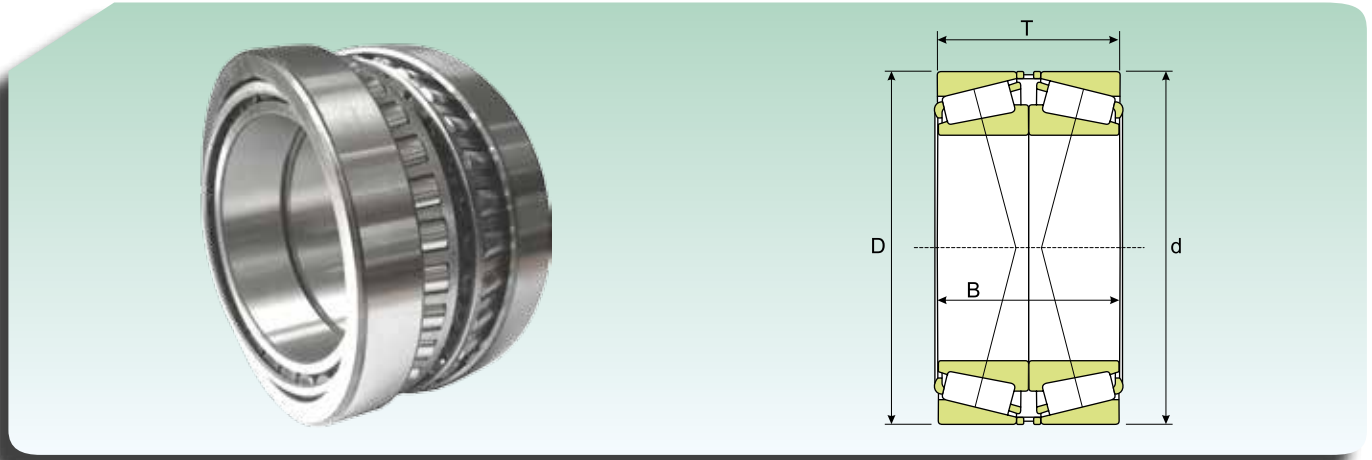

Dimensiones (mm) Dimension (mm)			Coeficiente de carga (KN) Load rating (KN)		Velocidad límite (rpm) Speed limit (Rpm)		Peso (Kg) Weight (Kg)	Sigla Designation
d (mm)	D (mm)	T (mm)	Dinámico Dynamic C	Estático Static C ₀	Lubrificación Lubrication			
					Grasa Grease	Aceite Oil		
200	310	140	1254,4	2695	1710	1805	39,0	32040 X/DF
	360	128	1313,2	2195,2	1530	1615	52,0	30240 J/DFC570
	360	208	2048,2	3920	1530	1615	88,0	32240 J/DF
	300	102	825,16	1960	1800	1900	21,0	32944/DFC300
	340	152	1509,2	3283	1530	1615	51,0	32044 X/DF
240	360	152	1538,6	3479	1440	1520	54,5	32048 X/DF
260	400	174	1940,4	4312	1260	1330	79,5	32052 X/DF
280	420	174	2009	4655	1170	1235	84,5	32056 X/DF
300	420	152	1754,2	4410	1260	1330	65,5	32960/DF
320	480	200	2587,2	6076	990	1045	125	32064 X/DF



Rodamientos de rodillos a rótula

Self-aligning roller bearings

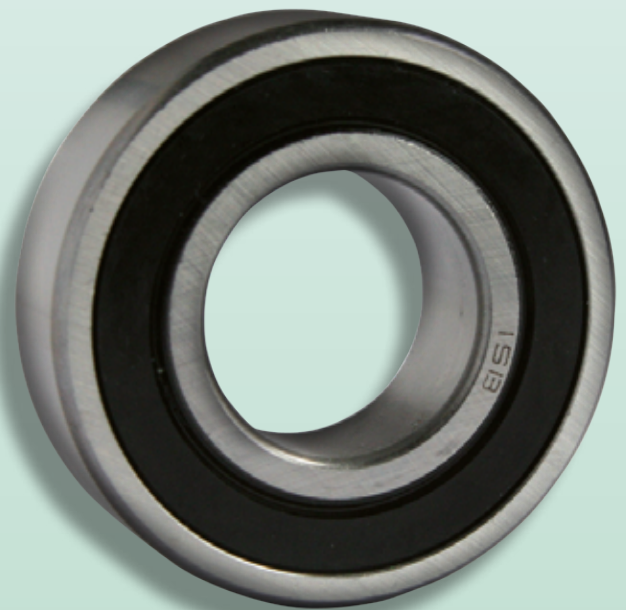

RODAMIENTOS DE RODILLOS A RÓTULA

Los rodamientos ISB® de rodillos a rótula tienen dos hileras de rodillos que giran en un único camino de rodadura de forma esférica presente en el aro exterior (**Fig. 1**). Los correspondientes dos caminos de rodadura del aro interior están inclinados respecto al eje del rodamiento. Son autoalineables y por lo tanto insensibles a las desalineaciones de modesta magnitud del eje respecto al alojamiento o a la inflexión del mismo. Soportan cargas radiales y axiales en ambas direcciones.

SPHERICAL ROLLER BEARINGS

ISB® spherical roller bearings have two rows of rollers that roll in one spherical raceway in the outer ring (**Fig. 1**). The two corresponding raceways of the inner ring are set at an angle compared to the bearing's axis. They are self-aligning and insensitive to slight misalignments of the shaft compared to the housing and to shaft deflections. They withstand radial and axial loads in both directions.

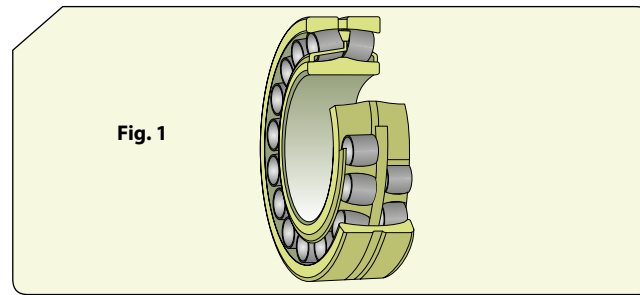

RODAMIENTOS ESTÁNDARES

Se denominan rodamientos autoalineables:

- Rodamientos abiertos: según el tamaño o la serie se producen con diversos diseños, disponibles con agujero cónico o cilíndrico. El agujero cónico tiene una conicidad de 1:30 (serie 240,241,248 e 249, designación en el sufijo K30) o de 1:12 con K como sufijo en la designación. Una ranura anular y tres agujeros de lubricación en el aro exterior facilitan la lubricación del rodamiento (**Fig.2**).

STANDARD BEARINGS

The spherical rollers bearings are:

- Open bearings: based on the size and series, they are manufactured in various versions, available with tapered or cylindrical bore. The tapered bore has a taper of either 1:30 (series 240,241,248 and 249, designation suffix K30) or of 1:12 with designation suffix K. The circumferential groove and three lubrication holes in the outer ring facilitate bearing lubrication (**Fig. 2**).

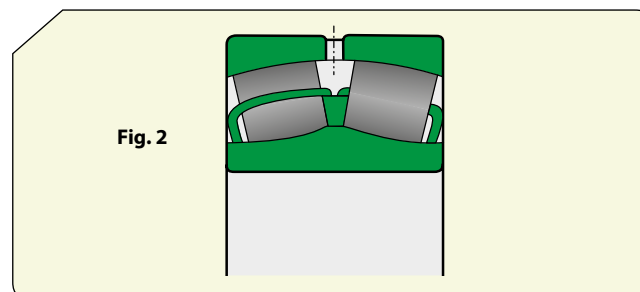

- Rodamientos obturados: Las obturaciones están reforzadas con chapa de acero y son de caucho nitrilo (NBR), lubricados con grasa para altísimas presiones, no deben ser llevados a temperaturas superiores a los 80°C y no se deben lavar (**Fig. 3**).

- Sealed bearings: The seals are reinforced with steel and are made of Nitrile-Butadiene-Rubber (NBR), they are lubricated with grease for very high pressures and must not be heated above 80°C or washed (**Fig. 3**).

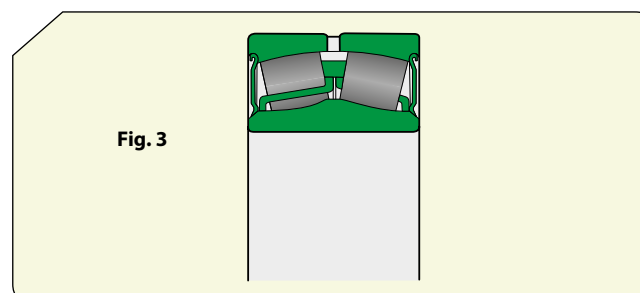

- Rodamientos para aplicaciones vibratorias: las aplicaciones vibratorias, como las cribas, someten los rodamientos a mayores tensiones respecto a los rodamientos estándares.

- Bearings for vibratory applications: Vibratory applications, such as vibrating screens or energisers, subject the bearings to greater strain than standard bearings.

RODAMIENTOS SOBRE MANGUITOS

Los rodamientos **ISB**[®] de rodillos a rótula con un agujero cónico se pueden montar sobre ejes lisos o escalonados usando:

- Manguito de fijación (**Fig. 4a**).
- Manguito de desmontaje (**Fig. 4b**).

Los manguitos facilitan el montaje y desmontaje del rodamiento, simplificando el diseño de su disposición.

BEARINGS ON SLEEVES

ISB[®] spherical roller bearings with tapered bore can be fitted on smooth or stepped shafts

- Adapter sleeve (**Fig. 4a**);
- Withdrawal sleeve (**Fig 4b**).

These sleeves facilitate assembly and disassembly and simplify the arrangement of the bearings.

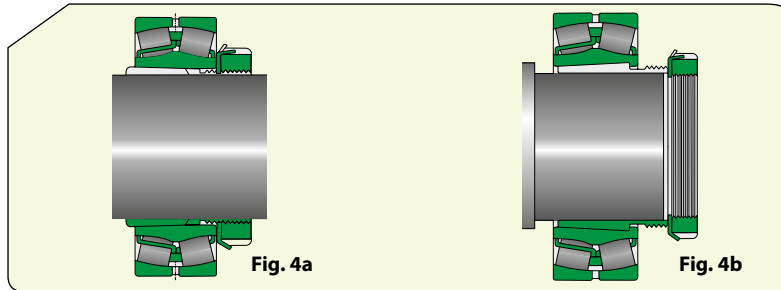

DIMENSIONES

Las dimensiones cumplen con la norma ISO 15:1998. Las dimensiones de los manguitos de fijación o de desmontaje cumplen con la norma ISO 2982-1:1995.

TOLERANCIAS

Los rodamientos **ISB**[®] de rodillos a rótula con agujero cónico o cilíndrico se fabrican según la tolerancia normal.

JUEGO INTERNO

Los rodamientos **ISB**[®] de rodillos a rótula se fabrican con juego interior radial normal. Muchos de ellos están disponibles también con juego interior sobredimensionado C3 y aún mayor, C4. Algunos de suministran con juego interior C2, menor que el normal. Verificar siempre la disponibilidad de los juegos interiores diferentes al normal (incluidos C5, mayor que C4) antes de efectuar el pedido.

DESALINEACIÓN

Las desalineaciones angulares no influyen sobre las prestaciones en este tipo de rodamiento, en virtud de su forma constructiva.

CAPACIDAD DE CARGA AXIAL

Soportan fuertes cargas axiales gracias a su especial forma constructiva interior.

DESIGNACIONES SUPLEMENTARIAS

- C2** Juego radial interior inferior al normal
- C3** Juego radial interior superior al normal
- C4** Juego radial interior mayor que C3
- C5** Juego interior radial mayor que C4
- 2RS** Obturación de goma acrílonitrilo-butadieno (NBR), reforzada con chapa de acero en ambos lados del rodamiento. Ranura anular y tres agujeros de lubricación en el aro exterior
- K** Agujero cónico, conicidad 1:12
- K30** Agujero cónico, conicidad 1:30

DIMENSIONS

The dimensions comply with standard ISO 15:1998. The dimensions of the adapter or withdrawal sleeves comply with standard ISO 2982-1:1995.

TOLERANCES

ISB[®] spherical roller bearings with tapered or cylindrical bore are manufactured with Normal tolerance.

INTERNAL CLEARANCE

ISB[®] spherical roller bearings are manufactured with Normal internal radial clearance. They are mostly available also with greater internal clearance C3 and much greater clearance C4. Some are supplied with internal clearance C2 that is smaller than Normal. Always check availability of internal clearances different to standard before placing orders (including C5, greater than C4).

MISALIGNMENT

Angular misalignments do not affect the performance of this type of bearing thanks to its constructional design.

AXIAL LOAD CARRYING CAPACITY

These bearings withstand strong axial loads thanks to the special internal constructional design.

SUPPLEMENTARY DESIGNATIONS

- C2** Internal radial clearance smaller than Normal.
- C3** Internal radial clearance greater than Normal.
- C4** Internal radial clearance greater than C3.
- C5** Internal radial clearance greater than C4.
- 2RS** Nitrile-Butadiene-Rubber contact seal (NBR), with sheet steel reinforcement, on both sides of the bearing. Circumferential groove and three lubrication holes in the outer ring.
- K** Tapered bore, taper 1:12.
- K30** Tapered bore, taper 1:30;

- P5** Mayor precisión dimensional y de rotación, de conformidad con la clase de tolerancia 5 de la norma ISO
- P6** Mayor precisión dimensional y de rotación, de conformidad con la clase de tolerancia 6 de la norma ISO
- P62** P6 + C2
- VA** Rodamientos para aplicaciones vibratorias
- W33** Ranura anular y tres agujeros de lubricación en el aro exterior

- P5** *Greater dimensional and rotation precision, compliant with tolerance class 5 of ISO standard*
- P6** *Greater dimensional and rotation precision, compliant with tolerance class 6 of ISO standard*
- P62** *P6 + C2*
- VA** *Bearings for vibratory applications*
- W33** *Circumferential groove and three lubrication holes in outer ring*

RODAMIENTOS DE RODILLOS A RÓTULA
SELF-ALIGNING ROLLER BEARINGS

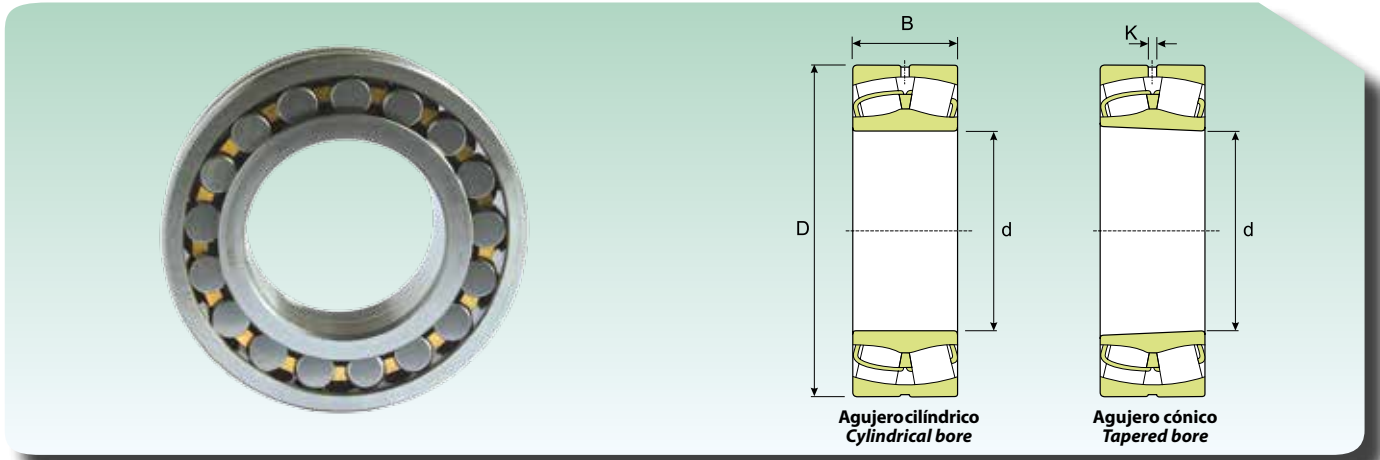

Dimensiones (mm) Dimension (mm)				Coeficiente de carga (KN) Load rating (KN)		Velocidad límite (rpm) Speed limit (Rpm)		Peso (Kg) Weight (Kg)	Sigla Designation	
d (mm)	D (mm)	B (mm)	K (mm)	Dinámico Dynamic C	Estático Static C ₀	Lubricación Lubrication			Agujero cilíndrico Cylindrical bore	Agujero Cónico Tapered bore
						Grasa Grease	Aceite Oil			
20	52	18	2	48	43	13005	15300	0.28	22205/20	-
	62	17	-	41	41	9180	10800	0.28	21305	-
30	62	20	2	63	59	10710	12600	0.29	22206	22206 K
	72	19	-	54	60	7650	9000	0.41	21306	21306 K
35	72	23	2	85	83	9180	10800	0.45	22207	22207 K
	80	21	-	64	71	7267.5	8550	0.55	21307	21307 K
40	80	23	3	95	88	8415	9900	0.53	22208	22208 K
	90	23	3	102	106	7267.5	8550	0.75	21308	21308 K
	90	33	3	147	137	6120	7200	1.05	22308	22308 K
45	85	23	3	100	96	7650	9000	0.58	22209	22209 K
	100	25	3	123	124	6502.5	7650	0.99	21309	21309 K
	100	36	3	179	179	5355	6300	1.4	22309	22309 K
50	90	23	3	102	106	7267.5	8550	0.63	22210	22210 K
	110	27	3	153	163	5737.5	6750	1.35	21310	21310 K
	110	40	3	216	220	4819.5	5670	1.9	22310	22310 K
55	100	25	3	123	124	6502.5	7650	0.84	22211	22211 K
	120	29	3	153	163	5737.5	6750	1.7	21311	21311 K
	120	43	3	265	274	4284	5040	2.45	22311	22311 K
60	110	28	3	153	163	5737.5	6750	1.15	22212	22212 K
	130	31	3	208	235	4819.5	5670	2.1	21312	21312 K
	130	46	4.5	304	328	4054.5	4770	3.1	22312	22312 K
65	100	35	2	129	170	4819.5	5670	0.95	24013	24013 K30
	120	31	3	189	212	5355	6300	1.55	22213	22213 K
	140	33	3	231	265	4590	5400	2.55	21313	21313 K
	140	48	4.5	333	353	3825	4500	3.75	22313	22313 K
70	125	31	3	204	223	5125.5	6030	1.55	22214	22214 K
	150	35	3	279	319	4284	5040	3.1	21314	21314 K
	150	51	4.5	392	421	3442.5	4050	4.55	22314	22314 K
75	115	40	3	170	227	4054.5	4770	1.55	24015	24015 K30
	130	31	3	208	235	4819.5	5670	1.7	22215	22215 K
	160	37	3	279	319	4284	5040	3.75	21315	21315 K
	160	55	4.5	431	466	3289.5	3870	5.55	22315	22315 K
80	140	33	3	231	265	4590	5400	2.1	22216	22216 K
	170	39	3	319	368	4054.5	4770	4.45	21316	21316 K
	170	58	4.5	480	529	3060	3600	6.6	22316	22316 K
85	150	36	3	279	319	4284	5040	2.65	22217	22217 K
	180	41	3	319	368	4054.5	4770	5.2	21317	21317 K
	180	60	4.5	539	608	2907	3420	7.65	22317	22317 K

Bajo demanda disponible con ranura anular y tres agujeros de lubricación en el aro exterior.
Under request available with circumferential groove and three lubrication noles in auter ring.

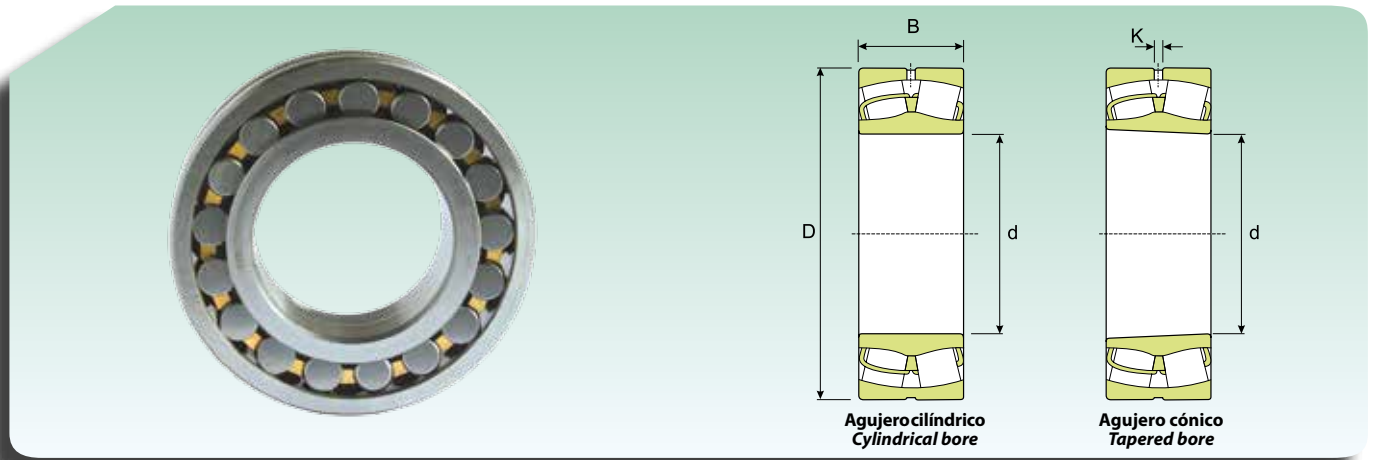
**RODAMIENTOS DE RODILLOS A RÓTULA
SELF-ALIGNING ROLLER BEARINGS**

Dimensiones (mm) Dimension (mm)				Coeficiente de carga (KN) Load rating (KN)		Velocidad límite (rpm) Speed limit (Rpm)		Peso (Kg) Weight (Kg)	Sigla Designation	
d (mm)	D (mm)	B (mm)	K (mm)	Dinámico Dynamic C	Estático Static C ₀	Lubricación Lubrication			Agujero cilíndrico Cylindrical bore	Agujero Cónico Tapered bore
						Grasa Grease	Aceite Oil			
90	160	40	3	319	368	4054.5	4770	3.4	22218	22218 K
	160	52.4	3	348	431	2907	3420	4.65	23218	23218 K
	190	43	4.5	372	441	3672	4320	6.1	21318	21318 K
	190	64	6	598	681	2754	3240	9.05	22318	22318 K
95	170	43	4.5	372	441	3672	4320	4.15	22219	22219 K
	200	45	4.5	417	480	3442.5	4050	7.05	21319	21319 K
	200	67	6	657	750	2601	3060	10.5	22319	22319 K
100	150	50	3	279	407	3060	3600	3.15	24020	24020 K30
	165	52	3	358	480	3060	3600	4.55	23120	23120 K
	165	65	2	446	627	2448	2880	5.65	24120	24120 K30
	180	46	4.5	417	480	3442.5	4050	4.9	22220	22220 K
	180	60.3	4.5	466	588	2601	3060	6.85	23220	23220 K
	215	47	4.5	417	480	3442.5	4050	8.6	21320	21320 K
	215	73	6	799	931	2295	2700	13.5	22320	22320 K
110	170	45	3	304	431	3289.5	3870	3.8	23022	23022 K
	170	60	3	407	608	2754	3240	5	24022	24022 K30
	180	56	4.5	421	573	2754	3240	5.75	23122	23122 K
	180	69	3	510	735	2295	2700	7.1	24122	24122 K30
	200	53	4.5	549	627	3060	3600	7	22222	22222 K
	200	69.8	4.5	588	750	2448	2880	9.85	23222	23222 K
	240	80	7.5	931	1098	2142	2520	18.4	22322	22322 K
120	180	46	3	348	500	3060	3600	4.2	23024	23024 K
	180	60	3	421	657	2601	3060	5.45	24024	24024 K30
	200	62	4.5	500	681	2601	3060	8	23124	23124 K
	200	80	3	642	931	1989	2340	10.3	24124	24124 K30
	215	58	6	617	750	2907	3420	8.7	22224	22224 K
	215	76	4.5	681	911	2142	2520	12	23224	23224 K
	260	86	7.5	946	1098	1989	2340	23	22324	22324 K
	130	200	52	4.5	421	598	2754	3240	6	23026
200		69	3	529	799	2295	2700	8.05	24026	24026 K30
210		64	4.5	549	764	2448	2880	8.8	23126	23126 K
210		80	3	666	980	1836	2160	11	24126	24126 K30
230		64	6	720	911	2754	3240	11	22226	22226 K
230		80	4.5	764	1039	1989	2340	14.5	23226	23226 K
280		93	9	1098	1294	1836	2160	29	22326	22326 K
140		210	53	4.5	456	666	2601	3060	6.55	23028
	210	69	3	559	882	2142	2520	8.55	24028	24028 K30
	225	68	4.5	617	882	2142	2520	10.5	23128	23128 K
	225	85	4.5	750	1137	1836	2160	13.5	24128	24128 K30
	250	68	6	696	882	2448	2880	14	22228	22228 K
	250	88	6	897	1225	1836	2160	19	23228	23228 K
	300	102	9	1264	1529	1683	1980	36.5	22328	22328 K

Bajo demanda disponible con ranura anular y tres agujeros de lubricación en el aro exterior.
Under request available with circumferential groove and three lubrication noles in auter ring.

RODAMIENTOS DE RODILLOS A RÓTULA
SELF-ALIGNING ROLLER BEARINGS

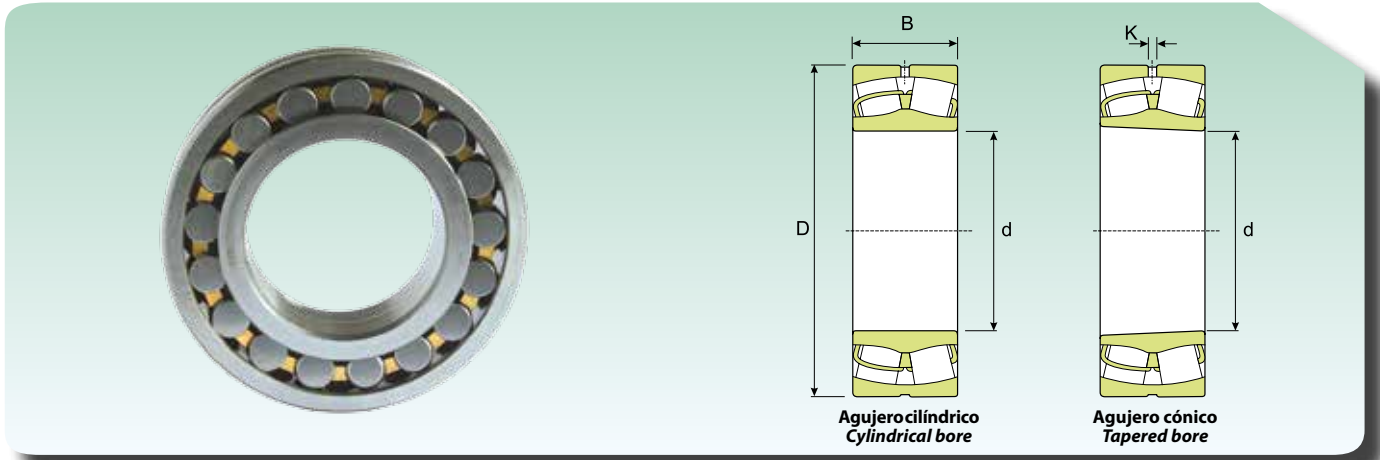

Dimensiones (mm) Dimension (mm)				Coeficiente de carga (KN) Load rating (KN)		Velocidad límite (rpm) Speed limit (Rpm)		Peso (Kg) Weight (Kg)	Sigla Designation	
d (mm)	D (mm)	B (mm)	K (mm)	Dinámico Dynamic C	Estático Static C ₀	Lubricación Lubrication			Agujero cilíndrico Cylindrical bore	Agujero Cónico Tapered bore
						Grasa Grease	Aceite Oil			
150	225	56	4.5	500	735	2448	2880	7.95	23030	23030 K
	225	75	3	642	1019	1989	2340	10.5	24030	24030 K30
	250	80	6	813	1176	1989	2340	16	23130	23130 K
	250	100	4.5	1000	1499	1683	1980	20	24130	24130 K30
	270	73	7.5	833	1058	2295	2700	18	22230	22230 K
	270	96	6	1058	1431	1683	1980	24.5	23230	23230 K
	320	108	9	1431	1725	1530	1800	43.5	22330	22330 K
160	240	60	6	573	862	2295	2700	9.7	23032	23032 K
	240	80	4.5	735	1176	1836	2160	13	24032	24032 K30
	270	86	7.5	960	1343	1836	2160	20.5	23132	23132 K
	270	109	4.5	1156	1725	1453.5	1710	25	24132	24132 K30
	290	80	7.5	980	1264	2142	2520	22.5	22232	22232 K
	290	104	7.5	1196	1627	1683	1980	31	23232	23232 K
	340	114	9	1568	1921	1453.5	1710	52	22332	22332 K
170	260	67	6	696	1039	2142	2520	13	23034	23034 K
	260	90	4.5	911	1431	1836	2160	17.5	24034	24034 K30
	280	88	7.5	1019	1470	1836	2160	22	23134	23134 K
	280	109	4.5	1196	1823	1453.5	1710	27.5	24134	24134 K30
	310	86	9	1098	1431	1989	2340	28.5	22234	22234 K
	310	110	7.5	1372	1891	1530	1800	37.5	23234	23234 K
	360	120	9	1725	2117	1377	1620	61	22334	22334 K
180	250	52	3	422	813	2142	2520	7.9	23936	23936 K
	280	74	7.5	813	1225	1989	2340	17	23036	23036 K
	280	100	4.5	1058	1695	1683	1980	23	24036	24036 K30
	300	96	7.5	1176	1725	1683	1980	28	23136	23136 K
	300	118	6	1372	2117	1300.5	1530	34.5	24136	24136 K30
	320	86	9	1156	1529	1989	2340	29.5	22236	22236 K
	320	112	7.5	1470	2078	1453.5	1710	39.5	23236	23236 K
	380	126	9	1960	2401	1300.5	1530	71.5	22336	22336 K
190	260	52	3	406	784	1989	2340	8.3	23938	23938 K
	290	75	7.5	848	1313	1836	2160	18	23038	23038 K
	290	100	4.5	1098	1764	1530	1800	24.5	24038	24038 K30
	320	104	7.5	1343	2038	1530	1800	35	23138	23138 K
	320	128	6	1568	2450	1224	1440	43	24138	24138 K30
	340	92	9	1245	1666	1836	2160	36.5	22238	22238 K
	340	120	9	1627	2352	1377	1620	48	23238	23238 K
	400	132	6	2078	2597	1224	1440	82.5	22338	22338 K
200	280	60	4.5	535	1019	1836	2160	11.5	23940	23940 K
	310	82	7.5	980	1499	1683	1980	23.3	23040	23040 K
	310	109	6	1264	2078	1453.5	1710	31	24040	24040 K30
	340	112	9	1568	2313	1453.5	1710	43	23140	23140 K
	340	140	6	1764	2744	1147.5	1350	53.5	24140	24140 K30
	360	98	9	1431	1891	1683	1980	43.5	22240	22240 K
	360	128	9	1823	2646	1300.5	1530	58	23240	23240 K
	420	138	12	2274	2842	1147.5	1350	95	22340	22340 K

Bajo demanda disponible con ranura anular y tres agujeros de lubricación en el aro exterior.
Under request available with circumferential groove and three lubrication holes in outer ring.

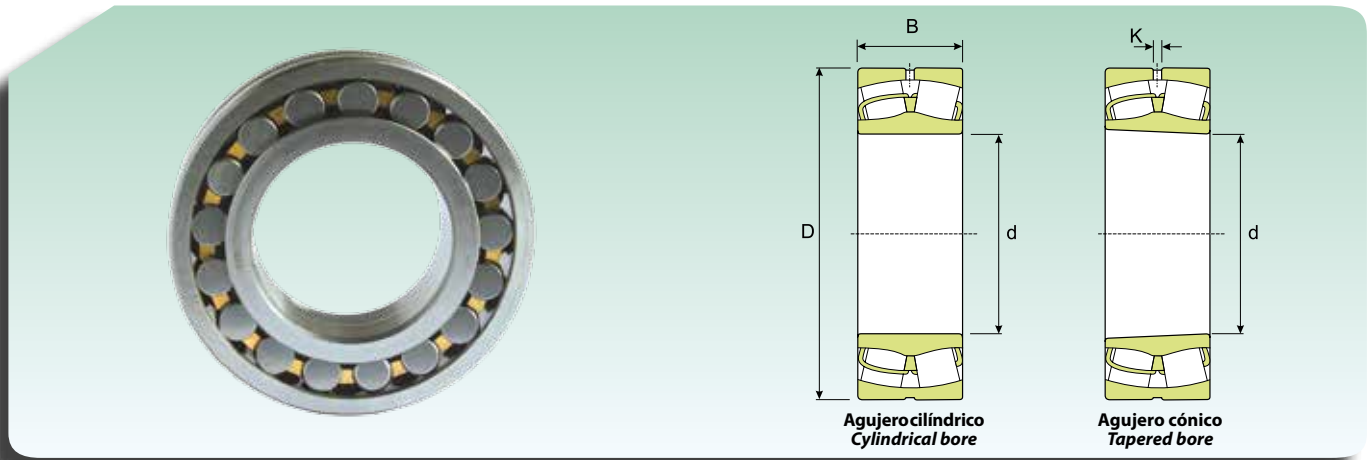
**RODAMIENTOS DE RODILLOS A RÓTULA
SELF-ALIGNING ROLLER BEARINGS**

Dimensiones (mm) Dimension (mm)				Coeficiente de carga (KN) Load rating (KN)		Velocidad límite (rpm) Speed limit (Rpm)		Peso (Kg) Weight (Kg)	Sigla Designation	
d (mm)	D (mm)	B (mm)	K (mm)	Dinámico Dynamic C	Estático Static C ₀	Lubricación Lubrication			Agujero cilíndrico Cylindrical bore	Agujero Cónico Tapered bore
						Grasa Grease	Aceite Oil			
220	300	60	4.5	535	1058	1683	1980	12.5	23944	23944 K
	340	90	7.5	1196	1823	1530	1800	30.5	23044	23044 K
	340	118	6	1529	2548	1300.5	1530	40	24044	24044 K30
	370	120	9	1764	2695	1300.5	1530	53.5	23144	23144 K
	370	150	6	2078	3283	1071	1260	67	24144	24144 K30
	400	108	9	1725	2313	1530	1800	60.5	22244	22244 K
	400	144	9	2313	3381	1147.5	1350	81.5	23244	23244 K
	460	145	12	2646	3381	1071	1260	120	22344	22344 K
240	320	60	4.5	553	1137	1530	1800	13.5	23948	23948 K
	360	92	7.5	1264	2038	1453.5	1710	33.5	23048	23048 K
	360	118	6	1568	2646	1224	1440	43	24048	24048 K30
	400	128	9	2038	3136	1224	1440	66.5	23148	23148 K
	400	160	6	2352	3822	994.5	1170	83	24148	24148 K30
	440	120	9	2156	2940	1377	1620	83	22248	22248 K
	440	160	9	2842	4214	994.5	1170	110	23248	23248 K
	500	155	12	3038	3920	994.5	1170	155	22348	22348 K
260	360	75	4.5	862	1764	1453.5	1710	23.5	23952	23952 K
	400	104	7.5	1568	2499	1300.5	1530	48.5	23052	23052 K
	400	140	6	1999	3381	1071	1260	65.5	24052	24052 K30
	440	144	9	2499	3822	1071	1260	90.5	23152	23152 K
	440	180	6	2940	4704	918	1080	110	24152	24152 K30
	480	130	12	2597	3479	1224	1440	110	22252	22252 K
	480	174	12	3185	4655	918	1080	140	23252	23252 K
	540	165	12	3479	4459	841.5	990	190	22352	22352 K
280	380	75	6	828	1725	1300.5	1530	25	23956	23956 K
	420	106	9	1695	2793	1224	1440	52.5	23056	23056 K
	420	140	6	2117	3724	1071	1260	69.5	24056	24056 K30
	460	146	9	2597	4165	994.5	1170	97	23156	23156 K
	460	180	7.5	3038	4998	841.5	990	120	24156	24156 K30
	500	130	12	2646	3675	1147.5	1350	115	22256	22256 K
	500	176	12	3185	4802	841.5	990	150	23256	23256 K
	580	175	12	3920	5096	841.5	990	235	22356	22356 K
300	380	90	-	620	1560	1150	1350	16.5	23860	23860 K
	420	90	6	1176	2450	1224	1440	39.5	23960	23960 K
	460	118	9	2078	3381	1147.5	1350	71.5	23060	23060 K
	460	160	7.5	2646	4655	918	1080	97	24060	24060 K30
	500	160	9	3136	4998	918	1080	125	23160	23160 K
	500	200	7.5	3675	6174	765	900	160	24160	24160 K30
	540	140	12	3087	4165	1071	1260	145	22260	22260 K
	540	192	12	3822	5733	765	900	190	23260	23260 K
320	440	90	6	1401	2646	1147.5	1350	42	23964	23964 K
	480	121	9	2195	3724	1071	1260	78	23064	23064 K
	480	160	7.5	2793	4998	918	1080	100	24064	24064 K30
	540	176	12	3675	5880	841.5	990	165	23164	23164 K
	540	218	9	4165	6958	688.5	810	210	24164	24164 K30
	580	150	12	3528	4802	994.5	1170	175	22264	22264 K
	580	208	12	4312	6566	726.75	855	240	23264	23264 K

Bajo demanda disponible con ranura anular y tres agujeros de lubricación en el aro exterior.
Under request available with circumferential groove and three lubrication noles in auter ring.

RODAMIENTOS DE RODILLOS A RÓTULA
SELF-ALIGNING ROLLER BEARINGS

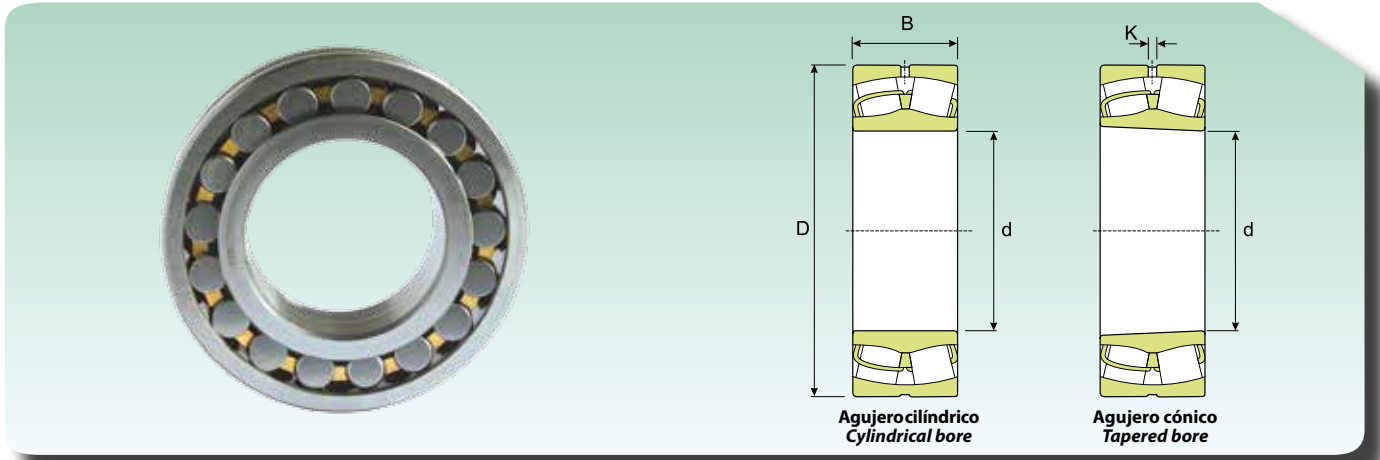

Dimensiones (mm) Dimension (mm)				Coeficiente de carga (KN) Load rating (KN)		Velocidad límite (rpm) Speed limit (Rpm)		Peso (Kg) Weight (Kg)	Sigla Designation	
d (mm)	D (mm)	B (mm)	K (mm)	Dinámico Dynamic C	Estático Static C ₀	Lubricación Lubrication			Agujero cilíndrico Cylindrical bore	Agujero Cónico Tapered bore
						Grasa Grease	Aceite Oil			
340	460	90	6	1431	2744	1071	1260	45.5	23968	23968 K
	520	133	12	2646	4459	994.5	1170	105	23068	23068 K
	520	180	9	3381	6076	841.5	990	140	24068	24068 K30
	580	190	12	4165	6664	765	900	210	23168	23168 K
	580	243	9	5194	8477	650.25	765	280	24168	24168 K30
	620	224	12	4998	7644	612	720	295	23268	23268 K
360	480	90	6	1372	2695	994.5	1170	46	23972	23972 K
	540	134	12	2695	4704	918	1080	110	23072	23072 K
	540	180	9	3479	6419	765	900	145	24072	24072 K30
	600	192	12	4214	6811	765	900	220	23172	23172 K
	600	243	9	5488	9114	612	720	280	24172	24172 K30
	650	170	12	4214	6076	650.25	765	255	22272	22272 K
	650	232	12	5292	8134	573.75	675	335	23272	23272 K
380	520	106	7.5	1921	3724	918	1080	69	23976	23976 K
	560	135	12	2842	4900	918	1080	115	23076	23076 K
	560	180	9	3528	6664	726.75	855	150	24076	24076 K30
	620	194	12	4312	6958	765	900	230	23176	23176 K
	620	243	9	5586	9604	650.25	765	300	24176	24176 K30
	680	240	12	5733	8967	573.75	675	375	23276	23276 K
400	540	106	7.5	1960	3822	918	1080	71	23980	23980 K
	600	148	12	3185	5586	841.5	990	150	23080	23080 K
	600	200	12	4214	7840	688.5	810	205	24080	24080 K30
	650	200	12	4557	7497	726.75	855	265	23180	23180 K
	650	250	12	6076	10388	612	720	340	24180	24180 K30
	720	256	12	6419	10192	512.55	603	450	23280	23280 K
	820	243	12	7350	10192	573.75	675	650	22380	22380 K
420	560	106	9	1999	4067	841.5	990	74.5	23984	23984 K
	620	150	12	3332	5880	841.5	990	155	23084	23084 K
	620	200	12	4312	8134	688.5	810	210	24084	24084 K30
	700	224	12	5488	9114	688.5	810	350	23184	23184 K
	700	280	12	7203	12348	535.5	630	445	24184	24184 K30
	760	272	12	7203	11368	481.95	567	535	23284	23284 K
	440	600	118	9	2401	4802	765	900	99.5	23988
650		157	12	3577	6419	765	900	180	23088	23088 K
650		212	12	4704	8967	650.25	765	245	24088	24088 K30
720		226	12	5880	9800	650.25	765	360	23188	23188 K
720		280	12	7350	12936	535.5	630	460	24188	24188 K30
790		280	12	7644	12250	459	540	590	23288	23288 K
460	580	118	6	1754	4802	841.5	990	75.5	24892	24892 K30
	620	118	9	2450	4900	765	900	105	23992	23992 K
	680	163	12	3822	6811	726.75	855	205	23092	23092 K
	680	218	12	5096	9800	612	720	275	24092	24092 K30
	760	240	12	6272	10584	612	720	440	23192	23192 K
	760	300	12	8134	14308	512.55	603	560	24192	24192 K30
	830	296	12	8330	13426	428.4	504	695	23292	23292 K

Bajo demanda disponible con ranura anular y tres agujeros de lubricación en el aro exterior.
Under request available with circumferential groove and three lubrication noles in auter ring.

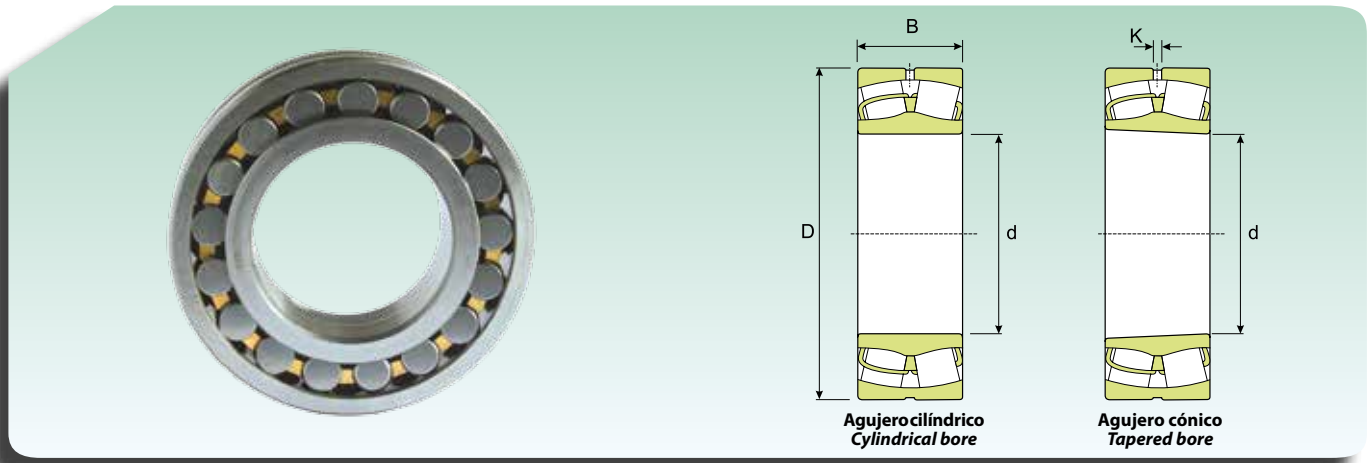
**RODAMIENTOS DE RODILLOS A RÓTULA
SELF-ALIGNING ROLLER BEARINGS**

Dimensiones (mm) Dimension (mm)				Coeficiente de carga (KN) Load rating (KN)		Velocidad límite (rpm) Speed limit (Rpm)		Peso (Kg) Weight (Kg)	Sigla Designation	
d (mm)	D (mm)	B (mm)	K (mm)	Dinámico Dynamic C	Estático Static C ₀	Lubricación Lubrication			Agujero cilíndrico Cylindrical bore	Agujero Cónico Tapered bore
						Grasa Grease	Aceite Oil			
480	600	90	7.5	1411	3675	792	990	61	23896	23896 K
	650	128	7.5	2842	5586	765	900	125	23996	23996 K
	700	165	9	3822	6664	726.75	855	215	23096	23096 K
	700	218	12	5194	10192	573.75	675	285	24096	24096 K30
	790	248	12	6811	11760	573.75	675	485	23196	23196 K
	790	308	12	8820	15288	481.95	567	605	24196	24196 K30
	870	310	12	9114	14700	405.45	477	800	23296	23296 K
500	620	90	7.5	1450	3920	900	720	62	238/500	238/500 K
	670	128	7.5	2842	5880	726.75	855	130	239/500	239/500 K
	720	167	12	4067	7644	688.5	810	225	230/500	230/500 K
	720	218	12	5390	10780	535.5	630	295	240/500	240/500 K30
	830	264	12	7497	12642	535.5	630	580	231/500	231/500 K
	830	325	12	9604	16660	459	540	700	241/500	241/500 K30
	920	336	12	10388	16954	382.5	450	985	232/500	232/500 K
	530	650	118	7.5	1803	5194	726.75	855	86	248/530
710		136	12	3136	6566	688.5	810	155	239/530	239/530 K
780		185	12	4998	9114	612	720	310	230/530	230/530 K
780		250	12	6566	12936	512.55	603	410	240/530	240/530 K30
870		272	12	7987	13720	512.55	603	645	231/530	231/530 K
870		335	12	10388	18620	428.4	504	830	241/530	241/530 K30
980		355	12	10878	19992	367.2	432	1200	232/530	232/530 K
560	750	140	12	3381	7056	650.25	765	175	239/560	239/560 K
	820	195	12	5488	9996	573.75	675	355	230/560	230/560 K
	820	258	12	7203	14308	481.95	567	465	240/560	240/560 K30
	920	280	12	8967	15680	481.95	567	740	231/560	231/560 K
	920	355	12	11760	21168	382.5	450	985	241/560	241/560 K30
	1030	365	12	11270	21560	328.95	387	1350	232/560	232/560 K
600	800	150	12	3822	8134	573.75	675	220	239/600	239/600 K
	870	200	12	5880	11172	535.5	630	405	230/600	230/600 K
	870	272	12	7987	16660	428.4	504	520	240/600	240/600 K30
	980	300	12	9996	17640	428.4	504	895	231/600	231/600 K
	980	375	12	11270	23128	367.2	432	1200	241/600	241/600 K30
	1090	388	12	12838	24990	306	360	1600	232/600	232/600 K
630	780	112	9	2146	5978	573.75	675	120	238/630	238/630 K
	850	165	12	4557	9604	535.5	630	280	239/630	239/630 K
	920	212	12	6566	12250	512.55	603	485	230/630	230/630 K
	920	290	12	8624	17640	405.45	477	645	240/630	240/630 K30
	1030	315	12	10290	20384	405.45	477	1050	231/630	231/630 K
	1030	400	12	12446	26460	344.25	405	1400	241/630	241/630 K30
670	820	112	9	2205	6272	535.5	630	130	238/670	238/670 K
	820	150	9	3048	9310	535.5	630	172	248/670	-
	900	170	12	4900	10584	512.55	603	315	239/670	239/670 K
	980	230	12	7497	14308	459	540	600	230/670	230/670 K
	980	308	12	9800	19992	382.5	450	790	240/670	240/670 K30
	1090	336	12	10682	21952	382.5	450	1250	231/670	231/670 K

Bajo demanda disponible con ranura anular y tres agujeros de lubricación en el aro exterior.
Under request available with circumferential groove and three lubrication noles in auter ring.

RODAMIENTOS DE RODILLOS A RÓTULA
SELF-ALIGNING ROLLER BEARINGS

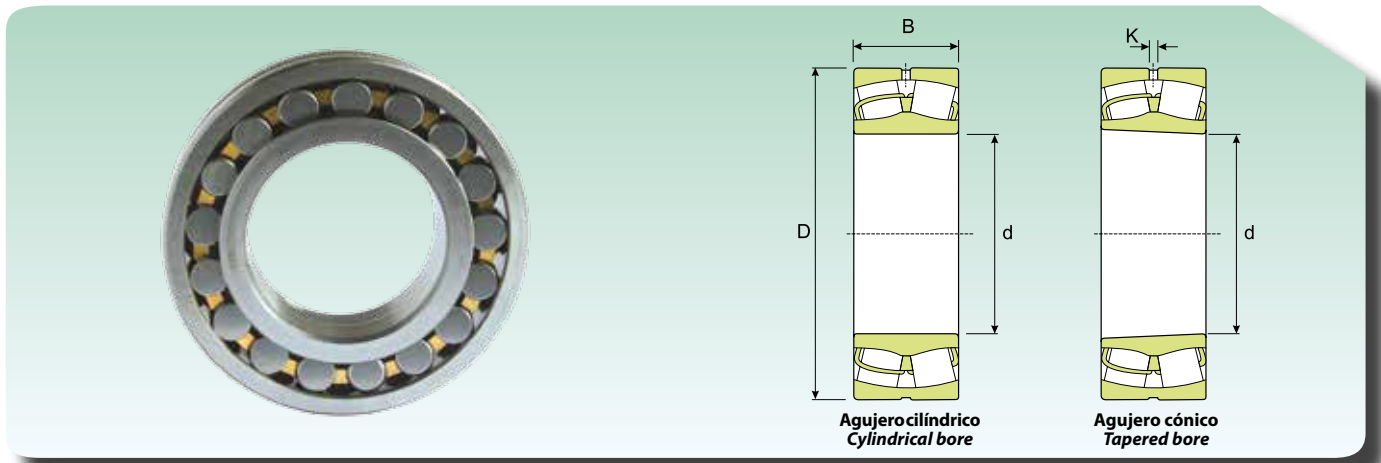

Dimensiones (mm) Dimension (mm)				Coeficiente de carga (kN) Load rating (kN)		Velocidad límite (rpm) Speed limit (Rpm)		Peso (Kg) Weight (Kg)	Sigla Designation	
d (mm)	D (mm)	B (mm)	K (mm)	Dinámico Dynamic C	Estático Static C ₀	Lubricación Lubrication			Agujero cilíndrico Cylindrical bore	Agujero Cónico Tapered bore
						Grasa Grease	Aceite Oil			
670	1090	412	12	13524	28420	306	360	1600	241/670	241/670 K30
	1220	438	12	15092	29890	275.4	324	2270	232/670	232/670 K
710	870	118	12	2528	7350	512.55	603	153	238/710	-
	950	180	12	5488	11760	459	540	365	239/710	239/710 K
	950	243	12	6664	15288	382.5	450	495	249/710	249/710 K30
	1030	236	12	8134	15974	428.4	504	670	230/710	230/710 K
	1030	315	12	10388	22344	344.25	405	895	240/710	240/710 K30
	1150	345	12	11956	25480	344.25	405	1450	231/710	231/710 K
	1150	438	12	14896	31850	290.7	342	1900	241/710	241/710 K30
	1280	450	12	17248	33810	244.8	288	2610	232/710	232/710 K
750	920	128	12	2871	8330	459	540	180	238/750	238/750 K
	1000	185	12	5880	12936	428.4	504	420	239/750	239/750 K
	1000	250	12	7497	17640	367.2	432	560	249/750	249/750 K30
	1090	250	12	9457	18228	405.45	477	795	230/750	230/750 K
	1090	335	12	11564	24500	328.95	387	1065	240/750	240/750 K30
	1220	365	12	13524	28420	328.95	387	1700	231/750	231/750 K
	1220	475	12	16954	36750	275.4	324	2100	241/750	241/750 K30
	1360	475	12	18326	35770	229.5	270	3050	232/750	232/750 K
800	980	180	12	4057	12642	428.4	504	300	248/800	248/800 K30
	1060	195	12	6272	14014	405.45	477	470	239/800	239/800 K
	1060	258	12	7840	18914	328.95	387	640	249/800	249/800 K30
	1150	258	12	9800	19600	367.2	432	895	230/800	230/800 K
	1150	345	12	12642	27930	306	360	1200	240/800	240/800 K30
	1280	375	12	14504	30870	306	360	1920	231/800	231/800 K
	1280	475	12	18032	39690	244.8	288	2300	241/800	241/800 K30
	850	1030	136	12	3273	9800	405.45	477	240	238/850
1120		200	12	6811	15288	367.2	432	560	239/850	239/850 K
1120		272	12	9114	22344	306	360	740	249/850	249/850 K30
1220		272	12	9183	21168	344.25	405	1050	230/850	230/850 K
1220		365	12	12446	30870	275.4	324	1410	240/850	240/850 K30
1360		400	12	15778	33810	275.4	324	2200	231/850	231/850 K
1360		500	12	19796	44100	229.5	270	2710	241/850	241/850 K30
900		1090	190	12	4567	14994	367.2	432	370	248/900
	1180	206	12	7350	16660	344.25	405	605	239/900	239/900 K
	1280	280	12	9898	22736	306	360	1200	230/900	230/900 K
	1280	375	12	13328	33810	260.1	306	1570	240/900	240/900 K30
	1420	515	12	20972	48020	214.2	252	3350	241/900	241/900 K30
950	1250	224	12	7105	19208	328.95	387	755	239/950	239/950 K
	1250	300	12	9016	25480	260.1	306	1015	249/950	249/950 K30
	1360	300	12	11760	27930	290.7	342	1450	230/950	230/950 K
	1360	412	12	14504	38220	229.5	270	1990	240/950	240/950 K30
	1500	545	12	23422	53900	198.9	234	3535	241/950	241/950 K30

Bajo demanda disponible con ranura anular y tres agujeros de lubricación en el aro exterior.
Under request available with circumferential groove and three lubrication holes in outer ring.

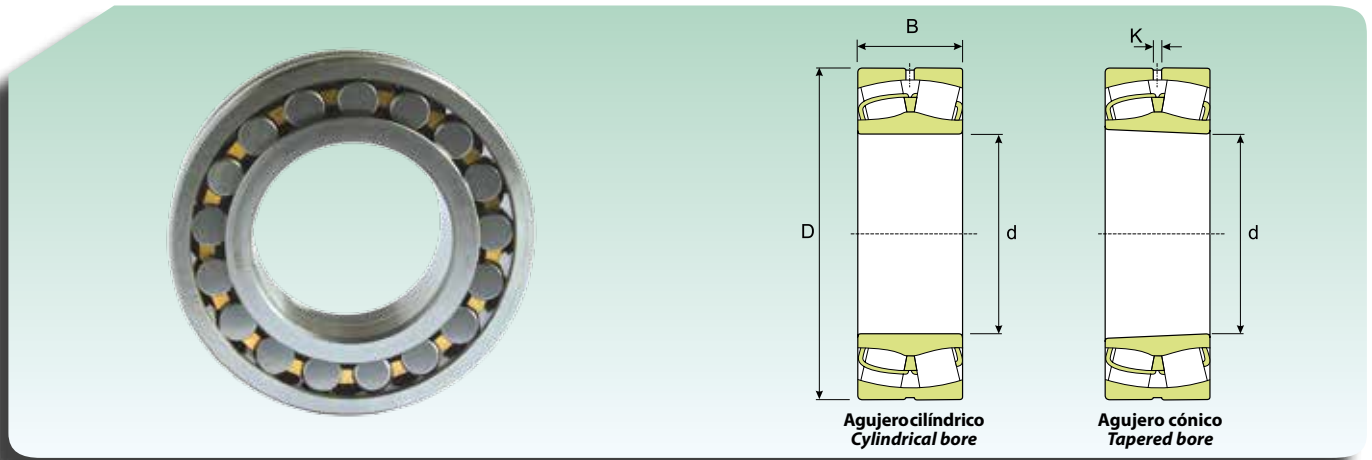
**RODAMIENTOS DE RODILLOS A RÓTULA
SELF-ALIGNING ROLLER BEARINGS**

Dimensiones (mm) Dimension (mm)				Coeficiente de carga (KN) Load rating (KN)		Velocidad límite (rpm) Speed limit (Rpm)		Peso (Kg) Weight (Kg)	Sigla Designation	
d (mm)	D (mm)	B (mm)	K (mm)	Dinámico Dynamic C	Estático Static C ₀	Lubrificación Lubrication			Agujero cilíndrico Cylindrical bore	Agujero Cónico Tapered bore
						Grasa Grease	Aceite Oil			
1000	1220	165	12	4567	14014	306	360	410	238/1000	238/1000 K
	1320	315	12	10192	28420	244.8	288	1200	249/1000	249/1000 K30
	1420	308	12	12446	29890	275.4	324	1600	230/1000	230/1000 K
	1420	412	12	15092	39690	214.2	252	2140	240/1000	240/1000 K30
	1580	462	12	20972	47040	214.2	252	3500	231/1000	231/1000 K
	1580	580	12	26166	60760	183.6	216	4300	241/1000	241/1000 K30
1060	1280	165	12	4674.6	14700	273.6	342	435	238/1060	238/1060 K
	1280	218	12	5978	19600	273.6	342	570	248/1060	248/1060 K
	1400	250	12	9359	25480	259.2	324	1100	239/1060	239/1060 K
	1400	335	12	11270	31850	201.6	252	1400	249/1060	249/1060 K
	1500	325	12	13524	33320	230.4	288	2250	230/1060	230/1060 K
	1500	438	12	16954	44590	187.2	234	2515	240/1060	240/1060 K
1120	1360	243	12	7105	23520	244.8	306	735	248/1120	248/1120 K
	1460	335	12	11466	33810	187.2	234	1500	249/1120	249/1120 K
	1580	462	12	18326	4900	172.8	216	2925	240/1120	240/1120 K
1180	1420	180	12	5752.6	18228	230.4	288	575	238/1180	238/1180 K
	1420	243	12	7555.8	26460	230.4	288	770	248/1180	248/1180 K
	1540	272	12	10878	30380	216	270	1400	239/1180	239/1180 K
	1540	355	12	13328	39690	172.8	216	1800	249/1180	249/1180 K
1250	1750	375	12	17542	44100	93.6	117	2840	230/1250	230/1250 K
1320	1600	280	12	9584.4	32830	187.2	234	1160	248/1320	248/1320 K
	1720	400	12	15778	48020	144	180	2500	249/1320	249/1320 K
1500	1820	315	12	12446	44100	144	180	1710	248/1500	248/1500 K
1800	2180	375	12	17248	61740	93.6	117	2900	248/1800	248/1800 K

RODAMIENTOS DE RODILLOS A RÓTULA BLINDADOS
SEALED SELF-ALIGNING ROLLER BEARINGS

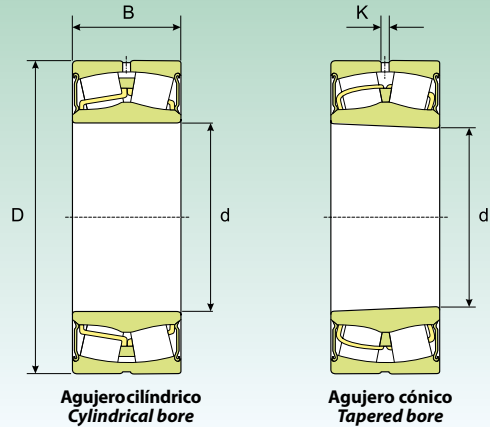

Dimensiones (mm) Dimension (mm)				Coeficiente de carga (KN) Load rating (KN)		Velocidad límite (rpm)	Peso (Kg) Weight (Kg)	Sigla Designation	
d (mm)	D (mm)	B (mm)	K (mm)	Dinámico Dynamic C	Estático Static C ₀	Speed limit (Rpm)		Agujero cilíndrico Cylindrical bore	Agujero Cónico Tapered bore
25	52	23	2	48.02	43.12	3060	0.31	22205-2RS*	-
30	62	25	2	62.72	58.8	2380	0.34	22206-2RS*	-
35	72	28	2	84.77	83.3	2040	0.52	22207-2RS*	-
40	80	28	3	94.57	88.2	1870	0.57	22208-2RS*	22208-2RSK
	90	38	3	147	137.2	1615	1.2	22308-2RS	-
45	85	28	3	99.96	96.04	1700	0.66	22209-2RS*	22209-2RSK
50	90	28	3	101.92	105.84	1615	0.7	22210-2RS*	22210-2RSK
55	100	31	3	122.5	124.46	1445	1	22211-2RS*	22211-2RSK
	120	49	3	264.6	274.4	1190	2.8	22311-2RS	-
60	110	34	3	152.88	162.68	1360	1.3	22212-2RS*	22212-2RSK
65	120	38	3	189.14	211.68	1275	1.6	22213-2RS*	22213-2RSK
70	125	38	3	203.84	223.44	1190	1.8	22214-2RS*	22214-2RSK
75	130	38	3	207.76	235.2	1105	2.1	22215-2RS*	22215-2RSK
	160	64	4.5	431.2	465.5	807.5	6.5	22315-2RS	-
80	140	40	3	231.28	264.6	1020	2.4	22216-2RS*	22216-2RSK
85	150	44	3	279.3	318.5	935	3	22217-2RS*	22217-2RSK
90	160	48	3	318.5	367.5	850	3.7	22218-2RS*	22218-2RSK
100	180	55	4.5	416.5	480.2	765	5.5	22220-2RS*	-
110	170	45	4.5	303.8	431.2	765	3.75	23022-2RS	-
	180	56	4.5	421.4	573.3	680	5.55	23122-2RS	-
	180	69	3	509.6	735	535.5	6.85	24122-2RS	-
	200	63	4.5	548.8	627.2	680	7.6	22222-2RS*	-
120	180	46	3	347.9	499.8	722.5	4.2	23024-2RS	-
	180	60	3	421.4	656.6	569.5	5.45	24024-2RS	-
	200	80	3	641.9	931	476	10.5	24124-2RS	-
	215	69	6	617.4	749.7	637.5	9.75	22224-2RS*	-
130	200	52	4.5	421.4	597.8	680	6	23026-2RS	-
	200	69	3	529.2	798.7	510	8.05	24026-2RS	-
	210	80	3	666.4	980	450.5	11	24126-2RS	-
140	210	69	3	558.6	882	476	8.55	24028-2RS	-
	225	85	4.5	749.7	1136.8	382.5	13.5	24128-2RS	-
	250	88	6	896.7	1225	450.5	19.5	23228-2RS	-
150	225	75	3	641.9	1019.2	450.5	10.5	24030-2RS	-
	250	100	4.5	999.6	1499.4	340	20	24130-2RS	-
160	240	80	4.5	735	1176	382.5	13	24032-2RS	-
	270	86	7.5	960.4	1342.6	450.5	20.5	23132-2RS	-

* Equivalente SKF BS2-22.-2CS
 * SKF Equivalent BS2-22.-2CS

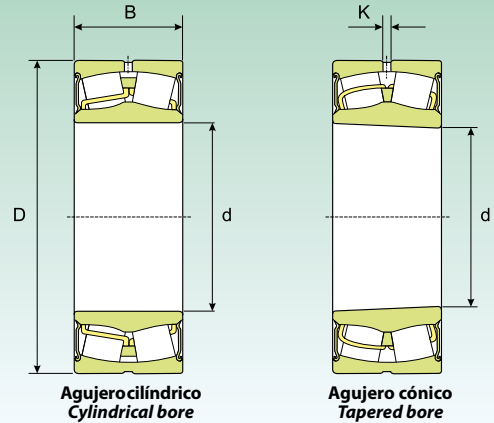
RODAMIENTOS DE RODILLOS A RÓTULA BLINDADOS
SEALED SELF-ALIGNING ROLLER BEARINGS

Dimensiones (mm) Dimension (mm)				Coeficiente de carga (KN) Load rating (KN)		Velocidad límite (rpm)	Peso (Kg) Weight (Kg)	Sigla Designation	
d (mm)	D (mm)	B (mm)	K (mm)	Dinámico Dynamic C	Estático Static C ₀	Speed limit (Rpm)		Agujero cilíndrico Cylindrical bore	Agujero Cónico Tapered bore
170	260	90	4.5	911.4	1430.8	340	17.5	24034-2RS	-
	280	109	4.5	1195.6	1822.8	306	27.5	24134-2RS	-
180	280	100	4.5	1058.4	1695.4	323	23	24036-2RS	-
190	320	128	6	1568	2450	289	43	24138-2RS	-
200	340	140	6	1764	2744	272	53.5	24140-2RS	-
	360	128	9	1822.8	2646	365.5	58	23240-2RS	-
220	300	60	4.5	535.08	1059	510	12.5	23944-2RS	-

RODAMIENTOS DE RODILLOS A RÓTULA PARA APLICACIONES VIBRATORIAS
SELF-ALIGNING ROLLER VIBRATING SCREEN BEARINGS

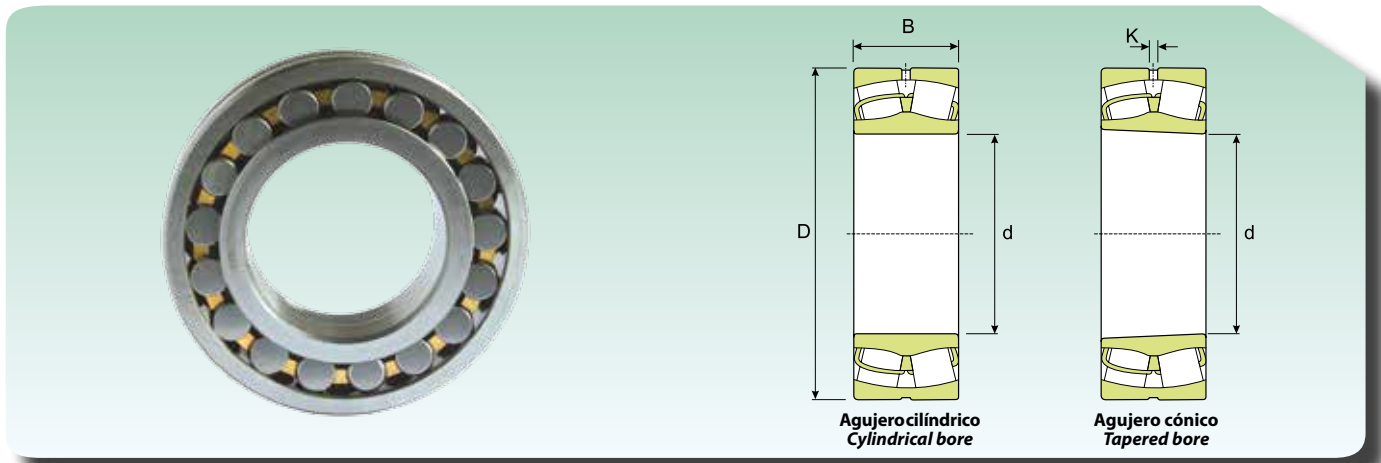

Dimensiones (mm) Dimension (mm)				Coeficiente de carga (KN) Load rating (KN)		Velocidad límite (rpm) Speed limit (Rpm)		Peso (Kg) Weight (Kg)	Sigla Designation	
d (mm)	D (mm)	B (mm)	K (mm)	Dinámico Dynamic C	Estático Static C ₀	Lubricación Lubrication			Agujero cilíndrico Cylindrical bore	Agujero Cónico Tapered bore
						Grasa Grease	Aceite Oil			
40	90	33	3	147	137	6120	7200	1.05	22308 VA	-
45	100	36	3	179	179	5355	6300	1.4	22309 VA	-
50	110	40	3	216	220	4820	5670	1.9	22310 VA	-
55	120	43	3	265	274	4284	5040	2.45	22311 VA	22311 KVA
60	130	46	4.5	304	328	4055	4770	3.1	22312 VA	22312 KVA
65	140	48	4.5	333	353	3825	4500	3.75	22313 VA	22313 KVA
70	150	51	4.5	392	421	3443	4050	4.55	22314 VA	22314 KVA
75	160	55	4.5	431	466	3290	3870	5.55	22315 VA	22315 KVA
80	170	58	4.5	480	529	3060	3600	6.6	22316 VA	22316 KVA
85	180	60	4.5	539	608	2907	3420	7.65	22317 VA	22317 KVA
90	190	64	6	598	681	2754	3240	9.05	22318 VA	22318 KVA
95	200	67	6	657	750	2601	3060	10.5	22319 VA	22319 KVA
100	215	73	6	799	931	2295	2700	13.5	22320 VA	22320 KVA
110	240	80	7.5	931	1098	2142	2520	18.4	22322 VA	22322 KVA
120	260	86	7.5	946	1098	1989	2340	23	22324 VA	22324 KVA
130	280	93	9	1098	1294	1836	2160	29	22326 VA	22326 KVA
140	300	102	9	1264	1529	1683	1980	36.5	22328 VA	22328 KVA
150	320	108	9	1431	1725	1530	1800	43.5	22330 VA	22330 KVA
160	340	114	9	1568	1921	1454	1710	52	22332 VA	22332 KVA
170	360	120	9	1725	2117	1377	1620	61	22334 VA	22334 KVA
180	380	126	12	1960	2401	1301	1530	71.5	22336 VA	22336 KVA
190	400	132	12	2078	2597	1224	1440	82.5	22338 VA	22338 KVA
200	420	138	12	2274	2842	1148	1350	95	22340 VA	22340 KVA
220	460	145	12	2646	3381	1071	1260	120	22344 VA	22344 KVA
240	500	155	12	3038	3920	995	1170	155	22348 VA	22348 KVA

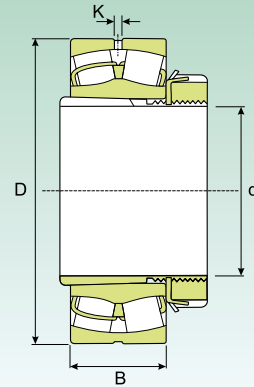
**RODAMIENTOS DE RODILLOS A RÓTULA CON MANGUITO DE FIJACIÓN
SELF-ALIGNING ROLLER BEARINGS WITH ADAPTER SLEEVE**

Dimensiones (mm) Dimension (mm)					Coeficiente de carga (KN) Load rating (KN)		Velocidad límite (rpm) Speed limit (Rpm)		Peso (Kg) Weight (Kg)	Sigla Designation	
d (mm)	D (mm)	B (mm)	K (mm)	B1 (mm)	Dinámico Dynamic C	Estático Static C ₀	Lubrificación Lubrication			Rodamiento Bearing	Manguito de tracción Adapters sleeve
							Grasa Grease	Aceite Oil			
20	52	18	2	29	48	43	13005	15300	0.33	22205 EKW33	H 305
25	62	20	2	31	63	59	10710	12600	0.39	22206 EKW33	H 306
	72	19	-	31	54	60	7650	9000	0.51	21306 EKW33	H 306
30	72	23	2	53	85	83	9180	10800	0.59	22207 EKW33	H 307
	80	21	-	35	64	71	7268	8550	0.69	21307 EKW33	H 307
35	80	23	3	36	95	88	8415	9900	0.68	22208 EKW33	H 308
	90	23	3	36	102	106	7268	8550	0.92	21308 EKW33	H 308
	90	33	3	46	147	137	6120	7200	1.25	22308 EKW33	H 2308
40	85	23	3	39	100	96	7650	9000	0.81	22209 EKW33	H 309
	100	25	3	39	123	124	6503	7650	1.2	21309 EKW33	H 309
	100	36	3	50	179	179	5355	6300	1.7	22309 EKW33	H 2309
45	90	23	3	42	102	106	7268	8550	0.9	22210 EKW33	H 310
	110	27	3	42	153	163	5738	6750	1.6	21310 EKW33	H 310
	110	40	3	55	216	220	4820	5670	2.25	22310 EKW33	H 2310
50	100	25	3	45	123	124	6503	7650	1.1	22211 EKW33	H 311
	120	29	3	45	153	163	5738	6750	1.95	21311 EKW33	H 311
	120	43	3	59	265	274	4284	5040	2.85	22311 EKW33	H 2311
55	110	28	3	47	153	163	5738	6750	1.45	22212 EKW33	H 312
	130	31	3	47	208	235	4820	5670	2.35	21312 EKW33	H 312
	130	46	4.5	62	304	328	4055	4770	3.5	22312 EKW33	H 2312
60	120	31	3	50	189	212	5355	6300	1.95	22213 EKW33	H 313
	140	33	3	50	231	265	4590	5400	2.9	21313 EKW33	H 313
	140	48	4.5	65	333	353	3825	4500	4.2	22313 EKW33	H 2313
65	130	31	3	55	208	235	4820	5670	2.45	22215 EKW33	H 315
	160	37	3	55	279	319	4284	5040	4.5	21315 EKW33	H 315
	160	55	4.5	73	431	466	3290	3870	6.5	22315 EKW33	H 2315
70	140	33	3	59	231	265	4590	5400	3	22216 EKW33	H 316
	170	39	3	59	319	368	4055	4770	5.3	21316 EKW33	H 316
	170	58	4.5	78	480	529	3060	3600	7.65	22316 EKW33	H 2316
75	150	36	3	63	279	319	4284	5040	3.7	22217 EKW33	H 317
	180	41	3	63	319	368	4055	4770	6.2	21317 EKW33	H 317
	180	60	4.5	82	539	608	2907	3420	8.85	22317 EKW33	H 2317
80	160	40	3	65	319	368	4055	4770	4.55	22218 EKW33	H 318
	160	52.4	3	86	348	431	2907	3420	6	23218 EKW33	H 2318
	190	43	4.5	65	372	441	3672	4320	7.25	21318 EKW33	H 318
	190	64	6	86	598	681	2754	3240	10.5	22318 EKW33	H 2318
85	170	43	4.5	68	372	441	3672	4320	5.45	22219 EKW33	H 319
	200	45	4.5	68	417	480	3443	4050	8.25	21319 EKW33	H 319
	200	67	6	90	657	750	2601	3060	12	22319 EKW33	H 2319

RODAMIENTOS DE RODILLOS A RÓTULA CON MANGUITO DE FIJACIÓN
SELF-ALIGNING ROLLER BEARINGS WITH ADAPTER SLEEVE

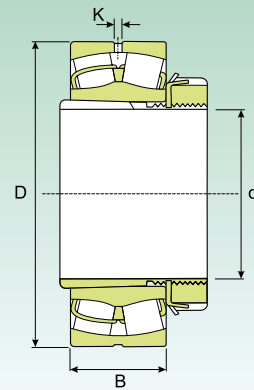

Dimensiones (mm) Dimension (mm)					Coeficiente de carga (KN) Load rating (KN)		Velocidad límite (rpm) Speed limit (Rpm)		Peso (Kg) Weight (Kg)	Sigla Designation	
d (mm)	D (mm)	B (mm)	K (mm)	B1 (mm)	Dinámico Dynamic C	Estático Static C ₀	Lubricación Lubrication			Rodamiento Bearing	Manguito de tracción Adapters sleeve
							Grasa Grease	Aceite Oil			
90	165	52	3	76	358	480	3060	3600	6.15	23120 EKW33	H 3120
	180	46	4.5	71	417	480	3443	4050	6.4	22220 EKW33	H 320
	180	60.3	4.5	97	466	588	2601	3060	8.75	23220 EKW33	H 2320
	215	47	4.5	71	417	480	3443	4050	10.5	21320 EKW33	H 320
	215	73	6	97	799	931	2295	2700	15.2	22320 EKW33	H 2320
100	170	45	3	77	304	431	3290	3870	5.75	23022 EKW33	H 322
	180	56	4.5	81	421	573	2754	3240	7.7	23122 EKW33	H 3122
	200	53	4.5	77	549	627	3060	3600	8.9	22222 EKW33	H 322
	200	69.8	4.5	105	588	750	2448	2880	12.5	23222 EKW33	H 2322
	240	80	7.5	105	931	1098	2142	2520	21	22322 EKW33	H 2322
110	180	46	3	72	348	500	3060	3600	5.95	23024 EKW33	H 3024
	200	62	4.5	88	500	681	2601	3060	10	23124 EKW33	H 3124
	215	58	6	88	617	750	2907	3420	11	22224 EKW33	H 3124
	215	76	4.5	112	681	911	2142	2520	14.7	23224 EKW33	H 2324
	260	86	7.5	112	946	1098	1989	2340	25.5	22324 EKW33	H 2324
115	200	52	4.5	80	421	598	2754	3240	8.6	23026 EKW33	H 3026
	210	64	4.5	92	549	764	2448	2880	12	23126 EKW33	H 3126
	230	64	6	92	720	911	2754	3240	14	22226 EKW33	H 3126
	230	80	4.5	121	764	1039	1989	2340	18.5	23226 EKW33	H 2326
	280	93	9	121	1098	1294	1836	2160	33	22326 EKW33	H 2326
125	210	53	4.5	82	456	666	2601	3060	9.4	23028 EKW33	H 3028
	225	68	4.5	97	617	882	2142	2520	14.3	23128 EKW33	H 3128
	250	68	6	97	696	882	2448	2880	17.8	22228 EKW33	H 3128
	250	88	6	131	897	1225	1836	2160	24	23228 EKW33	H 2328
	300	102	9	131	1264	1529	1683	1980	41	22328 EKW33	H 2328
135	225	56	4.5	87	500	735	2448	2880	11	23030 EKW33	H 3030
	250	80	6	111	813	1176	1989	2340	20.8	23130 EKW33	H 3130
	270	73	7.5	111	833	1058	2295	2700	22.8	22230 EKW33	H 3130
	270	96	6	139	1058	1431	1683	1980	30	23230 EKW33	H 2330
	320	108	9	139	1431	1725	1530	1800	47.4	22330 EKW33	H 2330
140	240	60	6	93	573	862	2295	2700	14.5	23032 EKW33	H 3032
	270	86	7.5	119	960	1343	1836	2160	27.3	23132 EKW33	H 3132
	290	80	7.5	119	980	1264	2142	2520	29.3	22232 EKW33	H 3132
	290	104	7.5	147	1196	1627	1683	1980	38.8	23232 EKW33	H 2332
	340	114	9	147	1568	1921	1454	1710	60	22332 EKW33	H 2332
150	260	67	6	101	696	1039	2142	2520	18.3	23034 EKW33	H 3034
	280	88	7.5	122	1019	1470	1836	2160	29.5	23134 EKW33	H 3134
	310	86	9	122	1098	1431	1989	2340	36	22234 EKW33	H 3134
	310	110	7.5	154	1372	1891	1530	1800	46.4	23234 EKW33	H 2334
	360	120	9	154	1725	2117	1377	1620	69.5	22334 EKW33	H 2334

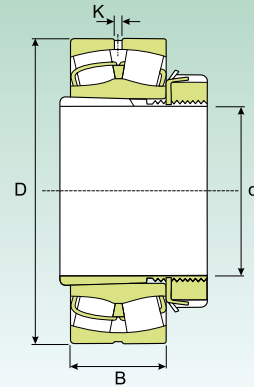
**RODAMIENTOS DE RODILLOS A RÓTULA CON MANGUITO DE FIJACIÓN
SELF-ALIGNING ROLLER BEARINGS WITH ADAPTER SLEEVE**

Dimensiones (mm) Dimension (mm)					Coeficiente de carga (KN) Load rating (KN)		Velocidad límite (rpm) Speed limit (Rpm)		Peso (Kg) Weight (Kg)	Sigla Designation	
d (mm)	D (mm)	B (mm)	K (mm)	B1 (mm)	Dinámico Dynamic C	Estático Static C ₀	Lubricación Lubrication			Rodamiento Bearing	Manguito de tracción Adapters sleeve
							Grasa Grease	Aceite Oil			
160	250	52	3	87	422	813	2142	2520	13.4	23936 EKW33	H 3936
	280	74	7.5	109	813	1225	1989	2340	23.2	23036 EKW33	H 3036
	300	96	7.5	131	1176	1725	1683	1980	37	23136 EKW33	H 3136
	320	86	9	131	1156	1529	1989	2340	38.2	22236 EKW33	H 3136
	320	112	7.5	161	1470	2078	1454	1710	49.5	23236 EKW33	H 2336
	380	126	12	161	1960	2401	1301	1530	80	22336 EKW33	H 2336
170	260	52	9	89	406	784	1989	2340	14.5	23938 EKW33	H 3938
	290	75	7.5	112	848	1313	1836	2160	24.8	23038 EKW33	H 3038
	320	104	7.5	141	1343	2038	1530	1800	44.5	23138 EKW33	H 3138
	340	92	9	141	1245	1666	1836	2160	46	22238 EKW33	H 3138
	340	120	9	169	1627	2352	1377	1620	59	23238 EKW33	H 2338
	400	132	12	169	2078	2597	1224	1440	93	22338 EKW33	H 2338
180	280	60	4.5	98	535	1019	1836	2160	19	23940 EKW33	H 3940
	310	82	7.5	120	980	1499	1683	1980	31.7	23040 EKW33	H 3040
	340	112	9	150	1568	2313	1454	1710	55.5	23140 EKW33	H 3140
	360	98	9	150	1431	1891	1683	1980	66	22240 EKW33	H 3140
	360	128	9	176	1823	2646	1301	1530	70	23240 EKW33	H 2340
	420	138	12	176	2274	2842	1148	1350	107	22340 EKW33	H 2340
200	300	60	4.5	96	535	1058	1683	1980	22.5	23944 EKW33	OH 3944 H
	340	90	7.5	126	1196	1823	1530	1800	39.4	23044 EKW33	OH 3044 H
	370	120	9	161	1764	2695	1301	1530	67.5	23144 EKW33	OH 3144 H
	400	108	9	161	1725	2313	1530	1800	74	22244 EKW33	OH 3144 H
	400	144	9	186	2313	3381	1148	1350	96.5	23244 EKW33	OH 2344 H
	460	145	12	186	2646	3381	1071	1260	135	22344 EKW33	OH 2344 H
220	320	60	4.5	101	553	1137	1530	1800	24.5	23948 EKW33	OH 3948 H
	360	92	7.5	133	1264	2038	1454	1710	44.5	23048 EKW33	OH 3048 H
	400	128	9	172	2038	3136	1224	1440	80.5	23148 EKW33	OH 3148 H
	440	120	12	172	2156	2940	1377	1620	99	22248 EKW33	OH 3148 H
	440	160	12	199	2842	4214	995	1170	125	23248 EKW33	OH 2348 H
	500	155	12	199	3038	3920	995	1170	170	22348 EKW33	OH 2348 H
240	360	75	4.5	116	862	1764	1454	1710	35	23952 EKW33	OH 3952 H
	400	104	9	145	1568	2499	1301	1530	60.5	23052 EKW33	OH 3052 H
	440	144	9	190	2499	3822	1071	1260	109	23152 EKW33	OH 3152 H
	480	130	12	190	2597	3479	1224	1440	130	22252 EKW33	OH 3152 H
	480	174	12	211	3185	4655	918	1080	160	23252 EKW33	OH 2352 H
	540	165	12	211	3479	4459	842	990	215	22352 EKW33	OH 2352 H
260	380	75	6	121	828	1725	1301	1530	40	23956 EKW33	OH 3956 H
	420	106	9	152	1695	2793	1224	1440	67	23056 EKW33	OH 3056 H
	460	146	9	195	2597	4165	995	1170	115	23156 EKW33	OH 3156 H
	500	130	12	195	2646	3675	1148	1350	135	22256 EKW33	OH 3156 H
	500	176	12	224	3185	4802	842	990	165	23256 EKW33	OH 2356 H
	580	175	12	224	3920	5096	842	990	250	22356 EKW33	OH 2356 H

RODAMIENTOS DE RODILLOS A RÓTULA CON MANGUITO DE FIJACIÓN
SELF-ALIGNING ROLLER BEARINGS WITH ADAPTER SLEEVE

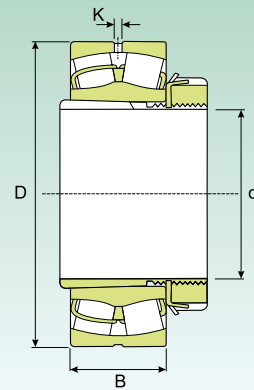

Dimensiones (mm) Dimension (mm)					Coeficiente de carga (KN) Load rating (KN)		Velocidad límite (rpm) Speed limit (Rpm)		Peso (Kg) Weight (Kg)	Sigla Designation	
d (mm)	D (mm)	B (mm)	K (mm)	B1 (mm)	Dinámico Dynamic C	Estático Static C ₀	Lubricación Lubrication			Rodamiento Bearing	Manguito de tracción Adapters sleeve
							Grasa Grease	Aceite Oil			
280	420	90	6	140	1176	2450	1224	1440	58.5	23960 EKW33	OH 3960 H
	460	118	9	168	2078	3381	1148	1350	90	23060 EKW33	OH 3060 H
	500	160	9	208	3136	4998	918	1080	150	23160 EKW33	OH 3160 H
	540	140	12	208	3087	4165	1071	1260	170	22260 EKW33	OH 3160 H
	540	192	12	240	3822	5733	765	900	210	23260 EKW33	OH 3260 H
300	440	90	6	140	1401	2646	1148	1350	61	23964 EKW33	OH 3964 H
	480	121	9	171	2195	3724	1071	1260	97	23064 EKW33	OH 3064 H
	540	176	12	226	3675	5880	842	990	185	23164 EKW33	OH 3164 H
	580	150	12	226	3528	4802	995	1170	200	22264 EKW33	OH 3164 H
	580	208	12	258	4312	6566	727	855	260	23264 EKW33	OH 3264 H
320	460	90	6	144	1431	2744	1071	1260	67.5	23968 EKW33	OH 3968 H
	520	133	12	187	2646	4459	995	1170	130	23068 EKW33	OH 3068 H
	580	190	12	254	4165	6664	765	900	250	23168 EKW33	OH 3168 H
	620	224	12	288	4998	7644	612	720	335	23268 EKW33	OH 3268 H
340	480	90	6	144	1372	2695	995	1170	70.5	23972 EKW33	OH 3972 H
	540	134	12	188	2695	4704	918	1080	135	23072 EKW33	OH 3072 H
	600	192	12	259	4214	6811	765	900	260	23172 EKW33	OH 3172 H
	650	170	12	259	4214	6076	650	765	375	22272 EKW33	OH 3172 H
	650	232	12	299	5292	8134	574	675	375	23272 EKW33	OH 3272 H
360	520	106	7.5	164	1921	3724	918	1080	95	23976 EKW33	OH 3976 H
	560	135	12	193	2842	4900	918	1080	145	23076 EKW33	OH 3076 H
	620	194	12	264	4312	6958	765	900	275	23176 EKW33	OH 3176 H
	680	240	12	310	5733	8967	574	675	420	23276 EKW33	OH 3276 H
380	540	106	7.5	168	1960	3822	918	1080	100	23980 EKW33	OH 3980 H
	600	148	12	210	3185	5586	842	990	180	23080 EKW33	OH 3080 H
	650	200	12	272	4557	7497	727	855	325	23180 EKW33	OH 3180 H
	720	256	12	328	6419	10192	513	603	505	23280 EKW33	OH 3280 H
	820	243	12	328	7350	10192	574	675	735	22380 EKW33	OH 3280 H
400	560	106	9	168	1999	4067	842	990	105	23984 EKW33	OH 3984 H
	620	150	12	212	3332	5880	842	990	190	23084 EKW33	OH 3084 H
	700	224	12	304	5488	9114	689	810	410	23184 EKW33	OH 3184 H
	760	272	12	352	7203	11368	482	567	590	23284 EKW33	OH 3284 H
410	600	118	9	189	2401	4802	765	900	150	23988 EKW33	OH 3988 H
	650	157	12	228	3577	6419	765	900	235	23088 EKW33	OH 3088 H
	720	226	12	307	5880	9800	650	765	430	23188 EKW33	OH 3188 H
	790	280	12	361	7644	12250	459	540	670	23288 EKW33	OH 3288 H
430	620	118	9	189	2450	4900	765	900	160	23992 EKW33	OH 3992 H
	680	163	12	234	3822	6811	727	855	265	23092 EKW33	OH 3092 H
	760	240	12	326	6272	10584	612	720	530	23192 EKW33	OH 3192 H
	830	296	12	382	8330	13426	428	504	790	23292 EKW33	2OH 3292 H
450	650	128	9	200	2842	5586	765	900	185	23996 EKW33	OH 3996 H
	700	165	12	237	3822	6664	727	855	275	23096 EKW33	OH 3096 H
	790	248	12	335	6811	11760	574	675	590	23196 EKW33	OH 3196 H
	870	310	12	397	9114	14700	405	477	935	23296 EKW33	OH 3296 H

**RODAMIENTOS DE RODILLOS A RÓTULA CON MANGUITO DE FIJACIÓN
SELF-ALIGNING ROLLER BEARINGS WITH ADAPTER SLEEVE**

Dimensiones (mm) Dimension (mm)					Coeficiente de carga (KN) Load rating (KN)		Velocidad límite (rpm) Speed limit (Rpm)		Peso (Kg) Weight (Kg)	Sigla Designation	
d (mm)	D (mm)	B (mm)	K (mm)	B1 (mm)	Dinámico Dynamic C	Estático Static C ₀	Lubricación Lubrication			Rodamiento Bearing	Manguito de tracción Adapters sleeve
						Grasa Grease	Aceite Oil				
470	670	128	12	208	2842	5880	727	855	195	239/500 EKW33	OH 39/500 H
	720	167	12	247	4067	7644	689	810	290	230/500 EKW33	OH 30/500 H
	830	264	12	356	7497	12642	536	630	690	231/500 EKW33	OH 31/500 H
	920	336	12	428	10388	16954	383	450	1100	232/500 EKW33	OH 32/500 H
500	710	136	12	216	3136	6566	689	810	255	239/530 EKW33	OH 39/530 H
	780	185	12	265	4998	9114	612	720	405	230/530 EKW33	OH 30/530 H
	870	272	12	364	7987	13720	513	603	785	231/530 EKW33	OH 31/530 H
	980	355	12	447	10878	19992	367	432	1360	232/530 EKW33	OH 32/530 H
530	750	140	12	227	3381	7056	612	765	260	239/560 EKW33	OH 39/560 H
	820	195	12	282	5488	9996	540	675	445	230/560 EKW33	OH 30/560 H
	920	280	12	377	8967	15680	453.6	567	880	231/560 EKW33	OH 31/560 H
	1030	365	12	462	11270	21560	309.6	387	1490	232/560 EKW33	OH 32/560 H
560	800	150	12	239	3822	8134	540	675	330	239/600 EKW33	OH 39/600 H
	870	200	12	289	5880	11172	504	630	525	230/600 EKW33	OH 30/600 H
	980	300	12	399	9996	17640	403.2	504	1070	231/600 EKW33	OH 31/600 H
	1090	388	12	487	12838	24990	288	360	1780	232/600 EKW33	OH 32/600 H
600	850	165	12	254	4557	9604	504	630	385	239/630 EKW33	OH 39/630 H
	920	212	12	301	6566	12250	482.4	603	595	230/630 EKW33	OH 30/630 H
	1030	315	12	424	10290	20384	381.6	477	1240	231/630 EKW33	OH 31/630 H
630	900	170	12	264	4900	10584	482.4	603	455	239/670 EKW33	OH 39/670 H
	980	230	12	324	7497	14308	432	540	755	230/670 EKW33	OH 30/670 H
	1090	336	12	456	10682	21952	360	450	1510	231/670 EKW33	OH 31/670 H
	1220	438	12	558	15092	29890	259.2	324	2535	232/670 EKW33	OH 32/670 H
670	950	180	12	286	5488	11760	432	540	525	239/710 EKW33	OH 39/710 H
	1030	236	12	342	8134	15974	403.2	504	860	230/710 EKW33	OH 30/710 H
	1150	345	12	467	11956	25480	324	405	1750	231/710 EKW33	OH 31/710 H
	1280	450	12	572	17248	33810	230.4	288	2995	232/710 EKW33	OH 32/710 H
710	1000	185	12	291	5880	12936	403.2	504	605	239/750 EKW33	OH 39/750 H
	1090	250	12	356	9457	18228	381.6	477	990	230/750 EKW33	OH 30/750 H
	1220	365	12	493	13524	28420	309.6	387	2045	231/750 EKW33	OH 31/750 H
	1360	475	12	603	18326	35770	216	270	3485	232/750 EKW33	OH 32/750 H
750	1060	195	12	303	6272	14014	381.6	477	730	239/800 EKW33	OH 39/800 H
	1150	258	12	366	9800	19600	345.6	432	1200	230/800 EKW33	OH 30/800 H
	1280	375	12	505	14504	30870	288	360	2430	231/800 EKW33	OH 31/800 H
800	1120	200	12	308	6811	15288	345.6	432	950	239/850 EKW33	OH 39/850 H
	1220	272	12	380	9182.6	21168	324	405	1390	230/850 EKW33	OH 30/850 H
	1360	400	12	536	15778	33810	259.2	324	2800	231/850 EKW33	OH 31/850 H
850	1180	206	12	326	7350	16660	324	405	930	239/900 EKW33	OH 39/900 H
	1280	280	12	400	9898	22736	288	360	1580	230/900 EKW33	OH 30/900 H
900	1250	224	12	344	7105	19208	309.6	387	1120	239/950 EKW33	OH 39/950 H
	1360	300	12	420	11760	27930	273.6	342	1870	230/950 EKW33	OH 30/950 H

RODAMIENTOS DE RODILLOS A RÓTULA CON MANGUITO DE FIJACIÓN
SELF-ALIGNING ROLLER BEARINGS WITH ADAPTER SLEEVE

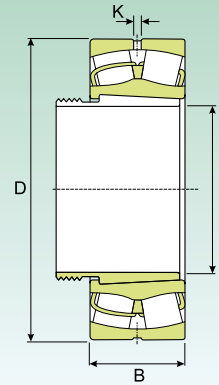

Dimensiones (mm) Dimension (mm)					Coeficiente de carga (KN) Load rating (KN)		Velocidad límite (rpm) Speed limit (Rpm)		Peso (Kg) Weight (Kg)	Sigla Designation	
d (mm)	D (mm)	B (mm)	K (mm)	B1 (mm)	Dinámico Dynamic C	Estático Static C ₀	Lubrificación Lubrication			Rodamiento Bearing	Manguito de tracción Adapters sleeve
							Grasa Grease	Aceite Oil			
950	1420	308	12	430	12446	29890	259.2	324	2070	230/1000 EKW33	OH 30/1000 H
	1580	462	12	609	20972	47040	201.6	252	4340	231/1000 EKW33	OH 31/1000 H
1000	1400	250	12	372	9359	25480	259.2	324	1590	239/1060 EKW33	OH 39/1060 H
	1500	325	12	447	13524	33320	230.4	288	2800	230/1060 EKW33	OH 30/1060 H

**RODAMIENTOS DE RODILLOS A RÓTULA SOBRE MANGUITO DE DESMONTAJE
SELF-ALIGNING ROLLER BEARINGS WITH WITHDRAWAL SLEEVE**

Dimensiones (mm) Dimension (mm)				Coeficiente de carga (KN) Load rating (KN)		Velocidad límite (rpm) Speed limit (Rpm)		Peso (Kg) Weight (Kg)	Sigla Designation	
d (mm)	D (mm)	B (mm)	K (mm)	Dinámico Dynamic C	Estático Static C ₀	Lubrificación Lubrication			Rodamiento Bearing	Manguito de desmontaje Withdrawal sleeve
						Grasa Grease	Aceite Oil			
35	80	23	3	95	88	8415.00	9900	0.6	22208 K	AH 308
	90	23	3	102	106	7267.50	8550	0.84	21308 K	AH 308
	90	33	3	147	137	6120.00	7200	1.2	22308 K	AH 2308
40	85	23	3	100	96	7650.00	9000	0.7	22209 K	AH 309
	100	25	3	123	124	6502.50	7650	1.1	21309 K	AH 309
	100	36	3	179	179	5355.00	6300	1.55	22309 K	AH 2309
45	90	23	3	102	106	7267.50	8550	0.75	22210 K	AHX 310
	110	27	3	153	163	5737.50	6750	1.45	21310 K	AHX 310
	110	40	3	216	220	4819.50	5670	2.1	22310 K	AHX 2310
50	100	25	3	123	124	6502.50	7650	0.95	22211 K	AHX 311
	120	29	3	153	163	5737.50	6750	1.8	21311 K	AHX 311
	120	43	3	265	274	4284.00	5040	2.7	22311 K	AHX 2311
55	110	28	3	153	163	5737.50	6750	1.3	22212 K	AHX 312
	130	31	3	208	235	4819.50	5670	2.2	21312 K	AHX 312
	130	46	4.5	304	328	4054.50	4770	3.3	22312 K	AHX 2312
60	120	31	3	189	212	5355.00	6300	1.7	22213 K	AH 313
	140	33	3	231	265	4590.00	5400	2.75	21313 K	AH 313
	140	48	4.5	333	353	3825.00	4500	4.1	22313 K	AH 2313
65	125	31	3	204	223	5125.50	6030	1.8	22214 K	AH 314
	150	35	3	279	319	4284.00	5040	3.35	21314 K	AH 314
	150	51	4.5	392	421	3442.50	4050	4.9	22314 K	AHX 2314
70	130	31	3	208	235	4819.50	5670	1.95	22215 K	AH 315
	160	37	3	279	319	4284.00	5040	4.15	21315 K	AH 315
	160	55	4.5	431	466	3289.50	3870	6	22315 K	AHX 2315
75	140	33	3	231	265	4590.00	5400	2.4	22216 K	AH 316
	170	39	3	319	368	4054.50	4770	4.75	21316 K	AH 316
	170	58	4.5	480	529	3060.00	3600	7	22316 K	AHX 2316
80	150	36	3	279	319	4284.00	5040	3.05	22217 K	AHX 317
	180	41	3	319	368	4054.50	4770	5.55	21317 K	AHX 317
	180	60	4.5	539	608	2907.00	3420	8.15	22317 K	AHX 2317
85	160	40	3	319	368	4054.50	4770	3.7	22218 K	AHX 318
	160	52.4	3	348	431	2907.00	3420	5	23218 EKW33	AHX 3218
	190	43	4.5	372	441	3672.00	4320	6.4	21318 K	AHX 318
	190	64	6	598	681	2754.00	3240	9.5	22318 K	AHX 2318
90	170	43	4.5	372	441	3672.00	4320	4.6	22219 K	AHX 319
	200	45	4.5	417	480	3442.50	4050	7.4	21319 K	AHX 319
	200	67	6	657	750	2601.00	3060	11	22319 K	AHX 2319
95	165	52	3	358	480	3060.00	3600	5	23120 EKW33	AHX 3120
	180	46	4.5	417	480	3442.50	4050	5.4	22220 K	AHX 320
	180	60.3	4.5	466	588	2601.00	3060	7.3	23220 EKW33	AHX 3220
	215	47	4.5	417	480	3442.50	4050	9.1	21320 K	AHX 320
	215	73	6	799	931	2295.00	2700	14	22320 K	AHX 2320

RODAMIENTOS DE RODILLOS A RÓTULA SOBRE MANGUITO DE DESMONTAJE
SELF-ALIGNING ROLLER BEARINGS WITH WITHDRAWAL SLEEVE

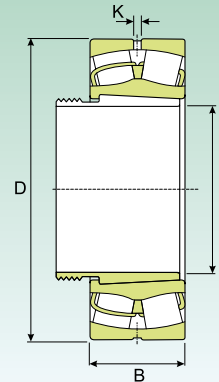

Dimensiones (mm) Dimension (mm)				Coeficiente de carga (KN) Load rating (KN)		Velocidad límite (rpm) Speed limit (Rpm)		Peso (Kg) Weight (Kg)	Sigla Designation	
d (mm)	D (mm)	B (mm)	K (mm)	Dinámico Dynamic C	Estático Static C ₀	Lubrificación Lubrication			Rodamiento Bearing	Manguito de desmontaje Withdrawal sleeve
						Grasa Grease	Aceite Oil			
105	170	45	3	304	431	3289.50	3870	4.45	23022 EKW33	AH 322
	180	56	4.5	421	573	2754.00	3240	6.35	23122 EKW33	AHX 3122
	180	69	3	510	735	2295.00	2700	7.7	24122 EK30W33	AH 24122
	200	53	4.5	549	627	3060.00	3600	7.5	22222 EKW33	AHX 3122
	200	69.8	4.5	588	750	2448.00	2880	10.5	23222 EKW33	AHX 3222
240	80	7.5	931	1098	2142.00	2520	19.5	22322 EKW33	AHX 2322	
115	180	46	3	348	500	3060.00	3600	4.8	23024 EKW33	AHX 3024
	180	60	3	421	657	2601.00	3060	5.95	24024 EK30W33	AH 24024
	200	62	4.5	500	681	2601.00	3060	8.7	23124 EKW33	AHX 3124
	200	80	3	642	931	1989.00	2340	10.8	24124 EK30W33	AH 24124
	215	58	6	617	750	2907.00	3420	9.55	22224 EKW33	AHX 3124
	215	76	4.5	681	911	2142.00	2520	13	23224 EKW33	AHX 3224
	260	86	7.5	946	1098	1989.00	2340	24	22324 EKW33	AHX 2324
125	200	52	4.5	421	598	2754.00	3240	6.75	23026 EKW33	AHX 3026
	200	69	3	529	799	2295.00	2700	8.65	24026 EK30W33	AH 24026
	210	64	4.5	549	764	2448.00	2880	9.6	23126 EKW33	AHX 3126
	210	80	3	666	980	1836.00	2160	11.7	24126 EK30W33	AH 24126
	230	64	6	720	911	2754.00	3240	11.6	22226 EKW33	AHX 3126
	230	80	4.5	764	1039	1989.00	2340	15.5	23226 EKW33	AHX 3226
	280	93	9	1098	1294	1836.00	2160	30.5	22326 EKW33	AHX 2326
135	210	53	4.5	456	666	2601.00	3060	7.35	23028 EKW33	AHX 3028
	210	69	3	559	882	2142.00	2520	9.2	24028 EK30W33	AH 24028
	225	68	4.5	617	882	2142.00	2520	11.5	23128 EKW33	AHX 3128
	225	85	4.5	750	1137	1836.00	2160	14.3	24128 EK30W33	AH 24128
	250	68	6	696	882	2448.00	2880	15	22228 EKW33	AHX 3128
	250	88	6	897	1225	1836.00	2160	20.5	23228 EKW33	AHX 3228
	300	102	9	1264	1529	1683.00	1980	38	22328 EKW33	AHX 2328
145	225	56	4.5	500	735	2448.00	2880	8.85	23030 EKW33	AHX 3030
	225	75	3	642	1019	1989.00	2340	11.3	24030 EK30W33	AH 24030
	250	80	6	813	1176	1989.00	2340	17	23130 EKW33	AHX 3130
	250	100	4.5	1000	1499	1683.00	1980	21	24130 EK30W33	AH 24130
	270	73	7.5	833	1058	2295.00	2700	19	22230 EKW33	AHX 3130
	270	96	6	1058	1431	1683.00	1980	26	23230 EKW33	AHX 3230
	320	108	9	1431	1725	1530.00	1800	45.5	22330 EKW33	AHX 2330
150	240	60	6	573	862	2295.00	2700	11.5	23032 EKW33	AH 3032
	240	80	4.5	735	1176	1836.00	2160	14.8	24032 EK30W33	AH 24032
	270	86	7.5	960	1343	1836.00	2160	23	23132 EKW33	AH 3132
	270	109	4.5	1156	1725	1453.50	1710	28.5	24132 EK30W33	AH 24132
	290	80	7.5	980	1264	2142.00	2520	25	22232 EKW33	AH 3132
	290	104	7.5	1196	1627	1683.00	1980	34.5	23232 EKW33	AH 3232
	340	114	9	1568	1921	1453.50	1710	56	22332 EKW33	AH 2332

**RODAMIENTOS DE RODILLOS A RÓTULA SOBRE MANGUITO DE DESMONTAJE
SELF-ALIGNING ROLLER BEARINGS WITH WITHDRAWAL SLEEVE**

Dimensiones (mm) Dimension (mm)				Coeficiente de carga (KN) Load rating (KN)		Velocidad límite (rpm) Speed limit (Rpm)		Peso (Kg) Weight (Kg)	Sigla Designation	
d (mm)	D (mm)	B (mm)	K (mm)	Dinámico Dynamic C	Estático Static C ₀	Lubrificación Lubrication			Rodamiento Bearing	Manguito de desmontaje Withdrawal sleeve
						Grasa Grease	Aceite Oil			
160	260	67	6	696	1039	2142.00	2520	15	23034 EK30W33	AH 3034
	260	90	4.5	911	1431	1836.00	2160	20	24034 EK30W33	AH 24034
	280	88	7.5	1019	1470	1836.00	2160	25	23134 EK30W33	AH 3134
	280	109	4.5	1196	1823	1453.50	1710	30	24134 EK30W33	AH 24134
	310	86	9	1098	1431	1989.00	2340	31	22234 EKW33	AH 3134
	310	110	7.5	1372	1891	1530.00	1800	41	23234 EKW33	AH 3234
	360	120	9	1725	2117	1377.00	1620	65	22334 EKW33	AH 2334
170	280	74	7.5	813	1225	1989.00	2340	19.3	23036 EKW33	AH 3036
	280	100	4.5	1058	1695	1683.00	1980	25.7	24036 EK30W33	AH 24036
	300	96	7.5	1176	1725	1683.00	1980	32	23136 EKW33	AH 3136
	300	118	6	1372	2117	1300.50	1530	37	24136 EK30W33	AH 24136
	320	86	9	1156	1529	1989.00	2340	32.5	22236 EKW33	AH 2236
	320	112	7.5	1470	2078	1453.50	1710	43.5	23236 EKW33	AH 2336
	380	126	12	1960	2401	1300.50	1530	76	22336 EKW33	AH 2336
180	290	75	7.5	848	1313	1836.00	2160	21	23038 EKW33	AH 3038
	290	100	4.5	1098	1764	1530.00	1800	27.5	24038 EK30W33	AH 24038
	320	104	7.5	1343	2038	1530.00	1800	38.5	23138 EKW33	AH 3138
	320	128	6	1568	2450	1224.00	1440	46.5	24138 EK30W33	AH 24138
	340	92	9	1245	1666	1836.00	2160	39.5	22238 EKW33	AH 2238
	340	120	9	1627	2352	1377.00	1620	52.5	23238 EKW33	AH 3238
	400	132	12	2078	2597	1224.00	1440	87.5	22338 EKW33	AH 2338
190	310	82	7.5	980	1499	1683.00	1980	26.3	23040 EKW33	AH 3040
	310	109	6	1264	2078	1453.50	1710	34.5	24040 EK30W33	AH 24040
	340	112	9	1568	2313	1453.50	1710	48.5	23140 EKW33	AH 3140
	340	140	6	1764	2744	1147.50	1350	57.5	24140 EK30W33	AH 24140
	360	98	9	1431	1891	1683.00	1980	47	22240 EKW33	AH 2240
	360	128	9	1823	2646	1300.50	1530	63	23240 EKW33	AH 3240
	420	138	12	2274	2842	1147.50	1350	100	22340 EKW33	AH 2340
200	340	90	7.5	1196	1823	1530.00	1800	36.5	23044 EKW33	AOH 3044
	340	118	6	1529	2548	1300.50	1530	47.5	24044 EK30W33	AOH 24044
	370	120	9	1764	2695	1300.50	1530	61.5	23144 EKW33	AOH 3144
	370	150	6	2078	3283	1071.00	1260	76	24144 EK30W33	AOH 24144
	400	108	9	1725	2313	1530.00	1800	68	22244 EKW33	AOH 2244
	400	144	9	2313	3381	1147.50	1350	93	23244 EKW33	AOH 2344
	460	145	12	2646	3381	1071.00	1260	130	22344 EKW33	AOH 2344
220	360	92	7.5	1264	2038	1453.50	1710	40.5	23048 EKW33	AOH 3048
	360	118	6	1568	2646	1224.00	1440	50.5	24048 EK30W33	AOH 24048
	400	128	9	2038	3136	1224.00	1440	76.5	23148 EKW33	AOH 3148
	400	160	6	2352	3822	994.50	1170	91.5	24148 EK30W33	AOH 24148
	440	120	12	2156	2940	1377.00	1620	95	22248 EKW33	AOH 2248
	440	160	12	2842	4214	994.50	1170	120	23248 EKW33	AOH 2348
	500	155	12	3038	3920	994.50	1170	165	22348 EKW33	AOH 2348

RODAMIENTOS DE RODILLOS A RÓTULA SOBRE MANGUITO DE DESMONTAJE
SELF-ALIGNING ROLLER BEARINGS WITH WITHDRAWAL SLEEVE

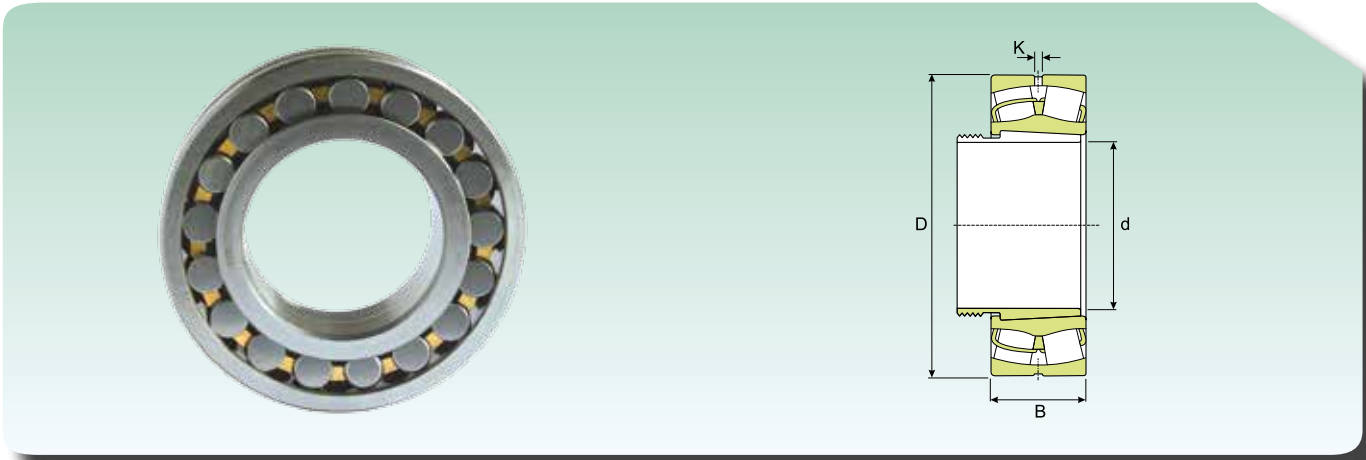

Dimensiones (mm) Dimension (mm)				Coeficiente de carga (KN) Load rating (KN)		Velocidad límite (rpm) Speed limit (Rpm)		Peso (Kg) Weight (Kg)	Sigla Designation	
d (mm)	D (mm)	B (mm)	K (mm)	Dinámico Dynamic C	Estático Static C ₀	Lubricación Lubrication			Rodamiento Bearing	Manguito de desmontaje Withdrawal sleeve
						Grasa Grease	Aceite Oil			
240	400	104	9	1568	2499	1300.50	1530	56.5	23052 EKW33	AOH 3052
	400	140	6	1999	3381	1071.00	1260	75	24052 EK30W33	AOH 24052
	440	144	9	2499	3822	1071.00	1260	105	23152 EKW33	AOH 3152
	440	180	7.5	2940	4704	918.00	1080	120	24152 EK30W33	AOH 24152
	480	130	12	2597	3479	1224.00	1440	120	22252 EKW33	AOH 2252
	480	174	12	3185	4655	918.00	1080	155	23252 EKW33	AOH 2352
	540	165	12	3479	4459	841.50	990	205	22352 EKW33	AOH 2352
260	420	106	9	1695	2793	1224.00	1440	62	23056 EKW33	AOH 3056
	420	140	6	2117	3724	1071.00	1260	79	24056 EK30W33	AOH 24056
	460	146	9	2597	4165	994.50	1170	110	23156 EKW33	AOH 3156
	460	180	7.5	3038	4998	841.50	990	130	24156 EK30W33	AOH 24156
	500	130	12	2646	3675	1147.50	1350	125	22256 EKW33	AOH 2256
	500	176	12	3185	4802	841.50	990	160	23256 EKW33	AOH 2356
	580	175	12	3920	5096	841.50	990	245	22356 EKW33	AOH 2356
280	460	118	9	2078	3381	1147.50	1350	82.5	23060 EKW33	AOH 3060
	460	160	7.5	2646	4655	918.00	1080	110	24060 EK30W33	AOH 24060
	500	160	9	3136	4998	918.00	1080	140	23160 EKW33	AOH 3160
	500	200	7.5	3675	6174	765.00	900	180	24160 EK30W33	AOH 24160
	540	140	12	3087	4165	1071.00	1260	155	22260 EKW33	AOH 2260
	540	192	12	3822	5733	765.00	900	200	23260 EKW33	AOH 3260
300	480	121	9	2195	3724	1071.00	1260	89	23064 EKW33	AOH 3064
	480	160	7.5	2793	4998	918.00	1080	115	24064 EK30W33	AOH 24064
	540	176	12	3675	5880	841.50	990	175	23164 EKW33	AOH 3164
	540	218	9	4165	6958	688.50	810	225	24164 EK30W33	AOH 24164
	580	150	12	3528	4802	994.50	1170	185	22264 EKW33	AOH 2264
	580	208	12	4312	6566	726.75	855	250	23264 EKW33	AOH 3264
320	520	133	12	2646	4459	994.50	1170	120	23068 EKW33	AOH 3068
	520	180	9	3381	6076	841.50	990	160	24068 EK30W33	AOH 24068
	580	190	12	4165	6664	765.00	900	225	23168 EKW33	AOH 3168
	580	243	9	5194	8477	650.25	765	295	24168 EK30W33	AOH 24168
	620	224	12	4998	7644	612.00	720	315	23268 EKW33	AOH 3268
340	540	134	12	2695	4704	918.00	1080	125	23072 EKW33	AOH 3072
	540	180	9	3479	6419	765.00	900	165	24072 EK30W33	AOH 24072
	600	192	12	4214	6811	765.00	900	235	23172 EKW33	AOH 3172
	600	243	9	5488	9114	612.00	720	295	24172 EK30W33	AOH 24172
	650	170	12	4214	6076	650.25	765	275	22272 EKW33	AOH 3172
	650	232	12	5292	8134	573.75	675	345	23272 EKW33	AOH 3272
360	560	135	12	2842	4900	918.00	1080	135	23076 EKW33	AOH 3076
	560	180	9	3528	6664	726.75	855	170	24076 EK30W33	AOH 24076
	620	194	12	4312	6958	765.00	900	250	23176 EKW33	AOH 3176
	620	243	9	5586	9604	650.25	765	325	24176 EK30W33	AOH 24176
	680	240	12	5733	8967	573.75	675	390	23276 EKW33	AOH 3276

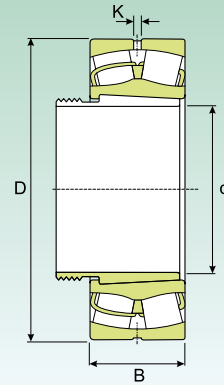
**RODAMIENTOS DE RODILLOS A RÓTULA SOBRE MANGUITO DE DESMONTAJE
SELF-ALIGNING ROLLER BEARINGS WITH WITHDRAWAL SLEEVE**

Dimensiones (mm) Dimension (mm)				Coeficiente de carga (KN) Load rating (KN)		Velocidad límite (rpm) Speed limit (Rpm)		Peso (Kg) Weight (Kg)	Sigla Designation	
d (mm)	D (mm)	B (mm)	K (mm)	Dinámico Dynamic C	Estático Static C ₀	Lubricación Lubrication			Rodamiento Bearing	Manguito de desmontaje Withdrawal sleeve
						Grasa Grease	Aceite Oil			
380	600	148	12	3185	5586	841.50	990	165	23080 EKW33	AOH 3080
	600	200	12	4214	7840	688.50	810	220	24080 EK30W33	AOH 24080
	650	200	12	4557	7497	726.75	855	290	23180 EKW33	AOH 3180
	650	250	12	6076	10388	612.00	720	365	24180 EK30W33	AOH 24180
	720	256	12	6419	10192	512.55	603	470	23280 EKW33	AOH 3280
	820	243	12	7350	10192	573.75	675	675	22380 EKW33	AOH 3280
400	620	150	12	3332	5880	841.50	990	175	23084 EKW33	AOH 3084
	620	200	12	4312	8134	688.50	810	230	24084 EK30W33	AOH 24084
	700	224	12	5488	9114	688.50	810	375	23184 EKW33	AOH 3184
	700	280	12	7203	12348	535.50	630	470	24184 EK30W33	AOH 24184
	760	272	12	7203	11368	481.95	567	550	23284 EKW33	AOH 3284
420	650	157	12	3577	6419	765.00	900	200	23088 EKW33	AOHX 3088
	650	212	12	4704	8967	650.25	765	275	24088 EK30W33	AOH 24088
	720	226	12	5880	9800	650.25	765	380	23188 EKW33	AOHX 3188
	720	280	12	7350	12936	535.50	630	490	24188 EK30W33	AOH 24188
	790	280	12	7644	12250	459.00	540	620	23288 EKW33	AOHX 3288
440	680	163	12	3822	6811	726.75	855	225	23092 EKW33	AOHX 3092
	680	218	12	5096	9800	612.00	720	300	24092 EK30W33	AOH 24092
	760	240	12	6272	10584	612.00	720	465	23192 EKW33	AOHX 3192
	760	300	12	8134	14308	512.55	603	590	24192 EK30W33	AOH 24192
	830	296	12	8330	13426	428.40	504	725	23292 EKW33	AOHX 3292
460	700	165	12	3822	6664	726.75	855	235	23096 EKW33	AOHX 3096
	700	218	12	5194	10192	573.75	675	310	24096 EK30W33	AOH 24096
	790	248	12	6811	11760	573.75	675	515	23196 EKW33	AOHX 3196
	790	308	12	8820	15288	481.95	567	635	24196 EK30W33	AOH 24196
	870	310	12	9114	14700	405.45	477	860	23296 EKW33	AOHX 3296
480	720	167	12	4067	7644	688.50	810	250	230/500 EKW33	AOHX 30/500
	720	218	12	5390	10780	535.50	630	325	240/500 EK30W33	AOH 240/500
	830	264	12	7497	12642	535.50	630	610	231/500 EKW33	AOHX 31/500
	830	325	12	9604	16660	459.00	540	735	241/500 EK30W33	AOH 241/500
	920	336	12	10388	16954	382.50	450	1020	232/500 EKW33	AOHX 32/500
500	780	185	12	4998	9114	612.00	720	365	230/530 EKW33	AOH 30/530
	780	250	12	6566	12936	512.55	603	455	240/530 EK30W33	AOH 240/530
	870	272	12	7987	13720	512.55	603	720	231/530 EKW33	AOH 31/530
	870	335	12	10388	18620	428.40	504	885	241/530 EK30W33	AOH 241/530
	980	355	12	10878	19992	367.20	432	1290	232/530 EKW33	AOH 32/530
530	820	195	12	4480	9180	540	675	430	230/560 EKW33	AOH 30/560
	820	258	12	5880	13140	453.6	567	515	240/560 EK30W33	AOH 240/560
	920	280	12	7320	14400	453.6	567	850	231/560 EKW33	AOH 31/560
	920	355	12	9600	19440	360	450	1060	241/560 EK30W33	AOH 241/560
	1030	365	12	9200	19800	309.6	387	1500	232/560 EKW33	AOH 32/560
570	870	200	12	4800	10260	504	630	480	230/600 EKW33	AOH 30/600
	870	272	12	6520	15300	403.2	504	600	240/600 EK30W33	AOH 240/600
	980	300	12	8160	16200	403.2	504	1010	231/600 EKW33	AOH 31/600

RODAMIENTOS DE RODILLOS A RÓTULA SOBRE MANGUITO DE DESMONTAJE
SELF-ALIGNING ROLLER BEARINGS WITH WITHDRAWAL SLEEVE

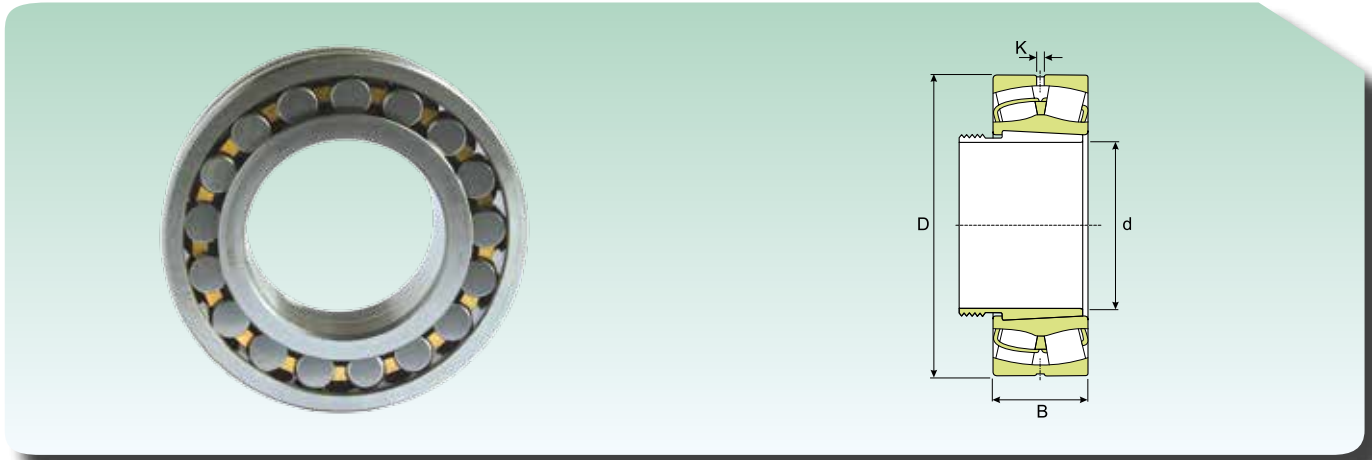

Dimensiones (mm) Dimension (mm)				Coeficiente de carga (KN) Load rating (KN)		Velocidad límite (rpm) Speed limit (Rpm)		Peso (Kg) Weight (Kg)	Sigla Designation	
d (mm)	D (mm)	B (mm)	K (mm)	Dinámico Dynamic C	Estático Static C ₀	Lubrificación Lubrication			Rodamiento Bearing	Manguito de desmontaje Withdrawal sleeve
						Grasa Grease	Aceite Oil			
	980	375	12	9200	21240	345.6	432	1290	241/600 EK30W33	AOH 241/600
	1090	388	12	10480	22950	288	360	1760	232/600 EKW33	AOH 32/600
600	920	212	12	5360	11250	482.4	603	575	230/630 EKW33	AOH 30/630
	920	290	12	7040	16200	381.6	477	730	240/630 EK30W33	AOH 240/630
	1030	315	12	8400	18720	381.6	477	1190	231/630 EKW33	AOH 31/630
	1030	400	12	10160	24300	324	405	1500	241/630 EK30W33	AOH 241/630
630	980	230	12	6120	13140	432	540	720	230/670 EKW33	AOH 30/670
	980	308	12	8000	18360	360	450	900	240/670 EK30W33	AOH 240/670
	1030	315	12	8400	18720	381.6	477	1430	231/670 EKW33	AOH 31/670
	1090	412	12	11040	26100	288	360	1730	241/670 EK30W33	AOH 241/670
	1220	438	12	12320	27450	259.2	324	2500	232/670 EKW33	AOH 32/670
670	1030	236	12	6640	14670	403.2	504	800	230/710 EKW33	AOH 30/710
	1030	315	12	8480	20520	324	405	1010	240/710 EK30W33	AOH 240/710
	1150	345	12	9760	23400	324	405	1650	231/710 EKW33	AOH 31/710
	1150	438	12	12160	29250	273.6	342	2040	241/710 EK30W33	AOH 241/710
	1280	450	12	14080	31050	230.4	288	2810	232/710 EKW33	AOH 32/710
710	1090	250	12	7720	16740	381.6	477	950	230/750 EKW33	AOH 30/750
	1090	335	12	9440	22500	309.6	387	1200	240/750 EK30W33	AOH 240/750
	1220	365	12	11040	26100	309.6	387	1930	231/750 EKW33	AOH 31/750
	1220	475	12	13840	33750	259.2	324	2280	241/750 EK30W33	AOH 241/750
	1360	475	12	14960	32850	216	270	3280	232/750 EKW33	AOH 32/750
750	1150	258	12	8000	18000	345.6	432	1100	230/800 EKW33	AOH 30/800
	1150	345	12	10320	25650	288	360	1380	240/800 EK30W33	AOH 240/800
	1280	375	12	11840	28350	288	360	2200	231/800 EK30W33	AOH 31/800
	1280	475	12	14720	36450	230.4	288	2540	241/800 EKW33	AOH 241/800
800	1220	272	12	7496	19440	324	405	1250	230/850 EKW33	AOH 30/850
	1220	365	12	10160	28350	259.2	324	1670	240/850 EK30W33	AOH 240/850
	1360	400	12	12880	31050	259.2	324	2500	231/850 EKW33	AOH 31/850
	1360	500	12	16160	40500	216	270	3050	241/850 EK30W33	AOH 241/850
850	1280	280	12	8080	20880	288	360	1450	230/900 EKW33	AOH 30/900
	1280	375	12	10880	31050	244.8	306	1850	240/900 EK30W33	AOH 240/900
	1420	515	12	17120	44100	201.6	252	3700	241/900 EK30W33	AOH 241/900
900	1360	300	12	9600	25650	273.6	342	1720	230/950 EKW33	AOH 30/950
	1360	412	12	11840	35100	216	270	2300	240/950 EK30W33	AOH 240/950
	1500	545	12	19120	49500	187.2	234	3950	241/950 EK30W33	AOH 241/950
950	1420	308	12	10160	27450	259.2	324	1900	230/1000 EKW33	AOH 30/1000
	1420	412	12	12320	36450	201.6	252	2500	240/1000 EK30W33	AOH 240/1000
	1580	462	12	17120	43200	201.6	252	3950	231/1000 EKW33	AOH 31/1000
	1580	580	12	21360	55800	172.8	216	4800	241/1000 EK30W33	AOH 241/1000
1000	1500	325	12	11040	30600	230.4	288	2600	230/1060 EKW33	AOH 30/1060
	1500	438	12	13840	40950	187.2	234	2950	240/1060 EK30W33	AOH 240/1060





Rodamientos axiales de bolas

Thrust ball bearings



RODAMIENTOS AXIALES DE BOLAS

- Rodamientos axiales de bolas de simple efecto.
- Rodamientos axiales de bolas de simple efecto, con arandela exterior esférica.
- Rodamientos axiales de bolas de doble efecto.
- Rodamientos axiales de bolas de doble efecto, con arandela exterior esférica.

RODAMIENTOS AXIALES DE BOLAS DE SIMPLE EFECTO

Los rodamientos **ISB**[®] axiales de bolas han sido diseñados para soportar cargas que actúan en una sola dirección y fijar el eje por uno de sus lados; no son idóneos para soportar cargas de tipo radial (**Fig. 1**). Este tipo específico de rodamiento está compuesto por una arandela para eje con un camino de rodadura constituido por una ranura, una jaula con bolas y una arandela para alojamiento (o exterior) también ésta con un camino de rodadura constituido por una ranura. Esta última arandela puede tener la superficie de asiento plana o esférica, según las exigencias. Los componentes se pueden aplicar por separado, ya que los rodamientos son desarmables y su montaje es simple.

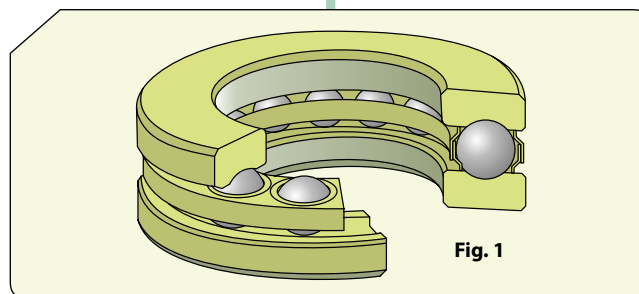

Fig. 1

RODAMIENTOS AXIALES DE BOLAS DE DOBLE EFECTO

Estos rodamientos pueden soportar cargas axiales en ambos sentidos y por tanto pueden servir para fijar un eje axialmente y no pueden soportar cargas radiales. Están constituidos por una arandela para eje, dos arandelas de alojamiento y dos grupos de jaulas con bolas (**Fig. 2**). Son además desarmables y fáciles de desmontar/montar.

Los rodamientos **ISB**[®] axiales de bolas de doble efecto pueden compensar desalineaciones axiales mediante la utilización de placas orientables no suministradas con el rodamiento.

Las arandelas para el alojamiento y los grupos jaula-bola son los mismos utilizados para los rodamientos de simple efecto.

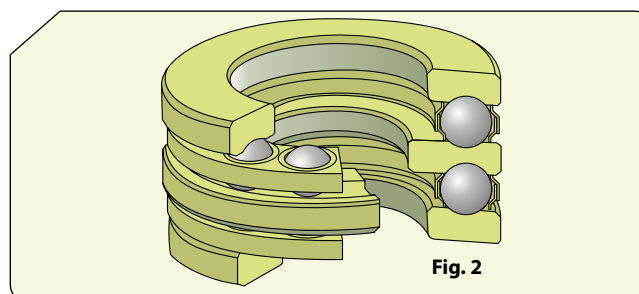

Fig. 2

THRUST BALL BEARINGS

- *Single direction thrust ball bearings.*
- *Single direction thrust ball bearings with outer spherical washer.*
- *Double direction thrust ball bearings.*
- *Double direction thrust ball bearings with outer spherical washer.*

SINGLE DIRECTION THRUST BALL BEARINGS

ISB[®] single direction thrust ball bearings are manufactured to withstand loads acting in just one direction and to bind the shaft on one side. They are not suitable to withstand radial loads (**Fig. 1**). This specific type of bearing consists of shaft washer with grooved raceway, a cage complete with balls and a housing washer (or outer washer) again with a grooved raceway. This last washer may have a flat or spherical support surface based on specific requirements. The components can be applied separately because the bearings are separable and easy to assemble.

DOUBLE DIRECTION THRUST BALL BEARINGS

This specific type of bearing is able to withstand loads acting on both sides, consequently they are able to bind the shaft on both sides. Likewise for the single direction thrust ball bearings, they cannot withstand radial loads. **ISB**[®] double direction thrust ball bearings consist of a housing washer (or outer washer) with groove. These last two washers may have a flat or spherical support surface based on specific requirements (**Fig. 2**). This type of bearing can compensate an initial misalignment using self-aligning plates, again with spherical surfaces. The double direction bearings are also separable and the housing washers and the cage-ball assemblies are the same as the corresponding single direction bearings.

DIMENSIONES

Las dimensiones generales de los rodamientos **ISB**® axiales de bolas respetan la norma ISO 104:2002.

Los rodamientos con arandelas para alojamiento con superficie de asiento esféricas tienen dimensiones según DIN 711 y DIN 715, cuando éstas resultan aplicables.

DESALINEACIÓN

Los rodamientos **ISB**® axiales de bolas con arandelas de alojamiento planas no permiten ninguna desalineación entre el eje y el alojamiento. Además tampoco permiten ninguna desalineación angular entre las superficies de apoyo en el alojamiento y en el eje. Los rodamientos con arandelas de alojamiento esféricas suelen utilizarse con arandelas de asiento esféricas y pueden compensar la desalineación inicial entre las superficies de apoyo en el alojamiento y en el eje. Los rodamientos con arandelas de alojamiento esféricas suelen utilizarse con arandelas de asiento esféricas y pueden compensar la desalineación inicial entre las superficies de apoyo en el alojamiento y en el eje (**Fig. 3**).

DIMENSIONS

The overall dimensions of **ISB**® thrust ball bearings comply with standard ISO 104:2002.

The dimensions of the bearings with housing washers with spherical support surfaces comply with DIN 711 and DIN 715, when applicable.

MISALIGNMENT

ISB® thrust ball bearings with flat housing washers cannot take any misalignment between the shaft and the housing. Furthermore, they cannot take any angular misalignments between the support surfaces in the housing and the shaft. The type of bearing with spherical housing washers is used together with washers for spherical seats and is able to compensate initial misalignments between the support surfaces in the housing and on the shaft. The type of bearing with washers for spherical housing is used together with washers for spherical seats and is able to compensate initial misalignments between the support surfaces in the housing and on the shaft (**Fig. 3**).

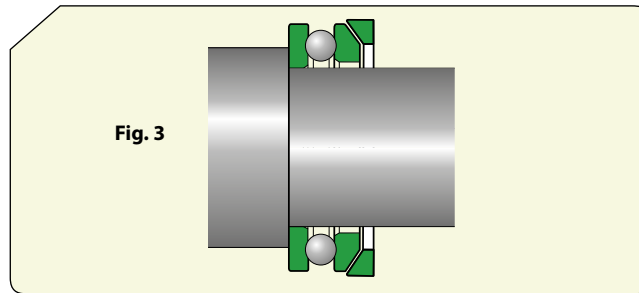

TOLERANCIAS

Los rodamientos **ISB**® axiales de bolas generalmente se fabrican con tolerancias normales. La serie 511 tiene clase de precisión más elevada, según P5 y P6. Contactar con nuestra oficina técnica de las aplicaciones.

TOLERANCES

ISB® thrust ball bearings are usually manufactured with Normal tolerances. Series 511 is manufactured with higher precision, according to P5 and P6. Contact our applications engineering department.

JAULAS

Los rodamientos **ISB**® axiales de bolas, en base a las dimensiones y a las series, se suministran con las siguientes jaulas:

- jaula moldeada de chapa de acero (**Fig. 4a**);
- jaula monobloque, mecanizada de latón (**Fig. 4b**);

CAGES

ISB® thrust ball bearings, based on the size and series, are supplied with the following cages:

- Pressed steel cage (**Fig. 4a**);
- Solid single-piece machined brass cage (**Fig. 4b**).

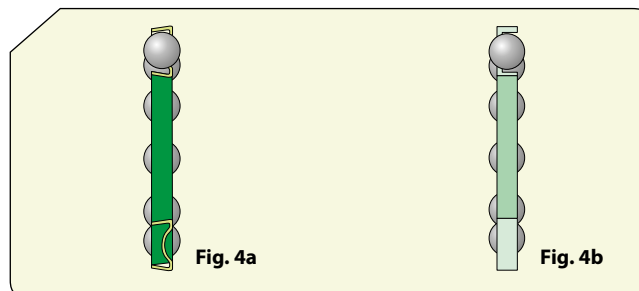

CARGA MÍNIMA

Los rodamientos **ISB**® axiales de bolas están sujetos a una cierta carga mínima sobre todo si giran a velocidades elevadas. En caso de utilización a altas velocidades y repentinos cambios de dirección, las fuerzas de inercia de las bolas y jaulas y la fricción del lubricante, pueden influir negativamente provocando deslizamientos.

MINIMUM LOAD

ISB® thrust ball bearings must always be subjected to a given minimum load, especially if they work at high speeds. In the case of high speeds and rapid changes in direction, the forces of inertia of the balls and cages and the friction of the lubricant may have a detrimental effect and cause contacts.

DESIGNACIONES SUPLEMENTARIAS

- F** Jaula mecanizada de acero, centrada en las bolas
- M** Jaula mecanizada de latón, centrada en las bolas.
- P5** Mayor precisión dimensional y de rotación, de conformidad con la clase de tolerancia 5 de la norma ISO
- P6** Mayor precisión dimensional y de rotación, de conformidad con la clase de tolerancia 6 de la norma ISO
- TN9** Jaula moldeada por inyección de poliamida 6.6 reforzada con fibras de vidrio, centrada en las bolas

SUPPLEMENTARY DESIGNATIONS

- F** *Solid machined steel cage, centred on the balls*
- M** *Solid machined brass cage, centred on the balls*
- P5** *Greater dimensional and rotation precision, compliant with tolerance class 5 of ISO standard*
- P6** *Greater dimensional and rotation precision, compliant with tolerance class 6 of ISO standard*
- TN9** *Injection moulded cage made of polyamide 6.6 with fibreglass reinforcement, centred on the balls*

RODAMIENTOS AXIALES DE BOLAS DE SIMPLE EFECTO SINGLE ACTING THRUST BALL BEARINGS

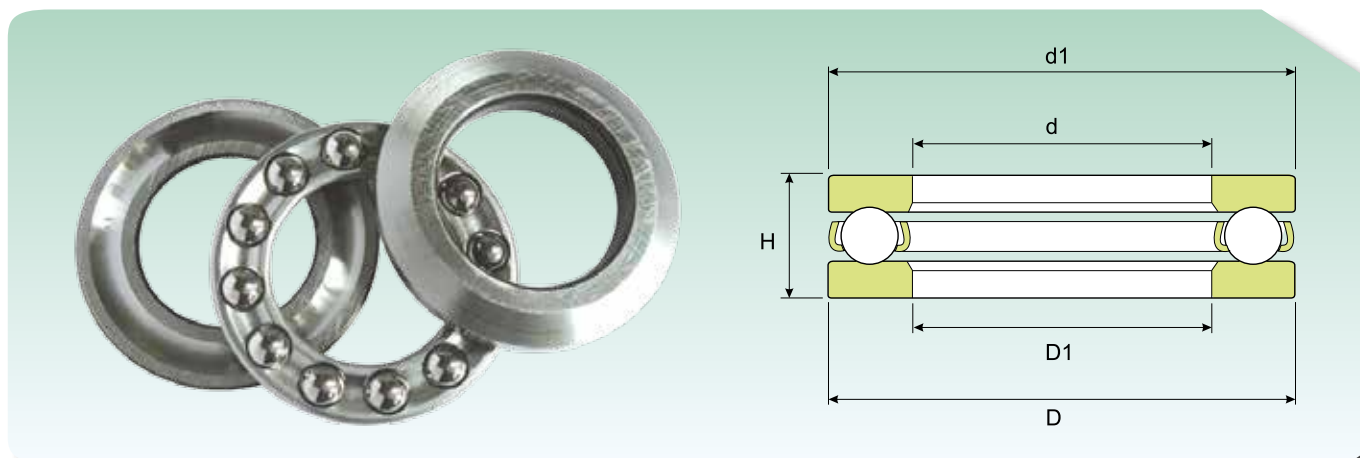

Dimensiones (mm) Dimension (mm)					Coeficiente de carga (KN) Load rating (KN)		Velocidad límite (rpm) Speed limit (Rpm)		Peso (Kg) Weight (Kg)	Sigla Designation
d (mm)	D (mm)	H (mm)	d1 (mm)	D1 (mm)	Dinámico Dynamic C	Estático Static C ₀	Lubrificación Lubrication			
							Grasa Grease	Aceite Oil		
3	8	3.5	7.8	3.2	0.79	0.71	27540	32400	0.0009	BA 3
4	10	4	9.8	4.2	0.75	0.71	22950	27000	0.0015	BA 4
5	12	4	11.8	5.2	0.83	0.95	21420	25200	0.0021	BA 5
6	14	5	13.8	6.2	1.74	1.88	18360	21600	0.0035	BA 6
7	17	6	16.8	7.2	2.46	2.84	14535	17100	0.0065	BA 7
8	19	7	18.8	8.2	3.13	3.72	13005	15300	0.0091	BA 8
9	20	7	19.8	9.2	3.06	3.72	12240	14400	0.01	BA 9
10	24	9	24	11	9.75	14.99	9945	11700	0.02	51100
	26	11	26	12	12.45	18.23	8415	9900	0.03	51200
12	26	9	26	13	10.19	16.27	9945	11700	0.022	51101
	28	11	28	14	13.03	20.38	8415	9900	0.034	51201
15	28	9	28	16	10.39	17.93	9180	10800	0.024	51102
	32	12	32	17	16.17	26.46	7650	9000	0.045	51202
17	30	9	30	18	11.17	20.78	9180	10800	0.026	51103
	35	12	35	19	16.86	29.40	7268	8550	0.053	51203
20	35	10	35	21	14.80	28.42	7650	9000	0.039	51104
	40	14	40	22	22.05	39.69	6120	7200	0.082	51204
25	42	11	42	26	18	38	6885	8100	0.06	51105
	47	15	47	27	27	54	5738	6750	0.11	51205
	52	18	52	27	34	59	4820	5670	0.12	51305
	60	24	60	27	54	95	3825	4500	0.34	51405
30	47	11	47	32	19	42	6503	7650	0.069	51106
	52	16	52	32	25	50	5126	6030	0.13	51206
	60	21	60	32	37	70	4055	4770	0.26	51306
	70	28	70	32	71	134	3290	3870	0.52	51406
35	52	12	52	37	20	50	5738	6750	0.08	51107
	62	18	62	37	34	72	4284	5040	0.22	51207
	68	24	68	37	48	95	3443	4050	0.39	51307
	80	32	80	37	85	167	2907	3420	0.74	51407
40	60	13	60	42	25	62	5355	6300	0.12	51108
	68	19	68	42	46	104	4055	4770	0.27	51208
	78	26	78	42	61	120	3290	3870	0.53	51308
	90	36	90	42	110	220	2601	3060	1.1	51408
45	65	14	65	47	26	68	4820	5670	0.15	51109
	73	20	73	47	38	85	3825	4500	0.32	51209
	85	28	85	47	75	150	3060	3600	0.66	51309
	100	39	100	47	127	260	2295	2700	1.42	51409

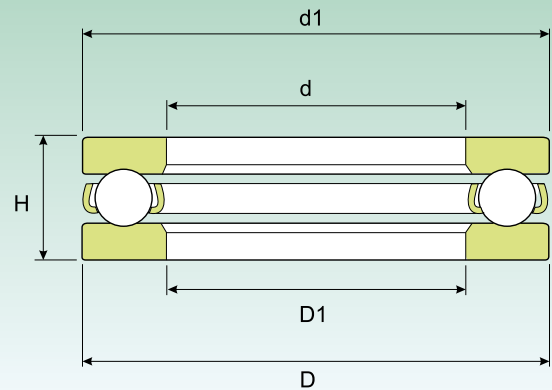
**RODAMIENTOS AXIALES DE BOLAS DE SIMPLE EFECTO
SINGLE ACTING THRUST BALL BEARINGS**

Dimensiones (mm) Dimension (mm)					Coeficiente de carga (KN) Load rating (KN)		Velocidad límite (rpm) Speed limit (Rpm)		Peso (Kg) Weight (Kg)	Sigla Designation
d (mm)	D (mm)	H (mm)	d1 (mm)	D1 (mm)	Dinámico Dynamic C	Estático Static C ₀	Lubrificación Lubrication			
							Grasa Grease	Aceite Oil		
50	70	14	70	52	26	74	4820	5670	0.16	51110
	78	22	78	52	48	114	3443	4050	0.37	51210
	95	31	85	52	87	186	2754	3240	0.94	51310
	110	43	100	52	156	333	2142	2520	2	51410
55	78	16	78	57	30	83	4055	4770	0.24	51111
	90	25	90	57	61	143	3060	3600	0.59	51211
	105	35	105	57	102	220	2448	2880	1.3	51311
	120	48	120	57	174	382	1836	2160	2.55	51411
60	85	17	85	62	41	120	3825	4500	0.3	51112
	95	26	95	62	61	147	2907	3420	0.65	51212
	110	35	110	62	99	220	2295	2700	1.35	51312
	130	51	130	62	195	421	1683	1980	3.1	51412 M
65	90	18	90	67	37	106	3672	4320	0.33	51113
	100	27	100	67	62	160	2754	3240	0.78	51213
	115	36	115	67	104	235	2295	2700	1.5	51313
	140	56	140	68	212	480	1683	1980	4	51413 M
70	95	18	95	72	39	118	3443	4050	0.35	51114
	105	27	105	72	64	170	2754	3240	0.79	51214
	125	40	125	72	132	314	1989	2340	2	51314
	150	60	150	73	229	539	1530	1800	5	51414 M
75	100	19	100	77	43	143	3290	3870	0.4	51115
	110	27	110	77	66	179	2601	3060	0.83	51215
	135	44	135	77	160	382	1836	2160	2.6	51315
	160	65	160	78	246	598	1377	1620	6.75	51415 M
80	105	19	105	82	44	150	3290	3870	0.42	51116
	115	28	115	82	75	204	2601	3060	0.91	51216
	140	44	140	82	156	382	1836	2160	2.7	51316
	170	68	170	83	265	657	1301	1530	7.95	51416 M
85	110	19	110	87	45	160	3290	3870	0.44	51117
	125	31	125	88	96	270	2295	2700	1.2	51217
	150	49	150	88	186	456	1683	1980	3.55	51317
	180	72	177	88	280	735	1224	1440	9.45	51417 M
90	120	22	120	92	58	204	2907	3420	0.65	51118
	135	35	135	93	117	319	2142	2520	1.7	51218
	155	50	155	93	191	490	1683	1980	3.8	51318
	190	77	187	93	301	799	1148	1350	11	51418 M
100	135	25	135	102	83	284	2448	2880	0.97	51120
	150	38	150	103	122	338	1836	2160	2.2	51220
	170	55	170	103	224	598	1454	1710	4.95	51320
	210	85	205	103	364	1039	1071	1260	15	51420 M

RODAMIENTOS AXIALES DE BOLAS DE SIMPLE EFECTO
SINGLE ACTING THRUST BALL BEARINGS

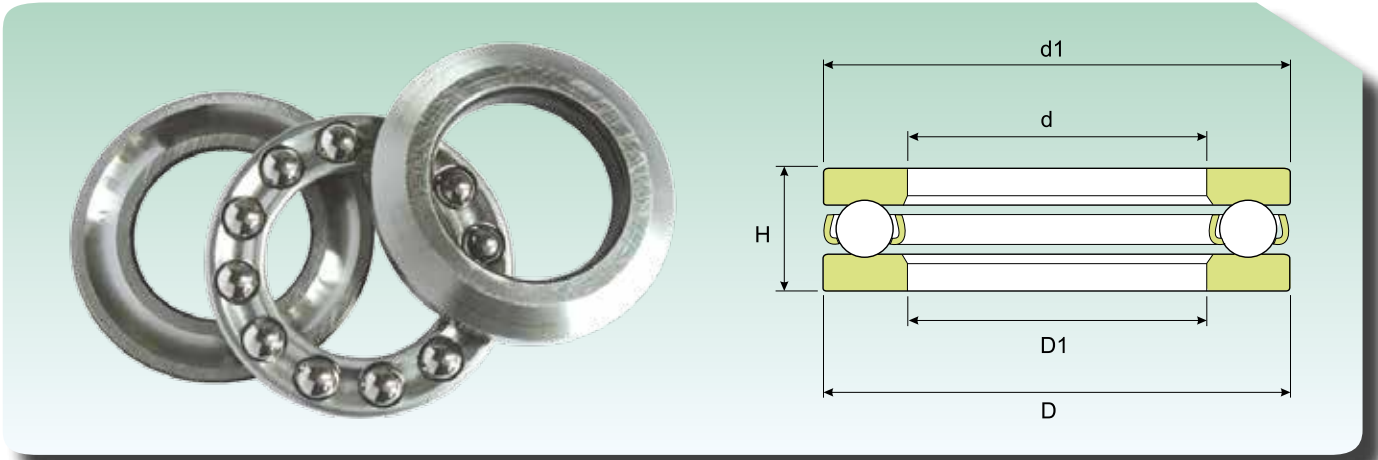

Dimensiones (mm) Dimension (mm)					Coeficiente de carga (KN) Load rating (KN)		Velocidad límite (rpm) Speed limit (Rpm)		Peso (Kg) Weight (Kg)	Sigla Designation
d (mm)	D (mm)	H (mm)	d1 (mm)	D1 (mm)	Dinámico Dynamic C	Estático Static C ₀	Lubrificación Lubrication			
							Grasa Grease	Aceite Oil		
110	145	25	145	112	85	309	2448	2880	1.05	51122
	160	38	160	113	127	382	1836	2160	2.4	51222
	190	63	187	113	275	799	1301	1530	7.85	51322 M
	230	95	225	113	402	1196	995	1170	20	51422 M
120	155	25	155	122	87	328	2295	2700	1.15	51124
	170	39	170	123	137	431	1683	1980	2.65	51224
	210	70	205	123	319	960	1148	1350	11	51324 M
	250	102	245	123	510	1695	842	990	29.5	51424 M
130	170	30	170	132	109	417	1989	2340	1.85	51126
	190	45	190	133	182	573	1530	1800	4	51226
	225	75	220	134	351	1117	1836	2160	13	51326 M
	270	110	265	134	510	1695	765	900	32	51426 M
140	180	31	178	142	109	431	1989	2340	2.05	51128
	200	46	197	143	186	608	1454	1710	4.35	51228
	240	80	235	144	389	1294	995	1170	15.5	51328 M
	280	112	275	144	510	1695	765	900	34.5	51428 M
150	190	31	188	152	109	431	1836	2160	2.2	51130 M
	215	50	212	153	233	784	1377	1620	6.1	51230 M
	250	80	245	154	402	1372	995	1170	16.5	51330 M
	300	120	295	154	548	1921	727	855	42.5	51430 M
160	200	31	198	162	110	456	1836	2160	2.35	51132 M
	225	51	222	163	237	833	1301	1530	6.55	51232 M
	270	87	265	164	440	1627	918	1080	21	51332 M
170	215	34	213	172	130	529	1683	1980	3.3	51134 M
	240	55	237	173	280	1000	1377	1620	8.15	51234 M
	280	87	275	174	459	1725	842	990	22	51334 M
180	225	34	222	183	132	559	1683	1980	3.5	51136 M
	250	56	245	183	290	1058	1148	1350	8.6	51236 M
	300	95	295	184	510	1960	842	990	28.5	51336 M
	360	140	360	184	761	2160			70.5	51436
190	240	37	237	193	169	696	1530	1800	4.05	51138 M
	270	62	265	194	325	1245	1071	1260	12	51238 M
	320	105	315	195	580	2352	727	855	36.5	51338 M
200	250	37	247	203	165	696	1454	1710	4.25	51140 M
	280	62	275	204	331	1294	1071	1260	12	51240 M
	340	110	335	205	612	2548	689	810	44.5	51340 M
220	270	37	267	223	174	784	1454	1710	4.6	51144 M
	300	63	295	224	344	1431	995	1170	13	51244 M
240	300	45	317	243	229	1019	1224	1440	7.55	51148 M
	340	78	355	244	453	1960	842	990	23	51248 M

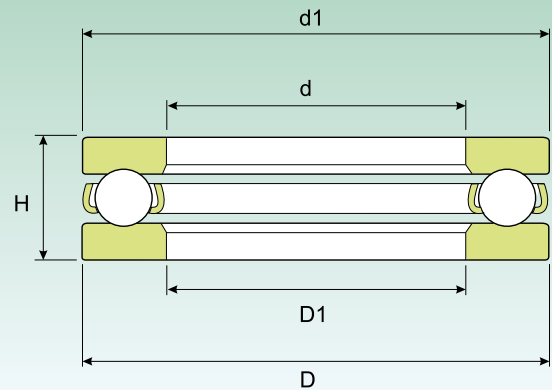
**RODAMIENTOS AXIALES DE BOLAS DE SIMPLE EFECTO
SINGLE ACTING THRUST BALL BEARINGS**

Dimensiones (mm) Dimension (mm)					Coeficiente de carga (KN) Load rating (KN)		Velocidad límite (rpm) Speed limit (Rpm)		Peso (Kg) Weight (Kg)	Sigla Designation
d (mm)	D (mm)	H (mm)	d1 (mm)	D1 (mm)	Dinámico Dynamic C	Estático Static C ₀	Lubrificación Lubrication			
							Grasa Grease	Aceite Oil		
260	320	45	317	263	233	1078	1148	1350	8.1	51152 M
	360	79	355	264	466	2117	842	990	25	51252 M
	480	175	480	268	1110	4000	-	-	135	51452
280	350	53	347	283	313	1431	995	1170	12	51156 M
	380	80	375	284	484	2274	765	900	26.5	51256 M
300	380	62	376	304	357	1725	842	990	17.5	51160 M
	420	95	415	304	593	2940	650	765	42	51260 M
320	400	63	396	324	364	1823	842	990	19	51164 M
	440	95	435	325	561	2940	612	720	45.5	51264 M
340	420	64	416	344	369	1921	842	990	20.5	51168 M
	460	96	455	345	593	3136	574	675	48.5	51268 M
	540	160	540	345	1040	4300	-	-	135	51368
360	440	65	436	364	382	2038	765	900	22	51172 M
	500	110	495	365	726	4067	536	630	70	51272 M
366	440	65	440	370	296	1080	-	-	19.5	BD1B 634132
380	460	36	460	385	186	830	-	-	12.5	351793
	460	65	456	384	389	2156	765	900	23	51176 M
	520	112	515	385	713	4067	536	630	73	51276 M
385	510	110	510	385	618	2500	-	-	66	350550
400	480	65	476	404	395	2234	765	900	24	51180 M
420	500	65	496	424	402	2352	765	900	25.5	51184 M
	580	130	580	426	884	4000	-	-	110	51284
440	520	65	520	445	302	1200	-	-	24	BD1B 634131
	540	80	536	444	516	3185	650	765	42	51188 M
	600	130	600	446	904	4150	-	-	115	51288
460	560	80	556	464	516	3185	612	720	43.5	51192 M
480	580	80	576	484	529	3479	612	720	45.5	51196 M
500	600	80	596	504	542	3528	612	720	47	511/500 M
530	590	36	590	535	178	1000	-	-	12.5	351794
	640	85	636	534	637	4312	675	540	58.5	511/530 M
545	635	65	635	545	251	1020	-	-	33.5	BD1B634141
560	670	67	670	564	475	2400	-	-	45.5	591/560
	670	85	666	564	650	4557	630	504	61	511/560 M
600	710	67	710	604	475	2500	-	-	45.5	591/600
	710	85	706	604	650	4704	630	504	65	511/600 M
	740	90	740	605	637	3400	-	-	84.5	350534
	800	90	800	610	676	3650	-	-	117	350769

RODAMIENTOS AXIALES DE BOLAS DE SIMPLE EFECTO
SINGLE ACTING THRUST BALL BEARINGS

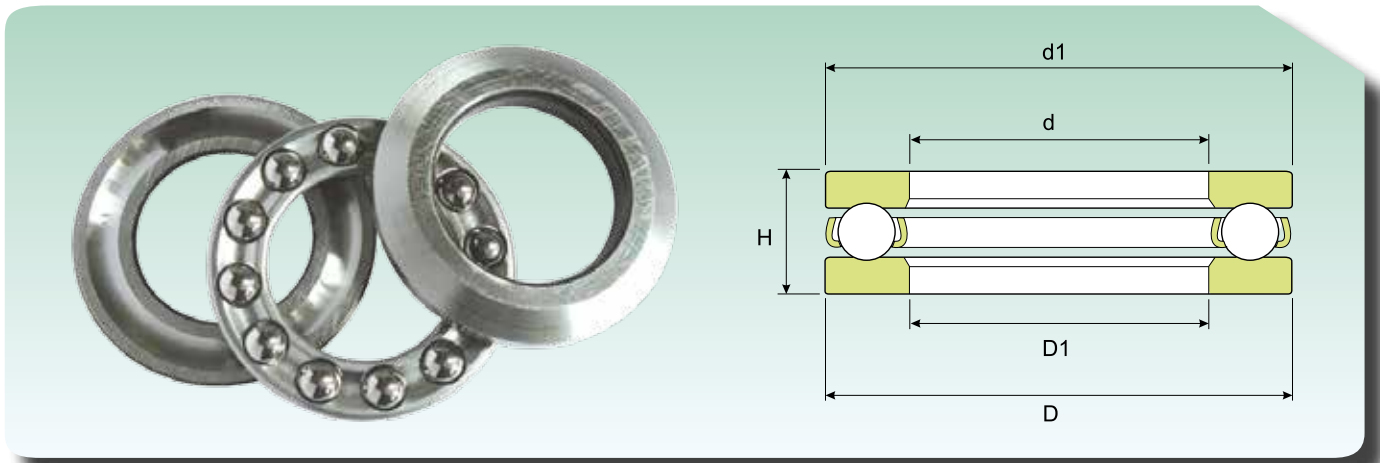

Dimensiones (mm) Dimension (mm)					Coeficiente de carga (KN) Load rating (KN)		Velocidad límite (rpm) Speed limit (Rpm)		Peso (Kg) Weight (Kg)	Sigla Designation
d (mm)	D (mm)	H (mm)	d1 (mm)	D1 (mm)	Dinámico Dynamic C	Estático Static C ₀	Lubrificación Lubrication			
							Grasa Grease	Aceite Oil		
630	750	95	746	634	714	5292	567	454	84	511/630 M
640	700	55	700	642	168	980	-	-	25	350015
670	800	78	800	675	540	3050	-	-	74	591/670
	800	105	795	675	835	6566	504	403	105	511/670 M
730	850	85	850	730	663	4000	-	-	88	350627 A
750	900	90	900	755	741	4500	-	-	105	591/750
	900	120	900	755	1010	6300	-	-	150	511/750
800	950	90	950	805	761	4800	-	-	110	591/800/351589 A
850	1000	90	1000	855	761	5000	-	-	115	591/850
950	1120	103	1120	956	852	6000	-	-	170	591/950
980	1120	120	1120	985	1010	7350	-	-	170	BD1B 351883
1000	1180	109	1180	1006	936	6700	-	-	200	591/1000/351395
1250	1500	150	1500	1258	1430	11800	-	-	510	351006 A
1380	1540	130	1540	1385	1330	11800	-	-	310	BD1B 351890 A
1400	1630	180	1630	1408	1900	17300	-	-	610	511/1400
1420	1620	100	1620	1420	1040	8800	-	-	320	351346 B
1800	1950	120	1950	1805	1110	11200	-	-	350	510/1800

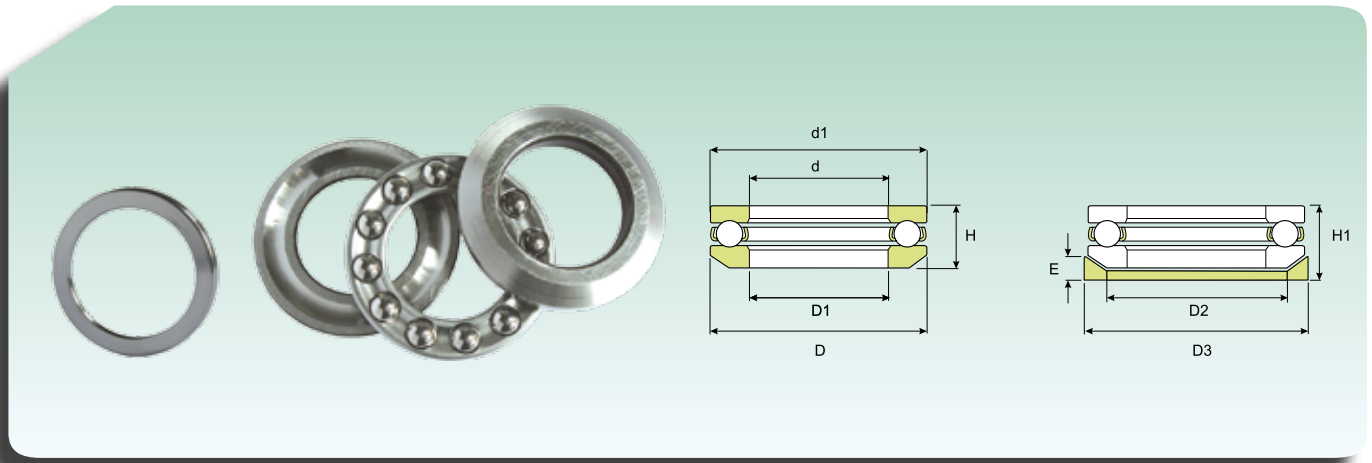
RODAMIENTOS AXIALES DE BOLAS DE SIMPLE EFECTO, CON ARANDELA ESFÉRICA
SINGLE ACTING THRUST BALL BEARINGS WITH OUTER SPHERICAL RING

Dimensiones (mm) Dimension (mm)									Coeficiente de carga (kN) Load rating (kN)		Velocidad límite (rpm) Speed limit (Rpm)		Peso Rodamiento con arandela (Kg) Weight Bearing with ring(Kg)	Sigla Designation	
d (mm)	D (mm)	H1 (mm)	d1 (mm)	D1 (mm)	D2 (mm)	D3 (mm)	H (mm)	E (mm)	Dinámico Dynamic C	Estático Static C ₀	Lubrificación Lubrication			Rodamiento Bearing	Arandela Ring
		Grasa Grease		Aceite Oil											
12	28	13	28	14	20	30	11.4	3.5	13	20	8415	9900	0.045	53201	U 201
15	32	15	32	17	24	35	13.3	4	16	26	7650	9000	0.063	53202	U 202
17	35	15	35	19	26	38	13.2	4	17	29	7268	8550	0.071	53203	U 203
20	40	17	40	20	30	42	14.73	5	22	40	6120	7200	0.1	53204	U 204
25	47	19	47	27	36	50	16.72	5.5	27	54	5738	6750	0.15	53205	U 205
30	52	20	52	32	42	55	17.8	5.5	25	50	5126	6030	0.18	53206	U 206
	60	25	60	32	45	62	22.6	7	37	70	4055	4770	0.33	53306	U 306
35	62	22	62	37	48	65	19.87	7.5	34	72	4284	5040	0.28	53207	U 207
	68	28	68	37	52	72	25.6	7	48	95	3443	4050	0.46	53307	U 307
40	68	23	68	42	50	72	20.3	7	46	104	4055	4770	0.35	53208	U 208
	78	31	78	42	60	82	28.5	8.5	61	120	3290	3870	0.67	53308	U 308
	90	42	90	42	65	95	38.2	12	110	220	2601	3060	1.35	53408	U 408
45	73	24	73	47	60	78	21.3	7.5	38	85	3825	4500	0.39	53209	U 209
	85	33	85	47	65	90	30.13	10	75	150	3060	3600	0.83	53309	U 309
50	78	26	78	52	62	82	23.49	7.5	48	114	3443	4050	0.47	53210	U 210
	95	37	95	52	72	100	34.3	11	87	186	2754	3240	1.2	53310	U 310
	110	50	110	52	80	115	45.6	14	156	333	2142	2520	2.31	53410	U 410
55	90	30	90	57	72	95	27.35	9	61	143	3060	3600	0.75	53211	U 211
	105	42	105	57	80	110	39.3	11.5	102	220	2448	2880	1.68	53311	U 311
	120	55	120	57	88	125	50.5	15.5	174	382	1836	2160	3.08	53411	U 411
60	95	31	95	62	78	100	28.02	9	61	147	2907	3420	0.82	53212	U 212
	110	42	110	62	85	115	38.3	11.5	99	220	2295	2700	1.71	53312	U 312
	130	58	130	62	95	135	54	16	195	421	1683	1980	3.8	53412 M	U 412
65	100	32	100	67	82	105	28.7	9	62	160	2754	3240	0.91	53213	U 213
	115	43	115	67	90	120	39.4	12.5	104	235	2295	2700	1.89	53313	U 313
70	105	32	105	72	88	110	28.8	9	64	170	2754	3240	0.97	53214	U 214
	125	48	125	72	98	130	44.2	13	132	314	1989	2340	2.5	53314	U 314
	150	69	150	73	110	155	63.6	19.5	229	539	1530	1800	6.5	53414 M	U 414
75	110	32	110	77	92	115	28.3	9.5	66	179	2601	3060	1	53215	U 215
	135	52	135	77	105	140	48.1	15	160	382	1836	2160	3.2	53315	U 315
	160	75	160	78	115	165	69	21	246	598	1377	1620	8.1	53415 M	U 415
80	115	33	115	82	98	120	29.5	10	75	204	2601	3060	1.1	53216	U 216
	140	52	140	82	110	145	47.6	15	156	382	1836	2160	3.3	53316	U 316
85	125	37	125	88	105	130	33.1	11	96	270	2295	2700	1.5	53217	U 217
	150	58	150	88	115	155	53.1	17.5	186	456	1683	1980	4.35	53317	U 317

RODAMIENTOS AXIALES DE BOLAS DE SIMPLE EFECTO, CON ARANDELA ESFÉRICA
SINGLE ACTING THRUST BALL BEARINGS WITH OUTER SPHERICAL RING

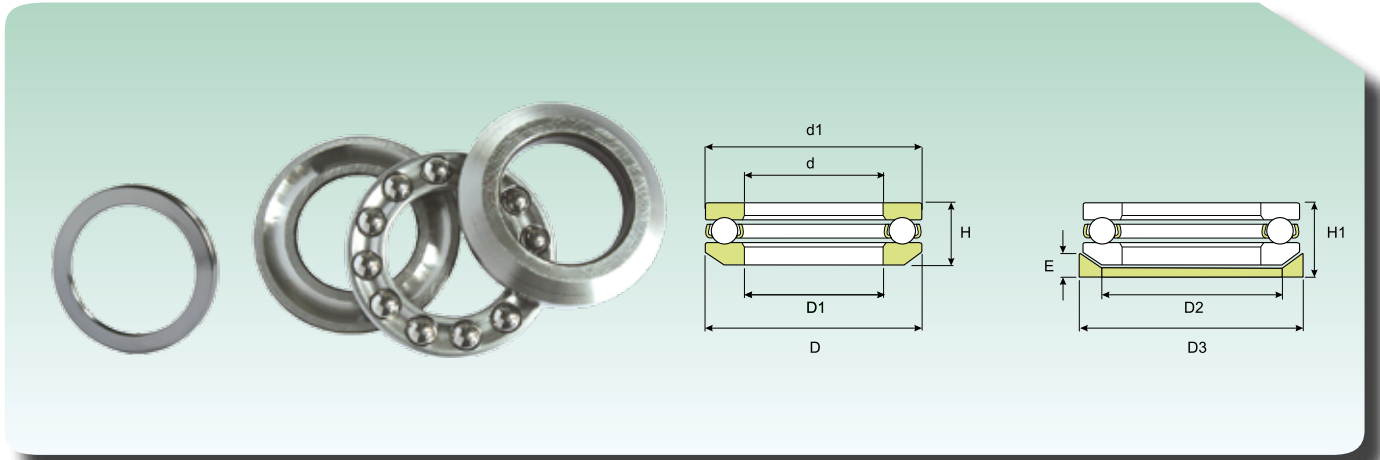

Dimensiones (mm) Dimension (mm)									Coeficiente de carga (KN) Load rating (KN)		Velocidad límite (rpm) Speed limit (Rpm)		Peso Rodamiento con arandela (Kg) Weight Bearing with ring(Kg)	Sigla Designation	
d (mm)	D (mm)	H1 (mm)	d1 (mm)	D1 (mm)	D2 (mm)	D3 (mm)	H (mm)	E (mm)	Dinámico Dynamic C	Estático Static C ₀	Lubricación Lubrication			Rodamiento Bearing	Arandela Ring
											Grasa Grease	Aceite Oil			
90	135	42	135	93	110	140	38.5	13.5	117	319	2142	2520	2.1	53218	U 218
	155	59	155	93	120	160	54.6	18	191	490	1683	1980	4.7	53318	U 318
	190	88	187	93	140	195	81.2	25.5	301	799	1148	1350	13	53418 M	U 418
100	150	45	150	103	125	155	40.9	14	122	338	1836	2160	2.7	53220	U 220
	170	64	170	103	135	175	59.2	18	224	598	1454	1710	5.95	53320	U 320
	210	98	205	103	155	220	90	27	364	1039	1071	1260	18	53420 M	U420
110	160	45	160	113	135	165	40.2	14	127	382	1836	2160	2.91	53222	U 222
	190	72	187	113	150	195	67.5	20.5	275	799	1301	1530	9.1	53322 M	U 322
120	170	46	170	123	145	175	40.8	15	137	431	1683	1980	3.2	53224	U 224
	210	80	205	123	165	220	74.1	22	319	960	1148	1350	12.5	53324 M	U 324
130	190	53	187	133	160	195	47.9	17	182	573	1530	1800	4.85	53226	U 226
140	200	55	197	143	170	210	48.6	17	186	608	1454	1710	5.45	53228	U 228

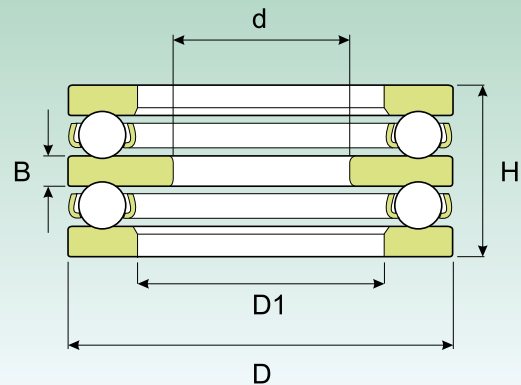
**RODAMIENTOS AXIALES DE BOLAS DE DOBLE EFECTO
DOUBLE ACTING THRUST BALL BEARINGS**

Dimensiones (mm) Dimension (mm)					Coeficiente de carga (KN) Load rating (KN)		Velocidad límite (rpm) Speed limit (Rpm)		Peso (Kg) Weight (Kg)	Sigla Designation
d (mm)	D (mm)	H (mm)	D1 (mm)	B (mm)	Dinámico Dynamic C	Estático Static C ₀	Lubrificación Lubrication			
							Grasa Grease	Aceite Oil		
10	32	22	17	5	16	26	7650	9000	0.084	52202
15	40	26	22	6	22	40	6120	7200	0.15	52204
20	47	28	27	7	27	54	5738	6750	0.22	52205
	52	34	27	8	34	59	4820	5670	0.33	52305
	70	52	32	12	72	134	3825	4500	1	52407
25	52	29	32	7	25	50	5126	6030	0.25	52206
	60	38	32	9	37	70	4055	4770	0.45	52306
	80	59	37	15	86	167	3290	3780	1.45	52406
30	62	34	37	8	34	72	4284	5040	0.41	52207
	68	36	42	9	46	104	4055	4770	0.55	52208
	68	44	37	10	48	95	3443	4050	0.68	52307
	78	49	42	12	61	120	3290	3870	1.05	52308
	90	65	42	15	110	220	2550	3050	2.05	52408
35	73	37	47	9	38	85	3825	4500	0.6	52209
	85	52	47	12	75	150	3060	3600	1.24	52309
	100	72	47	17	127	260	2907	2700	2.70	52409
40	78	39	52	9	48	114	3443	4050	0.67	52210
	95	58	52	14	87	186	2754	3240	1.75	52310
45	90	45	57	10	61	143	3060	3600	1.1	52211
	105	64	57	15	102	220	2448	2880	2.4	52311
	120	87	57	20	172	382	1836	2160	4.70	52411
50	95	46	62	10	61	147	2907	3420	1.16	52212
	110	64	62	15	99	220	2295	2700	2.55	52312
	130	93	62	21	195	421	1700	1980	6.35	52412 M
55	100	47	67	10	62	160	2754	3240	1.35	52213
	105	47	72	10	63	169	2754	3240	1.50	52214
	115	65	67	15	104	235	2295	2700	2.75	52313
	125	72	72	16	132	314	1989	2340	3.65	52314
	150	107	73	24	229	539	1530	1800	9.70	52414 M
60	110	47	77	10	66	179	2601	3060	1.55	52215
	135	79	77	18	160	382	1836	2160	4.8	52315
65	115	48	82	10	75	204	2601	3060	1.7	52216
	140	79	82	18	156	382	1836	2160	4.94	52316
70	125	55	88	12	96	270	2295	2700	2.4	52217
75	135	62	93	14	117	319	2142	2520	3.2	52218
85	150	67	103	15	122	338	1836	2160	4.2	52220
	170	97	103	21	225	598	1400	1710	8.95	52320
95	160	67	113	15	127	382	1836	2160	4.65	52222
100	170	68	123	15	137	431	1683	1980	5.25	52224

RODAMIENTOS AXIALES DE BOLAS DE DOBLE EFECTO
DOUBLE ACTING THRUST BALL BEARINGS

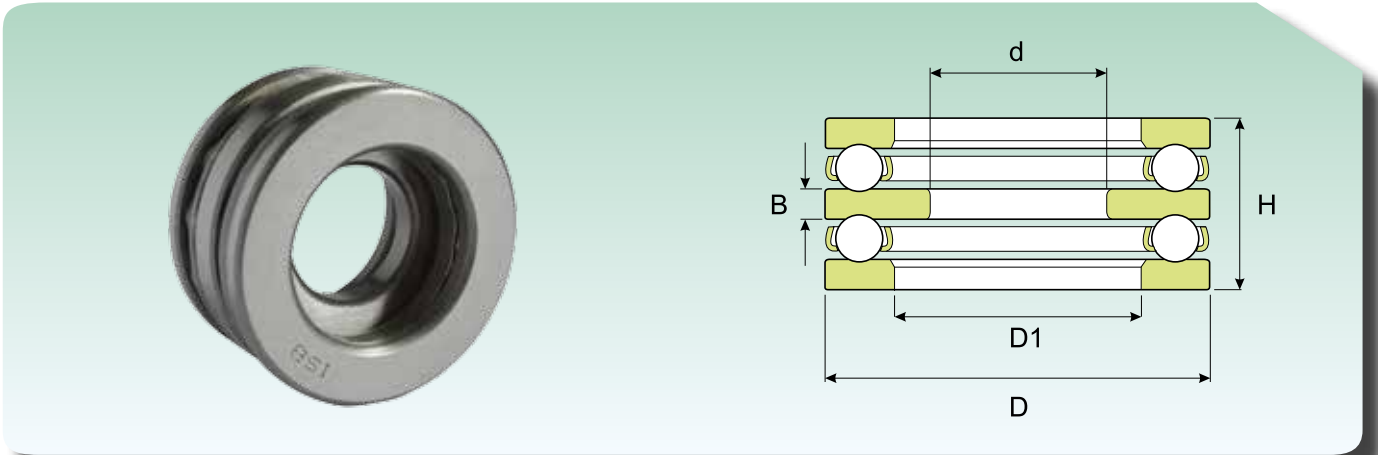

Dimensiones (mm) Dimension (mm)					Coeficiente de carga (KN) Load rating (KN)		Velocidad límite (rpm) Speed limit (Rpm)		Peso (Kg) Weight (Kg)	Sigla Designation
d (mm)	D (mm)	H (mm)	D1 (mm)	B (mm)	Dinámico Dynamic C	Estático Static C ₀	Lubrificación Lubrication			
							Grasa Grease	Aceite Oil		
110	190	80	133	18	182	573	1530	1800	8	52226
120	200	81	143	18	186	608	1454	1710	8.65	52228
130	215	89	153	20	233	784	1377	1620	11.5	52230 M
140	225	90	163	20	236	833	1530	1300	12	52232 M
150	240	97	173	21	281	999	1224	1440	15	52234 M
	250	98	183	21	290	1000	1150	1350	16	52236 M

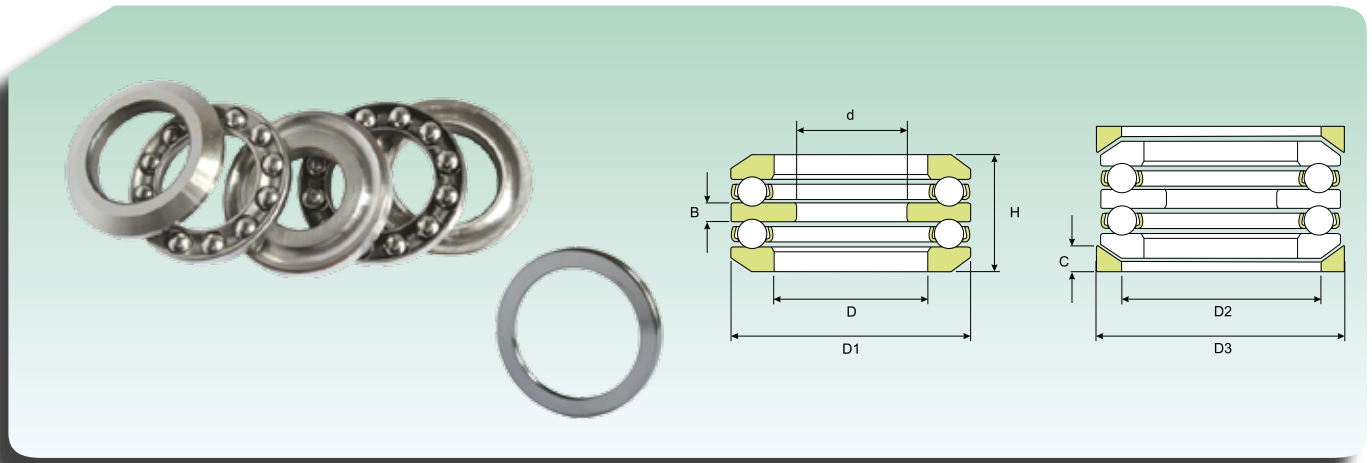
**RODAMIENTOS AXIALES DE BOLAS DE DOBLE EFECTO, CON ARANDELAS PARA ALOJAMIENTO ESFÉRICAS
DOUBLE DIRECTION THRUST BALL BEARINGS WITH SPHERICAL BACK FACE**

Dimensiones (mm) Dimension (mm)									Coeficiente de carga (KN) Load rating (KN)		Velocidad límite (rpm) Speed limit (Rpm)		Peso Rodamiento con arandela (Kg) Weight Bearing with ring(Kg)	Sigla Designation	
d (mm)	D (mm)	H1 (mm)	D1 (mm)	D2 (mm)	D3 (mm)	H (mm)	B (mm)	C (mm)	Dinámico Dynamic C	Estático Static C ₀	Lubrificación Lubrication			Rodamiento Bearing	Arandela Ring
											Grasa Grease	Aceite Oil			
25	60	46	32	45	62	41.3	9	7	36.946	69.58	3816	4770	0.58	54306	U 306
30	62	42	37	48	65	37.73	8	7	34.398	72.03	4032	5040	0.53	54207	U 207
	68	44	42	55	72	38.6	9	7	45.864	103.88	3816	4770	0.63	54208	U 208
	68	52	37	52	72	47.19	10	7.5	48.412	94.57	3240	4050	0.85	54307	U 307
	78	59	42	60	82	54.1	12	8.5	60.564	119.56	3096	3870	1.17	54308	U 308
35	73	45	47	60	78	39.6	9	7.5	38.22	84.77	3600	4500	0.78	54209	U 209
	85	62	47	65	90	56.2	12	10	74.578	152.88	2880	3600	1.6	54309	U 309
	100	86	47	72	105	78.9	17	12.5	127.4	259.7	2160	2700	3	54409	U 409
40	95	70	52	72	100	64.7	14	11	86.632	186.2	2592	3240	2.3	54310	U 310
	100	92	52	80	115	83.2	18	14	155.82	333.2	2016	2520	4.45	54410	U 410
45	90	55	57	72	95	49.6	10	9	60.564	143.08	2880	3600	1.3	54211	U 211
50	110	78	62	85	115	70.7	15	11.5	98.98	219.52	2160	2700	2.9	54312	U 312
65	140	95	82	110	145	86.1	18	18	155.82	382.2	1728	2160	0.57	54316	U 316
	170	140	83	125	175	128.5	27	22	264.6	656.6	1224	1530	1.4	54416 M	U 416
70	150	105	88	115	155	95.2	19	17.5	186.2	455.7	1584	1980	7.95	54317	U 317
80	210	176	103	155	220	159.9	33	27	363.58	1038.8	1008	1260	29	54420 M	U 420



Rodamientos axiales de contacto angular de bolas, de doble efecto, de alta precisión

Angular contact thrust ball bearing, double direction, high-precision



RODAMIENTOS AXIALES DE BOLAS CON CONTACTO ANGULAR, DE DOBLE EFECTO, DE ALTA PRECISIÓN

Este tipo de rodamiento ha sido realizado principalmente para los mandriles de las máquinas herramientas, que deben satisfacer prestaciones exigentes en lo que respecta a la velocidad de rotación y precisión de montaje (Fig.1).

ANGULAR CONTACT THRUST BALL BEARING, DOUBLE DIRECTION, HIGH-PRECISION

This type of bearing is manufactured mainly for spindles of machine tools, which must satisfy uprated performance requirements in terms of rotation speed and assembly precision (Fig.1).

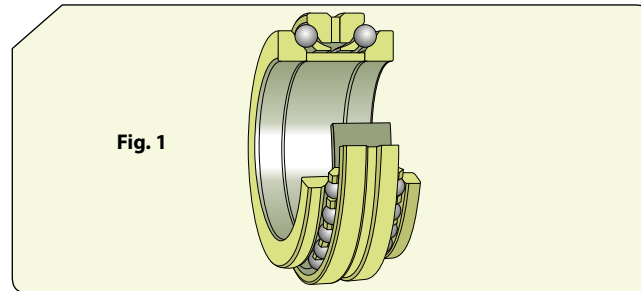

Este tipo de rodamiento, axial de bolas con contacto angular de doble efecto, ha sido proyectado para su utilización junto con los rodamientos de dos hileras de rodillos cilíndricos de la serie NN30..., con diámetros interiores y exteriores idóneos para su combinación. Los diámetros exteriores de los rodamientos se ofrecen con diversas soluciones de tolerancia, para poder así garantizar distintas soluciones de combinación. Estos rodamientos son desarmables.

En la arandela de alojamiento está prevista una ranura en la circunferencia exterior, con tres agujeros, para permitir una eficaz lubricación.

DIMENSIONES

Las dimensiones de los diámetros, interior y exterior, de los rodamientos axiales de bolas con contacto angular de doble efecto, están estandarizadas de conformidad con las normas ISO 15-1981; no están estandarizados en cambio los restantes valores, ya que deben satisfacer exigencias constructivas de los diversos sectores de aplicación.

DESALINEACIÓN

Los rodamientos axiales de bolas con contacto angular de doble efecto no soportan ninguna desalineación entre la arandela del eje y la arandela del alojamiento. No se toleran tampoco errores de cuadratura entre el eje y la superficie de apoyo de la arandela exterior.

JAULAS

Los rodamientos axiales de bolas de contacto angular de doble efecto, cuentan con dos jaulas mecanizadas de latón guiadas sobre las bolas.

This type of double direction angular contact thrust ball bearing is designed for use in combination with double row cylindrical ball bearings of series NN30..., with inside and outside diameters suitable for being paired. The outside diameters of the bearings are fulfilled with different tolerance solutions to be able to ensure various solutions of combinations. These bearings are separable.

In the housing washer, there is a groove on the outer circumference with three holes to ensure efficient lubrication.

DIMENSIONS

The dimensions of the inside and outside diameters of the double direction angular contact thrust ball bearings are standard and compliant with standards ISO 15-1981; all the other parameters however are not standard because they must satisfy special constructional requirements of the different fields of applications.

DISPLACEMENT

The double direction angular contact thrust ball bearings do not withstand any displacement between the shaft washer and the housing washer. Squaring errors are also not tolerated between the shaft axle and the contact surface of the outer washer.

CAGES

The double direction angular contact thrust ball bearings have two solid brass cages guided on the balls.

RODAMIENTOS AXIALES DE BOLAS CON CONTACTO ANGULAR, DE DOBLE EFECTO, DE ALTA PRECISI3N
ANGULAR CONTACT THRUST BALL BEARING, DOUBLE DIRECTION, HIGH-PRECISION

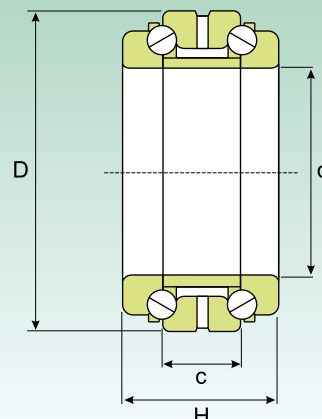

Dimensiones (mm) Dimension (mm)				Coeficiente de carga (KN) Load rating (KN)		Velocidad l3mite (rpm) Speed limit (Rpm)		Peso (Kg) Weight (Kg)	Sigla Designation
d (mm)	D (mm)	H (mm)	c (mm)	Dinámico Dynamic C	Estático Static C ₀	Lubrificaci3n Lubrication			
						Grasa Grease	Aceite Oil		
50	80	38	19	30	75	8245	9700	0,62	234410
	72	28	14	20	55	-	-	0,75	234910
75	115	48	24	45	140	5820	6790	1,55	234415
	105	38	19	25	100	-	-	1,30	234915
80	125	54	27	52	175	5141	6111	2,10	234416
	110	38	19	35	140	-	-	1,90	234916
85	130	54	27	50	180	5141	6111	2,20	234417
	150	54	22	35	140	-	-	1,90	234917
90	140	60	30	60	215	4656	5432	3,00	234418
	125	44	22	48	170	-	-	2,50	234918
95	145	60	30	70	220	4656	5432	3,05	234419
	130	44	22	58	182	-	-	2,75	234919
100	150	60	30	46,4	180	290	380	3,13	234420
	140	48	24	40	160	-	-	2,80	234920
105	160	66	33	84	250	4171	4850	4,15	234421
	145	48	24	70	195	260	350	3,50	234921
110	170	72	36	90	320	3880	4656	4,60	234422
	150	48	24	79	275	-	-	3,85	234922
120	180	72	36	107	360	3686	4365	5,54	234424
	165	54	27	89	290	-	-	5,00	234924
130	200	84	42	115	445	3298	3880	7,90	234426
	180	60	30	100	380	-	-	6,30	234926
140	210	84	42	114	470	3104	3686	8,65	234428
	190	60	30	110	395	-	-	7,30	234928
150	225	90	45	192	390	2910	3492	12,50	234430
	210	72	36	116	320	-	-	7,260	234930
160	240	96	48	185	680	190	250	14,00	234432
	220	72	36	105	550	-	-	12,50	234932
170	260	108	54	221	750	2328	2910	18,50	234434
	230	72	36	182	600	-	-	16,00	234934
180	280	120	60	220	896	1940	2522	23,00	234436
	250	84	42	180	635	-	-	21,50	234936
190	290	120	60	220	931	1940	2522	24,00	234438
	260	84	42	180	610	-	-	22,00	234938
200	310	132	66	259	1078	1843	2328	31,00	234440
	280	96	48	230	850	-	-	27,00	234940
	340	144	72	230	900	-	-	40,50	234444

RODAMIENTOS AXIALES DE BOLAS CON CONTACTO ANGULAR, DE DOBLE EFECTO, DE ALTA PRECISIÓN
ANGULAR CONTACT THRUST BALL BEARING, DOUBLE DIRECTION, HIGH-PRECISION

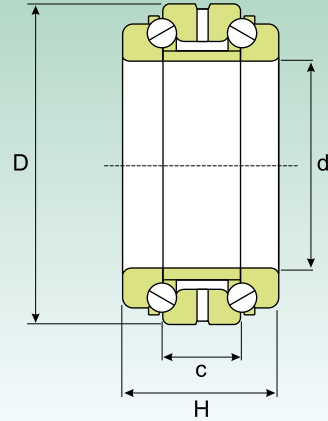

Dimensiones (mm) Dimension (mm)				Coeficiente de carga (KN) Load rating (KN)		Velocidad límite (rpm) Speed limit (Rpm)		Peso (Kg) Weight (Kg)	Sigla Designation
d (mm)	D (mm)	H (mm)	c (mm)	Dinámico Dynamic C	Estático Static C ₀	Lubrificación Lubrication			
						Grasa Grease	Aceite Oil		
220	300	96	48	300	900	-	-	-	234944
	360	144	72	340	1330	-	-	-	234448
240	320	96	48	350	1420	-	-	-	234948
	420	164	82	380	1500	-	-	-	234456
280	380	120	60	415	1790	-	-	-	234956
300	460	190	95	480	2170	-	-	-	234460
	420	144	72	450	1950	-	-	-	234960



Rodamientos axiales de rodillos a rótula

Self-aligning thrust roller bearings



RODAMIENTOS AXIALES DE RODILLOS A RÓTULA

Los rodamientos **ISB**[®] axiales de rodillos a rótula (**Fig. 1**) están compuestos en modo tal que la carga se transmita de un camino de rodadura a otro, siguiendo un cierto ángulo respecto al eje del rodamiento.

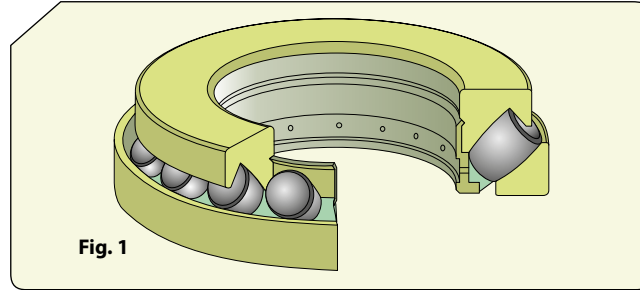

Esta característica permite a dichos rodamientos soportar cargas axiales y contemporaneamente cargas radiales (**Fig. 2**). Su autoalineación los hace insensibles a las inflexiones del eje y a las desalineaciones de éste último respecto al alojamiento. Los rodamientos **ISB**[®] axiales de rodillos a rótula son idóneos para soportar cargas axiales muy elevadas y altas velocidades de servicio. Están provistos de muchos rodillos asimétricos y el diseño de los caminos de rodadura permite un óptimo contacto.

SPHERICAL ROLLER THRUST BEARINGS

ISB[®] spherical roller thrust bearings (**Fig. 1**) are designed in such a way that the load is transmitted from one raceway to the other at a certain angle compared to the bearing's axis.

(**Fig. 2**) This features means that these bearings are able to withstand axial loads acting simultaneously with radial loads. They are self-aligning and consequently insensitive to shaft deflections and shaft misalignments compared to the housing. **ISB**[®] spherical roller thrust bearings are able to withstand very high axial loads and high operating speeds. They have a large number of asymmetric rollers and the special design of the raceways enables optimum conformity.

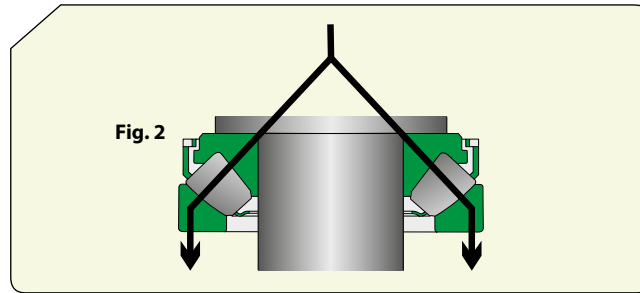

DIMENSIONES

Las dimensiones generales de los rodamientos **ISB**[®] axiales de rodillos a rótula respetan la norma ISO 104:2002.

TOLERANCIAS

Los rodamientos **ISB**[®] axiales de rodillos a rótula generalmente se fabrican con tolerancias normales, como se indica en la norma ISO 199:1997.

DESALINEACIÓN

Siendo autoalineables, toleran la desalineación del eje respecto al alojamiento y las inflexiones del eje mismo (**Fig. 3**). La posibilidad de aprovechar al máximo esta desalineación dependerá del tipo de rodamiento y de la obturación.

DIMENSIONS

The overall dimensions of the **ISB**[®] spherical roller thrust bearings comply with standard ISO 104:2002.

TOLERANCES

ISB[®] spherical roller thrust bearings are usually manufactured with Normal tolerances, according to standard ISO 199:1997.

MISALIGNMENT

Seeing as they are self-aligning, the misalignment of the shaft compared to the housing and also shaft deflections are tolerated (**Fig. 3**). The possibility to fully exploit this misalignment depends on the type of bearing and the seal.

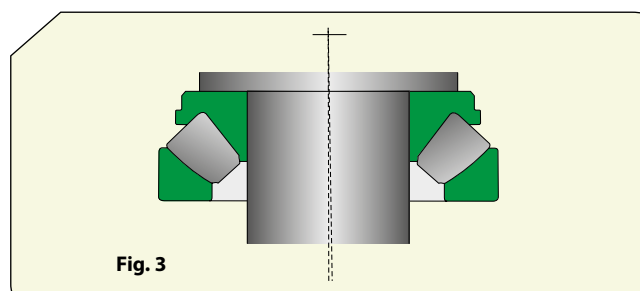

CARGA MÍNIMA

Los rodamientos **ISB**[®] axiales de rodillos a rótula están sujetos a una cierta carga mínima sobre todo si giran a velocidades elevadas. En caso de utilización a altas velocidades y repentinos cambios de dirección, las fuerzas de inercia de las bolas y las jaulas y la fricción del lubricante, pueden influir negativamente provocando deslizamientos entre los rodillos y los caminos de rodadura.

DESIGNACIONES SUPLEMENTARIAS

- E** Diseño interior optimizado y jaula moldeada en acero del tipo de ventana
- EF** Diseño interior optimizado y jaula mecanizada de acero
- EM** Diseño interior optimizado y jaula mecanizada de latón

MINIMUM LOAD

ISB[®] spherical roller thrust bearings must always be subjected to a given minimum load, especially if they work at high speeds. In the case of high speeds and rapid changes in direction, the forces of inertia of the balls and the cages and the friction of the lubricant may have a detrimental effect, causing harmful contact between the rollers and the raceways.

SUPPLEMENTARY DESIGNATIONS

- E** Optimised internal design and pressed window-type steel cage
- EF** Optimised internal design and solid machined steel cage
- EM** Optimised internal design and solid machined brass cage

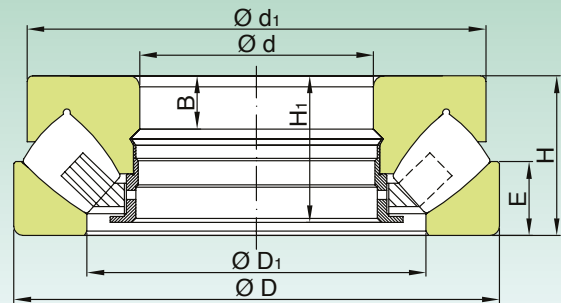
**RODAMIENTOS AXIALES DE RODILLOS A RÓTULA
SELF-ALIGNING THRUST ROLLER BEARINGS**

struttura fino a foro $\varnothing 100$
design up to bore $\varnothing 100$

Dimensiones (mm) Dimension (mm)								Coeficiente de carga (KN) Load rating (KN)		Velocidad límite (rpm) Speed limit (Rpm)		Peso (Kg) Weight (Kg)	Sigla Designation
d (mm)	D (mm)	H (mm)	D1 (mm)	B (mm)	H1 (mm)	E (mm)	d1 (mm)	Dinámico Dynamic C	Estático Static C ₀	Lubrificación Lubrication			
										Grasa Grease	Aceite Oil		
60	130	42	88	14.5	39	20	118	280	815	3825	2400	2.6	29412 M
65	140	45	96.5	16	42.1	21	128	330	965	3672	2200	3.3	29413 M
70	150	48	102	17	44.1	23	137	360	1060	3290	2000	4.0	29414 M
75	160	51	109	18	48.4	24	146	415	1250	3060	2000	4.87	29415 M
80	170	54	116	19	49.5	26	155	450	1370	2907	1900	5.8	29416 M
85	180	58	125.2	20	55.3	28	164	510	1560	2754	1800	6.90	29417 M
90	155	39	117	13	37.1	19	148.50	392	1058	3060	3600	2.85	29318 M
	190	60	130	21	55.2	29	174	570	1760	2601	1700	8.10	29418 M
100	170	42	127.5	34		20.6	158.9	456	1264	2754	3240	3.8	29320 M
	210	67	142	54		31.5	189	960	2450	2295	2700	10.6	29420 M
110	190	48	142	37.5		23	176	598	1695	2448	2880	5.6	29322 M
	230	73	155.5	58		34.4	208	1156	2940	2142	2520	16.5	29422 M
120	210	54	156	42		25.9	193.5	750	2078	2142	2520	7.45	29324 M
	250	78	172	62.4		38	220	1343	3381	1989	2340	17	29424 M
130	225	58	168	44		27.8	206.7	848	2450	1989	2340	9.3	29326 M
	270	85	185	63		41	248	1529	3969	1836	2160	22	29426 M
140	240	60	183	46		28	221	960	2793	1989	2340	10.7	29328 M
	280	85	197.5	64		42	252	1597	4214	1836	2160	24.6	29428 M
150	215	39	176	24		20.5	200.4	400	1568	2142	2520	4.3	29230 M
	250	60	190	47		29	228	980	2793	1836	2160	11.2	29330 M
	300	90	214	70		44	275	1823	4998	1683	1980	38.1	29430 M
160	270	67	205	53		31.7	249.6	1156	3381	1683	1980	14.5	29332 M
	320	95	220.5	73		46.4	290	2038	5488	1530	1800	34.5	29432 M
170	280	67	216	49.6		31.7	260.3	1176	3479	1683	1980	16	29334 M
	340	103	234	80		48.8	310	2313	6419	1454	1710	44	29434 M
180	250	42	208	31.8		21.8	237	485	1999	1989	2340	5.88	29236 M
	300	73	229	56		34.4	275	1401	4214	1530	1800	19.6	29336 M
	360	109	249.5	85		51.8	326	2548	7203	1377	1620	63.1	29436 M
190	320	78	240.5	59.5		38.6	298.3	1597	4655	1454	1710	24.5	29338 M
	380	115	263	89.5		54.2	345	2793	7840	1301	1530	60.8	29438 M
200	280	48	233.5	35.3		24.3	266	643	2597	1683	1980	8.9	29240 M
	340	85	259	64		39.1	314	1823	5390	1301	1530	30.3	29340 M
	400	122	278	95		57.5	363	3136	8820	1224	1440	69	29440 M
220	300	48	253	36.5		24.3	285	676	2940	1683	1980	9.45	29244 M
	360	85	277.5	64		40.7	336	1960	6174	1301	1530	33	29344 M
	420	122	298.5	95		57	383.8	3283	9457	1148	1350	73.9	29444 M

RODAMIENTOS AXIALES DE RODILLOS A RÓTULA
SELF-ALIGNING THRUST ROLLER BEARINGS

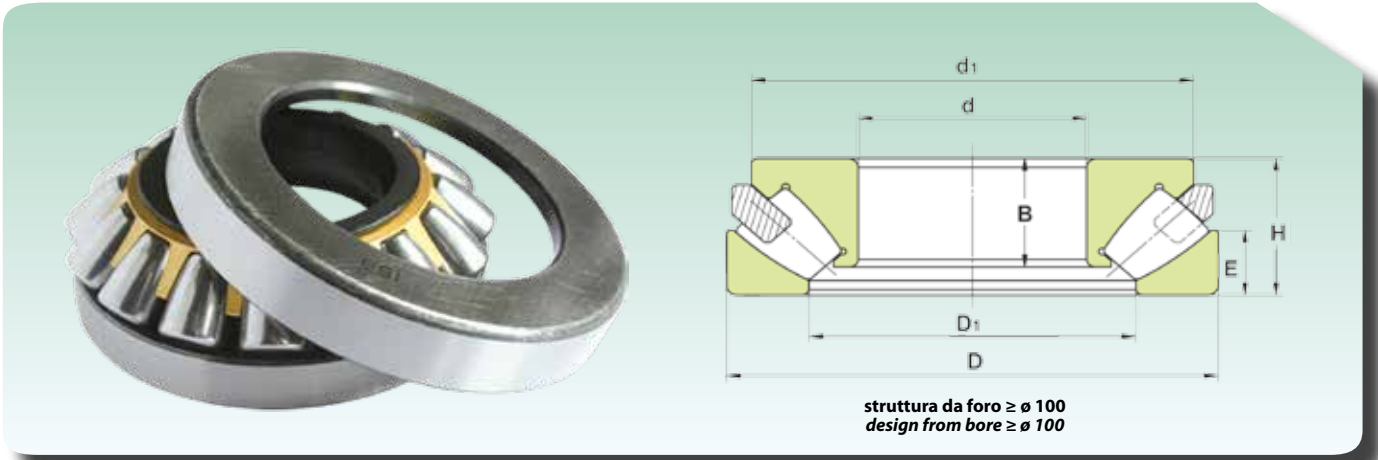

Dimensiones (mm) Dimension (mm)							Coeficiente de carga (KN) Load rating (KN)		Velocidad límite (rpm) Speed limit (Rpm)		Peso (Kg) Weight (Kg)	Sigla Designation
d (mm)	D (mm)	H (mm)	D1 (mm)	B (mm)	E (mm)	d1 (mm)	Dinámico Dynamic C	Estático Static C ₀	Lubrificación Lubrication			
									Grasa Grease	Aceite Oil		
240	340	60	281.5	46.4	29.6	324	783	3381	1377	1620	16.8	29248 M
	380	85	298.5	63	41.7	360	1999	6419	1224	1440	36	29348 M
	440	122	318.5	92.5	59.4	399	3332	9996	1148	1350	78	29448 M
260	360	60	302	46.2	29.8	343	801	3577	1301	1530	18	29252 M
	420	95	327.5	70	46	392.3	2499	8134	1071	1260	49.3	29352 M
	480	132	342	99	65	441	3969	12642	995	1170	102	29452 M
280	380	60	322.5	46.2	29.5	364	846	3920	1301	1530	21.9	29256 M
	440	95	346	70	46.3	411	2499	8477	1071	1260	50.3	29356 M
	520	145	373.5	109.5	69	472	4802	14994	918	1080	131	29456 M
300	420	73	350.5	53	35.8	398.9	1049	4704	1071	1260	29.3	29260 M
	480	109	371.5	83	53	448	3038	10388	918	1080	72.5	29360 M
	540	145	395	109.9	68.3	494.4	4224	16268	918	1080	138	29460 M
320	440	73	369.5	54	36	420	1088	4998	1071	1260	31.6	29264 M
	500	109	393	81.5	53	468	3283	10976	918	1080	75.4	29364 M
	580	155	420	116	75	534	4851	18620	842	990	174	29464 M
340	460	73	390	54	36	440	1107	5292	995	1170	33	29268 M
	540	122	428	40.6	117	59.5	2656	10780	842	990	105	29368 M
	620	170	449.5	128	80.1	560	5635	21952	765	900	211	29468 M
360	500	85	423	25	81	44	1431	6664	918	1080	52	29272 M
	560	122	442.5	90	58.1	523.3	2705	11368	842	990	111	29372 M
	640	170	470	126	81	588	5243	20776	727	855	224	29472 M
380	520	85	441	27	81	42	1548	7497	842	990	53	29276 M
	600	132	473	99.5	62.2	565	3273	13720	765	900	135	29376 M
	670	175	494	67	168	87.5	5753	23520	689	810	260	29476 M
400	540	85	460	62.5	42	514	1578	7840	842	990	61	29280 M
	620	132	489	100	64.7	582	3381	14308	727	855	154	29380 M
	710	185	529.5	138	86	652	6429	25970	650	765	298	29480 M
420	580	95	485	71	49.2	552.1	1950	9604	765	900	76	29284 M
	650	140	520	49	135	67.5	3665	15680	689	810	170	29384 M
	730	185	542.5	140	89.9	668	6595	26950	650	765	310	29484 M
440	600	95	508	30	91	46.5	2029	10192	765	900	78	29288 M
	680	145	540	49	140	70.5	4400	18914	650	765	180	29388 M
	780	206	583	150	97	716	7664	31360	574	675	407	29488 M
460	620	95	530	30	91	46	2029	10388	727	855	81	29292 M
	710	150	567	50	144	72.5	4224	18620	612	720	215	29392 M
	800	206	596	77	199	101.5	7830	32830	574	675	425	29492 M
480	650	103	556	33	99	53.5	2303	11564	689	810	98	29296 M
	730	150	582	112	74	684	4283	19208	612	720	212	29396 M
	850	224	625	88	216	108	9359	38220	513	603	550	29496 M

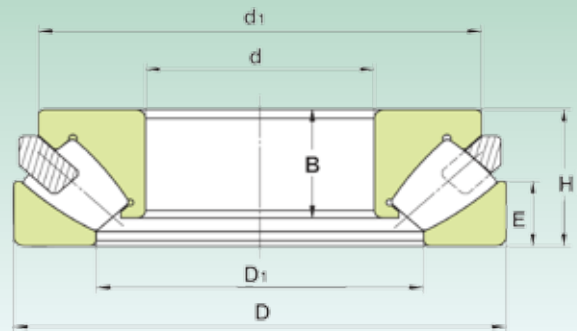
**RODAMIENTOS AXIALES DE RODILLOS A RÓTULA
SELF-ALIGNING THRUST ROLLER BEARINGS**

struttura da foro $\geq \varnothing 100$
design from bore $\geq \varnothing 100$

Dimensiones (mm) Dimension (mm)							Coeficiente de carga (KN) Load rating (KN)		Velocidad límite (rpm) Speed limit (Rpm)		Peso (Kg) Weight (Kg)	Sigla Designation
d (mm)	D (mm)	H (mm)	D1 (mm)	B (mm)	E (mm)	d1 (mm)	Dinámico Dynamic C	Estático Static C ₀	Lubrificación Lubrication			
									Grasa Grease	Aceite Oil		
500	670	103	571.5	76	50.5	640.5	2342	12250	689	810	97.5	292/500 M
	750	150	611	50	144	74	4400	19992	612	720	235	293/500 M
	870	224	650	160	107	797	9183	39200	513	603	555	294/500 M
530	710	109	604	80	56	675	3048	14994	650	765	118	292/530 M
	800	160	648	53	154	76	5125	23128	574	675	270	293/530 M
	920	236	686	89	228	116	10290	43120	482	567	650	294/530 M
560	750	115	644	37	111	61	2930	15680	612	720	140	292/560 M
	980	250	727	99	241	122	11760	49980	428	504	810	294/560 M
600	800	122	687	90	58.9	770	3665	18228	536	630	161	292/600 M
	900	180	720	65	174	89	7379	33810	482	567	405	293/600 M
	1030	258	770.5	185	126	954.8	12838	54880	405	477	860	294/600 M
630	850	132	723	50	127	62	4675	23128	513	603	210	292/630 M
	950	190	761	68	183	92	8281	37240	459	540	485	293/630 M
	1090	280	815	107	270	137	14112	60760	383	450	1040	294/630 M
670	900	140	773	45	135	73	4116	22344	482	567	255	292/670 M
	1150	290	872	205	138	1054	15092	66640	344	405	1225	294/670 M
710	1060	212	855	74	205	103	9751	44590	383	450	660	293/710 M
	1220	308	917	117	298	149	17248	74970	329	387	1500	294/710 M
750	1000	150	858	50	144	74	5978	30380	428	504	325	292/750 M
	1120	224	910	76	216	109	9183	44100	367	432	770	293/750 M
	1280	315	964	121	305	153	18326	83300	306	360	1650	294/750 M
800	1060	155	911	52	149	77	6429	33810	405	477	380	292/800 M
	1180	230	965	77	222	111	9751	48020	344	405	865	293/800 M
	1360	335	1034	123	324	165	19796	91140	275	324	2025	294/800 M
850	1120	160	967	47	154	82	6595	35280	383	450	425	292/850 M
	1440	354	1077	142	342	172	23422	105840	260	306	2390	294/850 M
900	1520	372	1137	147	360	186	26166	119560	230	270	2650	294/900 M
950	1250	180	1087	58	174	88	8114	44590	329	387	600	292/950 M
	1600	390	1209	153	377	191	27636	129360	214	252	3065	294/950 M
1000	1670	402	1270	155	389	190	30478	137200	199	234	3380	294/1000 M
1060	1400	206	1211	66	199	100	10290	57330	275	324	860	292/1060 M
	1770	426	1349	192	412	207	32732	152880	184	216	4280	294/1060 M
1180	1520	206	1331	83	199	101	10682	62720	260	306	950	292/1180 M
1250	1800	330	1474	148	319	161	24304	126420	184	216	2770	293/1250 M
1600	2280	408	1885	166	395	195	36064	196000	122	144	5375	293/1600 M



Rodamientos axiales de rodillos cónicos, de doble efecto

Tapered roller thrust bearings, double direction

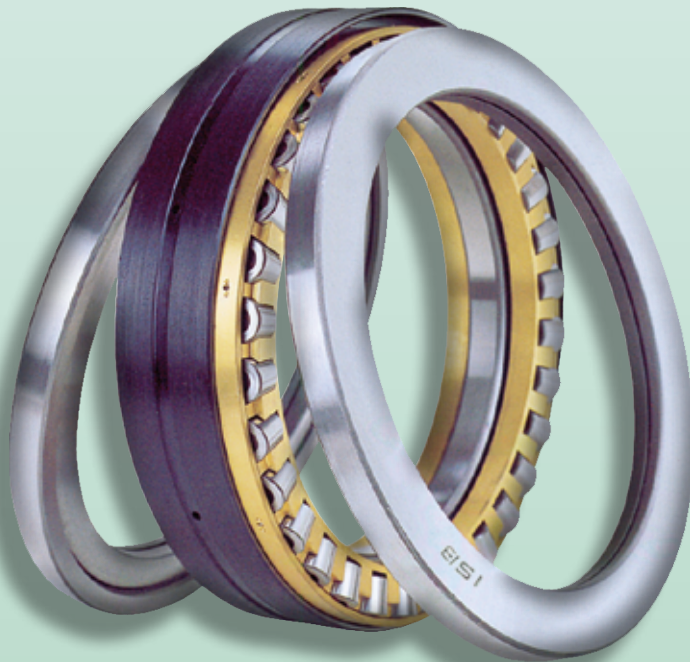

RODAMIENTOS AXIALES DE RODILLOS CÓNICOS DE DOBLE EFECTO

Los rodamientos axiales de rodillos cónicos de este tipo pueden soportar empujes axiales en las dos direcciones. No soportan las cargas radiales.

DOUBLE DIRECTION TAPERED ROLLER THRUST BEARINGS

This type of tapered roller thrust bearings can withstand axial loads in both directions. They are not able to withstand radial loads.

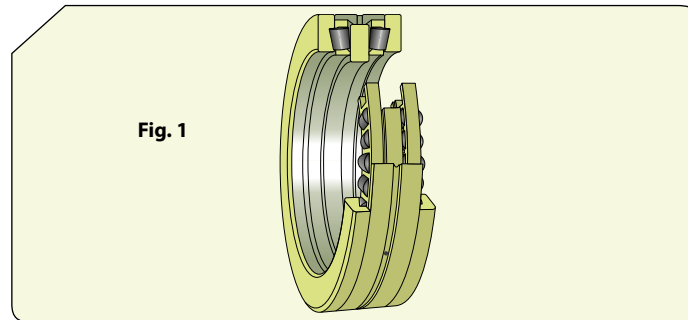

Las dos arandelas para alojamiento tienen caminos de rodadura cónicos y una pestaña de guía; la arandela para eje es plana. Esto significa que estos rodamientos pueden soportar una leve excentricidad del eje respecto al agujero del alojamiento.

Entre las dos arandelas para alojamiento está emplazado un distanciador, proporcionado para que, después del montaje, se logre un juego axial normal para estos rodamientos.

Con los rodamientos axiales de rodillos cónicos de doble efecto se podrán lograr prestaciones satisfactorias y una durabilidad adecuada sólo si la arandela para eje está bien fijada.

The two housing washers have tapered raceways and a guide flange; the shaft washer is flat. This means that these bearings can withstand a slight eccentricity of the shaft compared to the housing hole.

A shim is arranged between the two housing washers, which is proportioned so that, after assembly, a normal axial clearance for these bearings is obtained.

The double direction tapered thrust bearings are used to obtain satisfactory performance and suitable life only if the shaft washer is fixed firmly.

DIMENSIONES

Las dimensiones generales se establecen en base a las exigencias del principal sector industrial que emplea los rodamientos axiales de rodillos cónicos, es decir las instalaciones de laminación, pero dichas dimensiones no están unificadas.

DIMENSIONS

The overall dimensions are established based on the requirements of the main industrial field of application that utilises tapered roller thrust bearings, in other words rolling presses, even if such dimensions are not unified.

DESALINEACIÓN

Los rodamientos axiales de rodillos cónicos con arandelas planas no pueden afrontar ninguna desalineación entre el eje y el alojamiento.

DISPLACEMENT

The tapered roller thrust bearings with flat washers cannot withstand any displacement between the shaft and the housing.

TOLERANCIAS

Los diámetros interiores y exteriores de los rodamientos axiales de rodillos cónicos cumplen en general con las tolerancias de la clase de precisión normal.

Las tolerancias sobre la altura total y la precisión de marcha difieren de las prescritas para la clase normal.

TOLERANCES

The inside and outside diameters of the tapered roller thrust bearings generally comply with the tolerances of the normal precision class.

The tolerances on the total height and the running precision differ from those of the normal class.

JAULAS

Los rodamientos axiales de rodillos cónicos completamente llenos cuentan con una jaula mecanizada de latón.

CAGES

Tapered roller thrust bearings that are not fully filled have a solid brass cage.

RODAMIENTOS AXIALES DE RODILLOS CÓNICOS, DE DOBLE EFECTO TAPERED ROLLER THRUST BEARINGS, DOUBLE DIRECTION

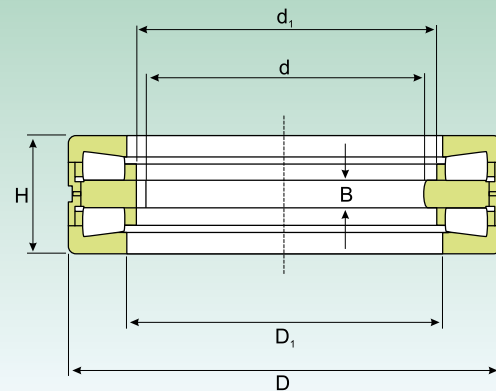

Dimensiones (mm) <i>Dimension (mm)</i>						Coeficiente de carga (KN) <i>Load rating (KN)</i>		Peso (Kg) <i>Weight (Kg)</i>	Sigla <i>Designation</i>
d (mm)	d ₁ (mm)	D (mm)	D ₁ (mm)	B (mm)	H (mm)	Dinámico <i>Dynamic</i> C	Estático <i>Static</i> C ₀		
170	182	240	184	20	84	323,4	1264,2	12,5	350980 C
180	192	280	196	20	90	549,78	2352	22,0	353162
220	231	300	236	22	96	431,2	1626,8	20,0	351019 C
240	251	320	256	22	96	409,64	1862	21,5	351182 C
250	265	380	275	22	100	879,06	4459	43,5	353005
260	276	360	285	20	92	592,9	2548	28,0	350981 C
270	300	450	310	45	180	1617	5880	120	351164 C
320	349	440	355	26	108	970,2	4557	48,5	353102 C
	340	470	350	30	130	1274	5586	80	350982 C
350	380	490	390	30	130	1146,6	4998	73,5	351100 C
	384	540	400	30	135	1685,6	8967	115	353006
380	416	560	430	32	130	1754,2	9800	110	351175 C
420	455	620	465	35	170	2371,6	11956	185	351121 C
440	480	645	490	50	167	1940,4	10584	190	353152
450	480	645	490	38	155	1940,4	10584	170	350916 D
470	515	720	536	50	200	3341,8	17248	285	353151
530	560	710	575	57	218	2156	10780	245	351475 C
550	585	760	610	50	230	2861,6	12936	310	350976 C
600	670	910	680	70	290	4635,4	20776	655	350901 C
670	705	900	725	50	230	3508,4	18620	425	351761 A
900	960	1180	990	48	220	3939,6	28420	605	353002





Rodamientos para bombas de agua

Water pump bearings



RODAMIENTOS PARA BOMBAS DE AGUA

Los rodamientos **ISB**[®] para bombas de agua, son de diseño simple y económico. Han sido concebidos para la utilización en la industria de los motores (para autos, camiones, tractores, motores marítimos). Tienen dos giros de bolas o bien uno de bolas y uno de rodillos, distanciados entre sí, para otorgarles mayor durabilidad y soportar cargas radiales mayores (**Fig. 1**). En lugar del aro interior se emplea un eje, con saliente por ambos lados, en el cual están montados, de una parte la polea de arrastre y de la otra el rodete de la bomba. El rodamiento está prelubricado con grasa de protección estanca que evita la necesidad de mantenimiento y está fabricado con un tratamiento térmico especial.

WATER PUMP BEARINGS

ISB[®] water pump bearings, are conceptually easy and cheap: they are designed for motor industry (engine cars, propelling motors, lorries, tractors and so on); they can be manufactured with double row of balls or with a row of balls and a row of rollers. They are distant, in order to have a longer life and be more resistant to heavy loads (**Fig. 1**). Instead of an inner ring, a shaft is used that puts out on both sides and onto which a carrying pulley and a rotor pump is mounted, one per each side. The bearing is pre-lubricated with grease, and sealed (2RS watertight version); these conditions guarantee the free maintenance of it; it is made of chrome-steel for bearings and subjected to special heat treatments. For tolerances, see technical drawing. C3 clearance is to guarantee longer life. Dynamic and static load rating are calculated by the assembly of 2 single row ball bearings.

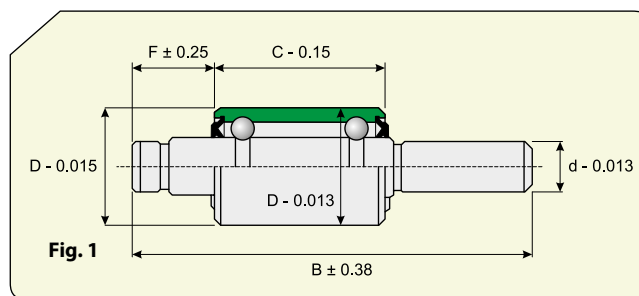
Fig. 1

Contáctenos para aplicaciones especiales. A continuación encuentra Usted algunos ejemplos de ejes de diseño especial (**Fig. 2**).

Consult us when special shaft designs are needed. Some examples of specially shaped shafts are given below (**Fig. 2**).

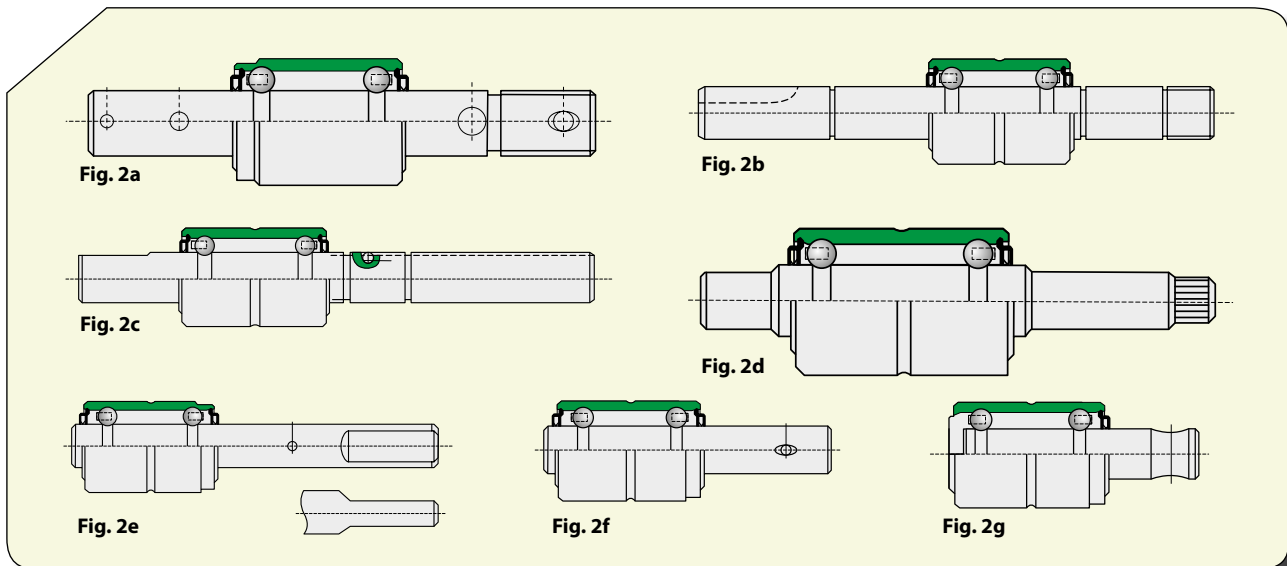
Fig. 2a
Fig. 2b
Fig. 2c
Fig. 2d
Fig. 2e
Fig. 2f
Fig. 2g

Bomba agua para automóviles (**Fig. 3**).

Water pump for automobile (**Fig. 3**).

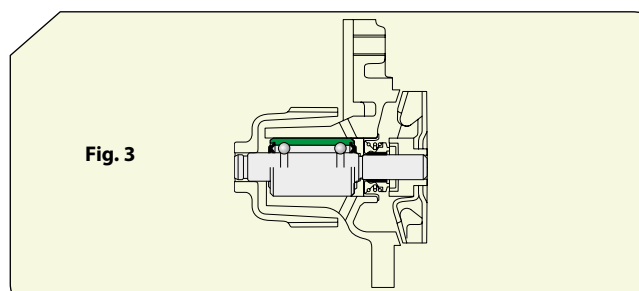
Fig. 3

Bomba agua para motos (Fig. 4).

Water pump for motorcycle (Fig. 4).

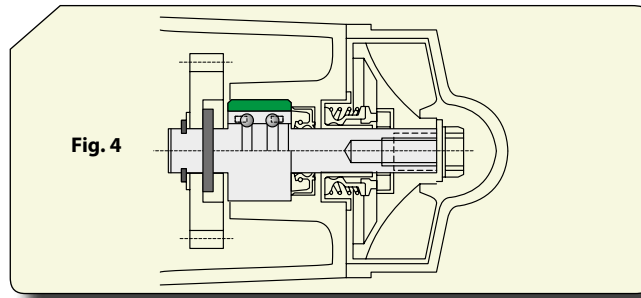

Rueda para máquina agrícola (Fig. 5).

Wheel for farm machines (Fig. 5).

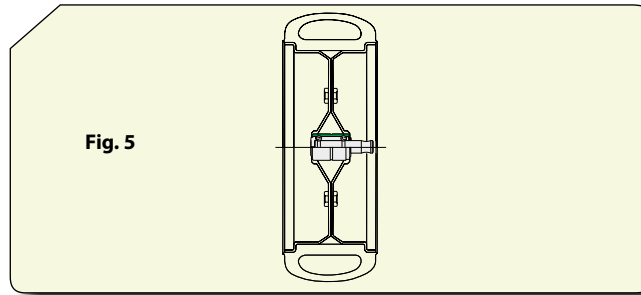

DIMENSIONES DE SERIE DE RODAMIENTOS

WATER PUMP BEARING DIMENSIONS SERIES

Dimensiones - Dimensions (mm)		Dimensiones - Dimensions (mm)	
Diámetro exterior Outside diameter	Diámetro eje Shaft diameter	Diámetro exterior Outside diameter	Diámetro eje Shaft diameter
26	12	35	17.5
28	17.2	35	18
30	15	38.1	18.961
30	15.918	41	22
30	16	42	22
30	17.2	47.625	25.4

ESTRUCTURA DE LA SIGLA DEL RODAMIENTO

WATER PUMP BEARING NUMBER STRUCTURE

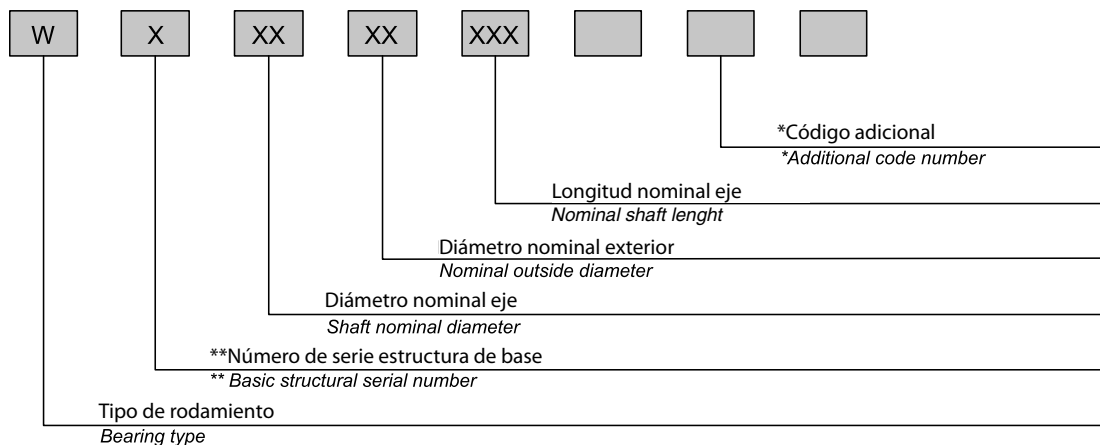

- * Para otros diámetros de los ejes se utilizan los símbolos A₁-A₂
- Para otros tamaños y estructuras se utilizan los símbolos K₁-K₂
- T** Eje roscado
- T** Eje perforado
- N** Eje moleteado
- F** Terminal del eje plano
- **B** Rodamiento de dos giros de bolas
- R** Rodamiento combinado con un giro de bolas y uno de rodillos

- * Different shaft diameter use the symbol A₁ - A₂
- Different dimensions of structure for integral shaft use K₁ - K₂
- T** Thread on shaft.
- R** Hole in shaft.
- N** Knurl on shaft.
- F** Flat milled on shaft.
- **B** Ball-ball type.
- R** Ball-roller type.

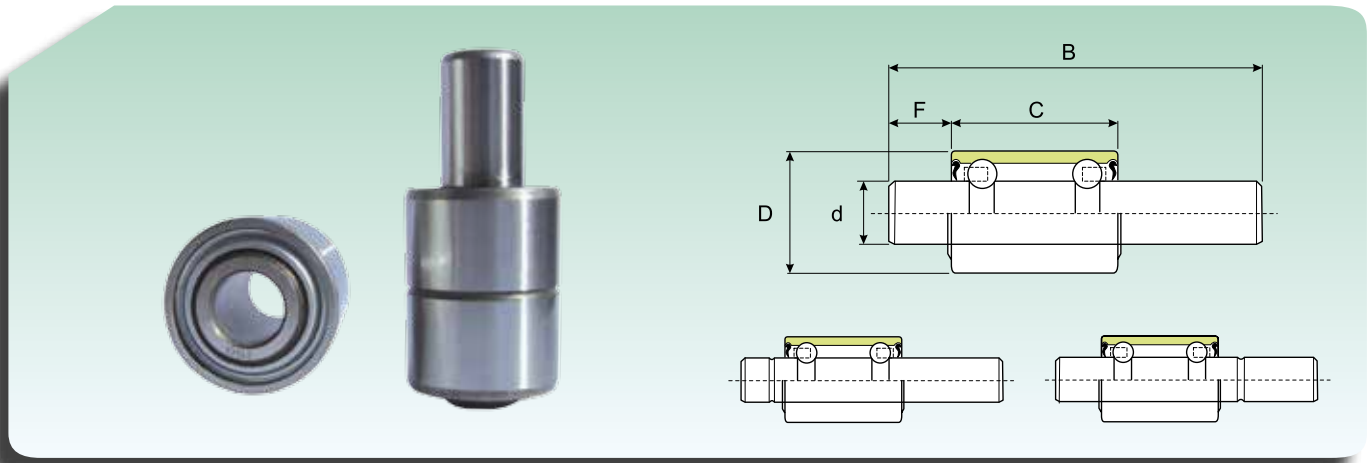
**RODAMIENTOS PARA BOMBAS DE AGUA
WATER PUMP BEARINGS**

Dimensiones Dimension					Sigla Designation
D (mm)	C (mm)	d (mm)	B (mm)	F (mm)	
26	39.00	12.00	89.5	16.5	WB1226090
	39.00	12.00	94.5	21.5	WB1226095
	39.00	12.00	105.5	16.5	WB1226108
	39.00	12.00	103.5	21.5	WB1226104
30	38.89	15.918	73.4	4.0	WB1630073
	38.89	15.918	82.6	4.0	WB1630083
	38.89	15.918	110.5	19.5	WB1630111
	38.89	15.918	103.2	23.4	WB1630103
	38.89	15.918	111.5	23.8	WB1630112
	38.89	15.918	127.8	25.8	WB1630128
	38.89	15.918	108.7	27.3	WB1630109
	38.89	15.918	101.2	27.5	WB1630101
	38.89	15.918	111.8	29.2	WB1630112K
	38.89	15.918	120.6	29.5	WB1630121
	38.89	15.918	105.2	30.1	WB1630105
	38.89	15.918	127.8	31.0	WB1630128K
	38.89	15.918	121.6	31.4	WB1630122
	38.89	15.918	113.1	31.7	WB1630113
	38.89	15.918	114.3	32.0	WB1630114
	38.89	15.918	154.0	34.0	WB1630154
	38.89	15.918	193.3	35.1	WB1630139
	38.89	15.918	160.0	35.1	WB1630150
	38.89	15.918	119.9	36.6	WB1630120
	38.89	15.918	119.1	37.3	WB1630119
	38.89	15.918	133.1	38.7	WB1630133
	38.89	15.918	125.0	39.0	WB1630125
	38.89	15.918	136.4	39.0	WB1630136
	38.89	15.918	142.9	40.0	WB1630143
	38.89	15.918	122.2	40.2	WB1630122K
	38.89	15.918	132.1	40.2	WB1630132
	38.89	15.918	134.0	42.6	WB1630134
	38.89	15.918	135.3	50.8	WB1630135
	38.89	15.918	135.7	52.4	EN1630138
	38.89	15.918	138.1	58.3	WB1630138
	38.89	15.918	161.9	58.3	WB1630162
	38.89	15.918	146.2	61.7	WB1630146
	38.89	15.918	159.5	76.2	WB1630160
38.89	15.918	123.4	40.6	WB1630123	
38.89	15.918	142.0	52.6	WB1630142	
38.1	54.00	18.961	144.5	29.0	WB1938145
	54.00	18.961	132.1	29.8	WB1938132
	54.00	18.961	134.1	30.3	WB1938134
	54.00	18.961	141.7	31.8	WB1938142
	54.00	18.961	143.3	35.3	WB1938143
	54.00	18.961	139.7	35.6	WB1938140
	54.00	18.961	162.4	35.8	WB1938152
	54.00	18.961	165.1	35.8	WB1938165



ELECTRICAL **M**OTORS **S**TANDARD

Rodamientos para aplicaciones "baja rumorosidad"

Bearings for "low noise" applications

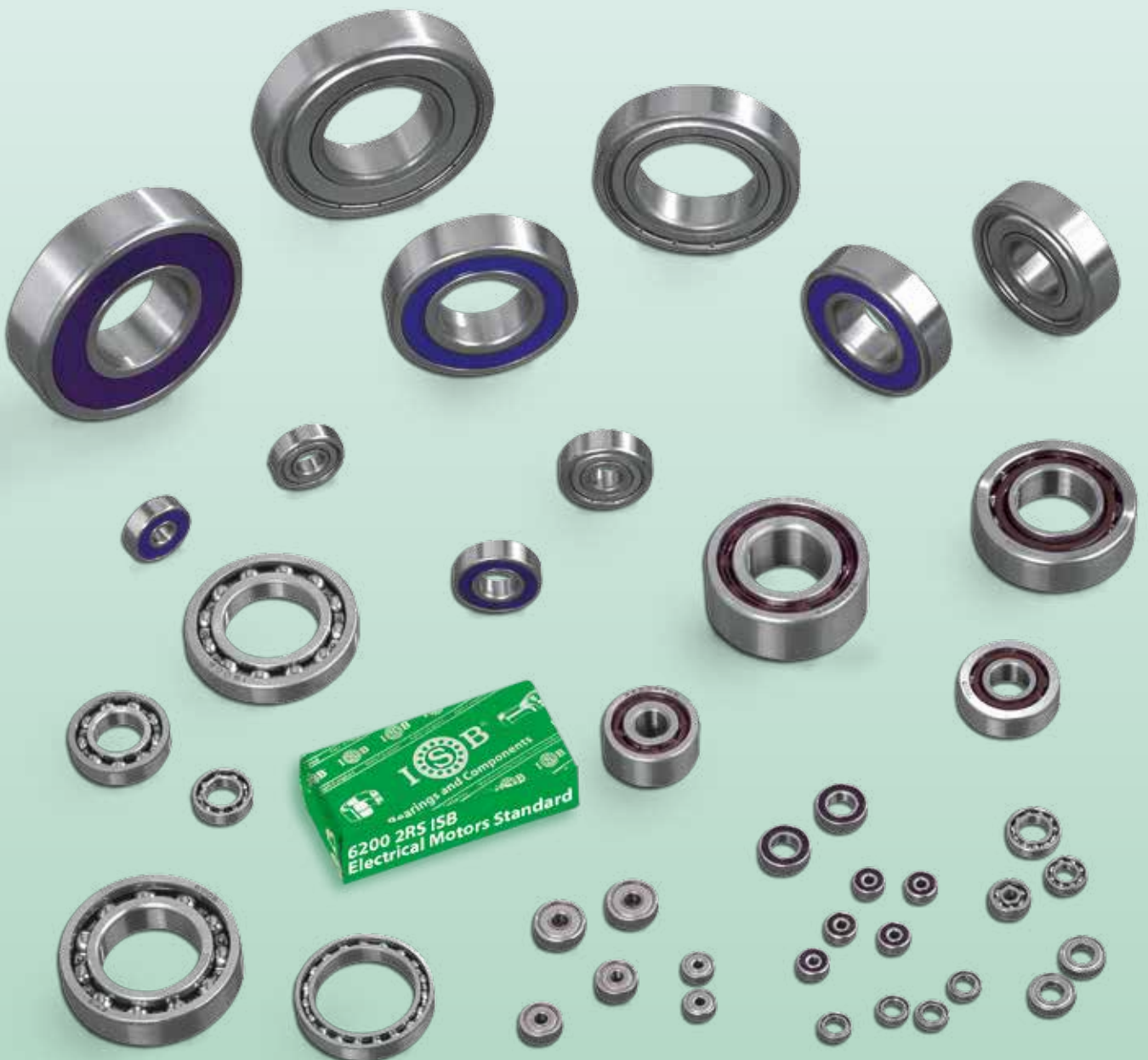

ISB[®], RODAMIENTOS BAJA RUMOROSIDAD...

Los rodamientos **ISB**[®] **ELECTRICAL MOTORS STANDARD** han sido especialmente estudiados, fabricados y seleccionados uno por uno, para aplicaciones donde se requiere la máxima silenciosidad y las mínimas vibraciones.

Un pool de empresas, con Sistema de Calidad certificado UNI EN ISO 9001:2008, gracias a su elevado know-how técnico y a la disponibilidad de máquinas de avanzada tecnología, controla atentamente la producción, garantizando por lo tanto un producto de elevada calidad.

Para rodamientos con particulares características técnicas y constructivas, las mismas empresas cuentan con oficinas técnicas capaces de resolver eventuales problemas inherentes al diseño y a la aplicación.

ISB[®], LOW NOISE BALL BEARINGS...

***ISB**[®] **ELECTRICAL MOTORS STANDARD** bearings have been carefully manufactured and individually selected for assembly on Electric Motors and other applications where low noise and vibration is of paramount importance.*

The production of these bearings is constantly monitored and checked only by companies who have full certification with System Quality UNI EN ISO 9001:2008. This ensures that, thanks to their knowledge and their use of bearings for special applications.

The technical staff of these companies are able to solve any difficulties customers may have arising from the need of bearings for special applications.

MATERIALES

Los aros interiores y exteriores, las bolas y las jaulas están fabricadas con un tipo especial de acero de alta calidad, conforme con las normas ISO y SAE 52100. A continuación se exponen las especificaciones técnicas.

MATERIALS

Inner and outer rings, balls and cages are made from a special type of high quality chrome steel in full accordance with ISO and SAE 52100 requirements. See below the technical specifications.

Componentes - Components	Tipo de acero - Steel type	Dureza - Hardness
Aro interior - Inner ring	Acero al cromo - Chrome steel 100 Cr6 (GCr15)	60 / 62,5 (± 0,5) HRC
Aro exterior - Outer ring	Acero al cromo - Chrome steel 100 Cr6 (GCr15)	60 / 62,5 (± 0,5) HRC
Jaula - Cage	Acero - Steel C40	—
Bolas - Balls*	Acero al cromo - Chrome steel 100 Cr6 (grado- grade G5)	60 / 65 (± 0,5) HRC

* Disponible bajo demanda con elevado grado de precisión - Available upon request with other precision grade

% Composición química del acero para rodamientos - Chemical composition of bearing steel %					
Carbono Carbon C	Silicio Silicon Si	Manganeso Manganese Mn	Fósforo Phosphorus P	Azufre Sulphur S	Cromo Chromium Cr
0,98 ~ 1,10	0,15 ~ 0,30	0,25 ~ 0,45	<0,025	<0,025	1,30 ~ 1,60

ESTRUCTURA DEL RODAMIENTO

BEARING STRUCTURE

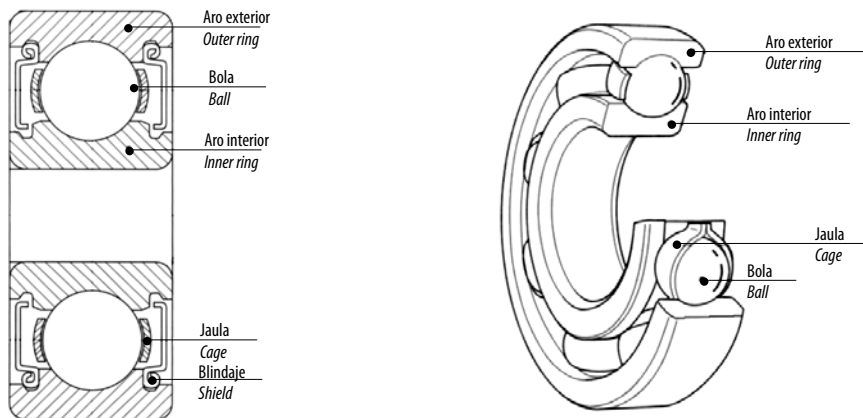

JAULA

CAGE



Jaula remachada
Rivet-type cage



Jaula con chavetero
Tongue-type cage



Jaula de poliamida reforzada con fibra de vidrio
Polyamide-type cage reinforced with glass fiber

LUBRIFICACIÓN

Los rodamientos para aplicaciones de "baja rumorosidad" están pre-lubricados con lubricantes especialmente estudiados para reducir el roce y el calor generado, contener la rumorosidad, proteger contra las contaminaciones y reducir los costes de mantenimiento para los usuarios finales.

Según las condiciones de aplicación, de la rotación del eje, de la temperatura de servicio, etc., es posible utilizar lubricantes diversos como se muestra en la tabla que sigue. En los rodamientos **ISB® ELECTRICAL MOTORS STANDARD** se emplean las siguientes grasas:

Kyodo Yushi Multitemp y Shell Alvania 2.

LUBRICATION

Ball bearings for "low noise" applications are pre-lubricated with special lubricants purposely designed to reduce friction and heat, to limit noise, to protect from contamination thus reducing maintenance costs for the end user.

It is possible to use different lubricants depending application conditions. Please see table below.

*Greases used in **ISB® ELECTRICAL MOTORS STANDARD** bearings are as follows:*

Kyodo Yushi Multitemp and Shell Alvania 2.

COMPARACIÓN ENTRE LUBRICACIÓN CON GRASA Y LUBRICACIÓN CON ACEITE

COMPARISON BETWEEN GREASE LUBRICATION AND OIL LUBRICATION

Descripción <i>Specification</i>	Lubricación con grasa <i>Grease lubrication</i>	Lubricación con aceite <i>Oil lubrication</i>
Alojamientos y obturaciones <i>Housing and seals</i>	Simple <i>Simple</i>	Atención!!! Mantenimiento requerido <i>Careful!!! Maintenance required</i>
Velocidad <i>Speed</i>	Velocidad máxima entre 65% y 80% de la lubricación con aceite <i>Max speed between 65% and 80% of oil lubrication</i>	Límite de velocidad más alto <i>Higher limit speed</i>
Refrigeración <i>Cooling</i>	Escasa <i>Poor</i>	—
Fluidez <i>Fluidity</i>	Escasa <i>Poor</i>	Buena <i>Good</i>
Relubricación total <i>Total re-lubrication</i>	A veces difícil <i>Sometimes is difficult</i>	Simple <i>Easy</i>
Desmontaje piezas externas <i>Removal of external parts</i>	Desmontaje imposible <i>Impossible removal</i>	Simple <i>Easy</i>
Contaminación exterior debida a pérdidas <i>External contamination due to leakage</i>	Pocas contaminaciones por pérdidas <i>Rare contamination by leakage</i>	Si no se toman medidas existen muchas pérdidas. Desaconsejado en caso de contaminaciones exteriores. Evitar <i>Frequent leakage. No suitable if external contamination has to be avoided</i>

CLASES DE PRECISIÓN

Los rodamientos **ISB® ELECTRICAL MOTORS STANDARD** se fabrican con tolerancias de elaboración conformes con las normas ISO.

Normalmente se realizan con clase de precisión 6.

Clases de precisión mayores se pueden suministrar bajo demanda del Cliente.

PRECISION CLASS

ISB® ELECTRICAL MOTORS STANDARD bearings are manufactured with precision class tolerances according to ISO standards. They are usually supplied with precision class 6.

At Customer's request or for special applications, they can be supplied with a higher precision class.

Estándar	Clase de tolerancia / Tolerance class			
ISO	0	6	5	4
DIN	P0	P6	P5	P4
ANSI	ABEC - 1	ABEC - 3	ABEC - 5	ABEC - 7

Símbolos

Símbolos		Symbols
Diámetro nominal del orificio	d	Nominal bore diameter
Diámetro medio del orificio	d_{mp}	Mean bore diameter
Variación del diámetro del orificio	V_{dp}	Bore diameter variation
Variación del diámetro medio del orificio	V_{dmp}	Mean bore diameter variation
Diferencia del diámetro del orificio respecto al valor nominal ($\Delta_{dmp}=dmp-d$)	Δ_{dmp}	Deviation of the mean bore diameter ($\Delta_{dmp}=dmp-d$)
Diámetro nominal exterior	D	Nominal outer diameter
Diámetro exterior medio	D_{mp}	Mean outer diameter
Variación del diámetro exterior	V_{Dp}	Outer diameter variation
Variación del diámetro medio exterior	V_{Dmp}	Mean outer diameter variation
Diferencia del diámetro exterior medio ($\Delta_{Dmp}=Dmp-D$)	Δ_{Dmp}	Deviation of the mean outer diameter ($\Delta_{Dmp}=Dmp-D$)
Concentricidad de rotación del aro interior del rodamiento completo (precisión radial de rotación)	K_{ia}	Rotation concentricity of the bearing inner ring (run out radial precision)
Concentricidad de rotación del aro exterior del rodamiento completo (precisión radial de rotación)	K_{ea}	Concentricity radial run out of assembled bearing outer ring (run out radial precision)
Medida nominal de la altura del aro interior	B	Nominal height of the inner ring
Medida nominal de la altura del aro exterior	C	Nominal height of the outer ring
Medida individual de la altura del aro interior y del aro exterior	B_S - C_S	Single height of the inner and outer ring
Diferencia de una única medida de la altura del aro interior respecto a la dimensión nominal ($\Delta_{Bs}=Bs-B$)	Δ_{Bs}	Inner ring single width deviation ($\Delta_{Bs}=Bs-B$)
Diferencia de una única medida de la altura del aro exterior respecto a la dimensión nominal ($\Delta_{Cs}=Cs-C$)	Δ_{Cs}	Deviation of outer ring single width ($\Delta_{Cs}=Cs-C$)
Variación del ancho del aro (diferencia entre valores máximos y mínimos de las diferentes medidas del aro interior y exterior)	V_{Bs} - V_{Cs}	Inner and outer ring width variation
Defecto de cuadratura de las caras respecto al orificio del aro interior	S_d	Side face run out with reference to bore of the inner ring
Variación de la inclinación cilíndrica exterior respecto a la superficie lateral del aro exterior	S_D	Variation of the inclination of outside cylindrical surface to outer ring side face
Planaridad de rotación de la superficie lateral del aro interior respecto al camino de rodadura del rodamiento rígido completo (precisión axial de rotación)	S_{ia}	Side face run out of assembled inner ring with reference to raceway
Planaridad de rotación de la superficie lateral del aro exterior respecto al camino de rodadura del rodamiento rígido completo (precisión axial de rotación)	S_{ea}	Side face run out of assembled outer ring with reference to raceway

CLASE DE PRECISIÓN P0 (ABEC-1)

PRECISION CLASS P0 (ABEC-1)

ARO INTERIOR / INNER RING

μm.

d (mm)		Δ _{dmp}		V _{dp}			V _{dmp}	K _{ia}	Δ _{Bs}		V _{Bs}		
				Serie diametrales Diameter series					máx	máx		máx	mín
				9	0,1	2,3,4							
más de over	hasta up to	máx	mín	máx			máx	máx	máx	mín	máx		
0,6	2,5	0	-8	10	8	6	6	10	0	-40	12		
2,5	10	0	-8	10	8	6	6	10	0	-120	15		
10	18	0	-8	10	8	6	6	10	0	-120	20		
18	30	0	-10	13	10	8	8	13	0	-120	20		
30	50	0	-12	15	12	9	9	15	0	-120	20		
50	80	0	-15	19	19	11	11	20	0	-150	25		

ARO EXTERIOR / OUTER RING

μm.

D (mm)		Δ _{Dmp}		V _{Dp}				V _{Dmp}	K _{ea}	Δ _{Cs}		V _{Cs}		
				Rodamientos abiertos Open bearings		Rodamientos cerrados Closed bearings				máx	máx		máx	mín
				Serie diametrales Diameter series										
más de over	hasta up to	máx	mín	9	0,1	2,3,4	2,3,4	máx	máx	máx	mín	máx		
2,5	6	0	-8	10	8	6	10	6	15	Igual a Δ _{Bs} y V _{Bs} para aro interior del mismo rodamiento Identical to Δ _{Bs} and V _{Bs} of the inner ring of the relevant bearing				
6	18	0	-8	10	8	6	10	6	15					
18	30	0	-9	12	9	7	12	7	15					
30	50	0	-11	14	11	8	16	8	20					
50	80	0	-13	16	13	10	20	10	25					
80	120	0	-15	19	19	11	26	11	35					
120	150	0	-18	23	23	14	30	14	40					

CLASE DE PRECISIÓN P6 (ABEC-3)

PRECISION CLASS P6 (ABEC-3)

ARO INTERIOR / INNER RING

µm.

d (mm)		Δ _{dmp}		V _{dp}			V _{dmp}	K _{ia}	Δ _{Bs}		V _{Bs}		
				Serie diametrales Diameter series					máx	máx		máx	mín
				9	0,1	2,3,4							
más de over	hasta up to	máx	mín	máx			máx	máx	máx	mín	máx		
0,6	2,5	0	-7	9	7	5	5	5	0	-40	12		
2,5	10	0	-7	9	7	5	5	6	0	-120	15		
10	18	0	-7	9	7	5	5	7	0	-120	20		
18	30	0	-8	10	8	6	6	8	0	-120	20		
30	50	0	-10	13	10	8	8	10	0	-120	20		
50	80	0	-12	15	15	9	9	10	0	-150	25		

ARO EXTERIOR / OUTER RING

µm.

D (mm)		Δ _{Dmp}		V _{Dp}				V _{Dmp}	K _{ea}	Δ _{Cs}		V _{Cs}		
				Rodamientos abiertos Open bearings			Rodamien- tos cerrados Closed bearings			máx	máx		máx	mín
				Serie diametrales Diameter series										
				9	0,1	2,3,4	2,3,4							
más de over	hasta up to	máx	mín	máx			máx	máx	máx	mín	máx			
2,5	6	0	-7	9	7	5	9	5	8	Igual a Δ _{Bs} y V _{Bs} para aro interior del mismo rodamiento Identical to Δ _{Bs} and V _{Bs} of the inner ring of the relevant bearing				
6	18	0	-7	9	7	5	9	5	8					
18	30	0	-8	10	8	6	10	6	9					
30	50	0	-9	11	9	7	13	7	10					
50	80	0	-11	14	11	8	16	8	13					
80	120	0	-13	16	16	10	20	10	18					
120	150	0	-15	19	19	11	25	11	20					

CLASE DE PRECISIÓN P5 (ABEC-5)

PRECISION CLASS P5 (ABEC-5)

ARO INTERIOR / INNER RING

μm.

d (mm)		Δ _{dmp}		V _{dp}		V _{dmp}	K _{ia}	S _d	S _{ia}	Δ _{Bs}		V _{Bs}	
				Serie diametrales Diameter series						máx	mín		máx
				9	0,1,2,3,4								
más de over	hasta up to	máx	mín	máx		máx	máx	máx	máx	máx	mín	máx	
0,6	2,5	0	-5	5	4	3	4	7	7	0	-40	5	
2,5	10	0	-5	5	4	3	4	7	7	0	-40	5	
10	18	0	-5	5	4	3	4	7	7	0	-80	5	
18	30	0	-6	6	5	3	4	8	8	0	-120	5	
30	50	0	-8	8	6	4	5	8	8	0	-120	5	
50	80	0	-9	9	7	5	5	8	8	0	-150	6	

ARO EXTERIOR / OUTER RING

μm.

D (mm)		Δ _{Dmp}		V _{Dp}		V _{Dmp}	K _{ea}	S _D	S _{ea}	Δ _{Cs}		V _{Cs}	
				Serie diametrales Diameter series						máx	mín		máx
				9	0,1,2,3,4								
más de over	hasta up to	máx	mín	máx		máx	máx	máx	máx	máx	mín	máx	
2,5	6	0	-5	5	4	3	5	8	8	Igual a Δ _{Bs} y V _{Bs} para aro interior del mismo rodamiento Identical to Δ _{Bs} and V _{Bs} of the inner ring of the relevant bearing			
6	18	0	-5	5	4	3	5	8	8				
18	30	0	-6	6	5	3	6	8	8				
30	50	0	-7	7	5	4	7	8	8				
50	80	0	-9	9	7	5	8	8	10				
80	120	0	-10	10	8	5	10	9	11				
120	150	0	-11	11	8	6	11	10	13				

CLASE DE PRECISIÓN P4 (ABEC-7)
PRECISION CLASS P4 (ABEC-7)
ARO INTERIOR / INNER RING

μm.

d (mm)		Δ _{dmp}		Δ _{ds}		V _{dp}		V _{dmp}	K _{ia}	S _d	S _{ia}	Δ _{Bs}		V _{Bs}		
						Serie diametrales Diameter series						máx	mín		máx	mín
						7,8,9	1,7,2,3,4									
más de over	hasta up to	máx	mín	máx	mín	máx		máx	máx	máx	máx	máx	mín	máx		
0,6	2,5	0	-4	0	-4	4	3	2	2,5	3	3	0	-40	2,5		
2,5	10	0	-4	0	-4	4	3	2	2,5	3	3	0	-40	2,5		
10	18	0	-4	0	-4	4	3	2	2,5	3	3	0	-80	2,5		
18	30	0	-5	0	-5	5	4	2,5	3	4	4	0	-120	2,5		
30	50	0	-6	0	-6	6	5	3	4	4	4	0	-120	3		
50	80	0	-7	0	-7	7	5	3,5	4	5	5	0	-150	4		

ARO EXTERIOR / OUTER RING

μm.

D (mm)		Δ _{Dmp}		Δ _{Ds}		V _{Dp}		V _{Dmp}	K _{ea}	S _D	S _{ea}	Δ _{Cs}		V _{Cs}		
						Serie diametrales Diameter series						máx	mín		máx	mín
						7,8,9	1,7,2,3,4									
más de over	hasta up to	máx	mín	máx	mín	máx		máx	máx	máx	máx	máx	mín	máx		
2,5	6	0	-4	0	-4	4	3	2	3	4	5	Igual a Δ _{Bs} y V _{Bs} para aro interior del mismo rodamiento Identical to Δ _{Bs} and V _{Bs} of the inner ring of the relevant bearing				
6	18	0	-4	0	-4	4	3	2	3	4	5					
18	30	0	-5	0	-5	5	4	2,5	4	4	5					
30	50	0	-6	0	-6	6	5	3	5	4	5					
50	80	0	-7	0	-7	7	5	3,5	5	4	5					
80	120	0	-8	0	-8	8	6	4	6	5	6					
120	150	0	-9	0	-9	9	7	5	7	5	7					

JUEGO RADIAL

El juego radial de los rodamientos está determinado por el desplazamiento en sentido radial (de una a otra parte) del aro interior respecto al aro exterior.

Los rodamientos **ISB® ELECTRICAL MOTORS STANDARD** se fabrican con juego radial "normal" y se utilizan para empleos comunes, garantizando parámetros satisfactorios de funcionamiento.

Si el juego radial es diferente al normal, se evidencia añadiendo un sufijo a la referencia del rodamiento (por ejemplo: 6005 C3). La tabla que sigue a continuación muestra los valores de los juegos radiales.

RADIAL CLEARANCE

The radial clearance of bearings is determined by the radial movement (from one side to the other between the inner ring and the outer track).

The **ISB® ELECTRICAL MOTORS STANDARD** bearings are constructed with "normal" radial clearance, in order to satisfy common applications.

If the radial play differs from the standard, it can be recognized with a suffix that identifies the type of bearing (example: 6005 C3). The following table shows the values for radial clearances.

TABLA JUEGO RADIAL DE LOS RODAMIENTOS DE BOLAS

TABLES OF RADIAL CLEARANCE FOR BALL BEARINGS

µm.

Diámetro del orificio (mm) Bore diameter (mm)		C2		Normal Normal		C3		C4		C5	
Más de Over	Hasta Up to	Mín	Máx	Mín	Máx	Mín	Máx	Mín	Máx	Mín	Máx
2,5	10	0	7	2	13	8	23	14	29	20	37
10	18	0	9	3	18	11	25	18	33	25	45
18	24	0	10	5	20	13	28	20	36	28	48
24	30	1	11	5	20	13	28	23	41	30	53
30	40	1	11	6	20	15	33	28	46	40	64
40	50	1	11	6	23	18	36	30	51	45	73
50	65	1	15	8	28	23	43	38	61	55	90

VIBRACIONES Y RUMOROSIDAD

Los rodamientos **ISB® ELECTRICAL MOTORS STANDARD** se fabrican siguiendo los valores de rumorosidad y vibración indicados en las tablas que siguen, en particular pueden ser fabricados en ejecución "Low Noise-Z₃ V₃" o bien en ejecución "Low Noise Plus - Z_p V_p".

VIBRATIONS AND NOISE

ISB® ELECTRICAL MOTORS STANDARD bearings have been manufactured in accordance with the values shown in the tables below. In particular they are available in Z₃-V₃ noiseless "Low Noise" or "Z_p - V_p Low Noise Plus" version.

TABLA TOLERANCIAS DE LAS VIBRACIONES

VIBRATIONS TOLERANCES TABLE

µm./s

d mm	V			V ₁			V ₂			V ₃			V ₄			V _p		
	Bajo Low	Medio Medium	Alto High	Bajo Low	Medio Medium	Alto High	Bajo Low	Medio Medium	Alto High	Bajo Low	Medio Medium	Alto High	Bajo Low	Medio Medium	Alto High	Bajo Low	Medio Medium	Alto High
3,4	80	44	44	60	35	32	48	26	22	31	16	15	28	10	10	25	10	10
5,6	110	72	60	74	48	40	58	36	30	35	21	18	32	11	11	25	12	10
7,8	130	96	80	92	66	54	72	48	40	44	28	24	38	12	12	35	14	12
9	130	96	80	92	66	54	72	48	40	44	28	24	38	12	12	40	16	14
10	160	120	100	120	80	70	90	60	50	55	35	30	45	14	15	45	22	20
12	160	120	100	120	80	70	90	60	50	55	35	30	45	14	15	45	24	22
15	210	150	120	150	100	85	110	78	60	65	46	35	52	18	18	50	32	26
17	210	150	120	150	100	85	110	78	60	65	46	35	52	25	25	50	35	30
20	260	190	150	180	125	100	130	100	75	80	60	45	60	25	25	60	40	35
22,25	260	190	150	180	125	100	130	100	75	80	60	45	60	30	32	70	40	35
28	260	190	150	180	125	100	130	100	75	80	60	45	60	35	40	55	31	28
30,32	300	240	190	200	150	130	150	120	100	90	75	60	70	35	40	80	50	45
35	300	240	190	200	150	130	150	120	100	90	75	60	70	42	45	80	50	40
40	360	300	260	240	180	160	180	150	130	110	90	80	82	50	50	100	80	60
45	360	300	260	240	180	160	180	150	130	110	90	80	82	60	60	120	80	70
50	420	320	320	280	200	200	210	160	160	125	100	100	95	70	70	140	100	80

TABLA TOLERANCIAS DE LA RUMOROSIDAD

NOISE TOLERANCES TABLE

dB

d mm	Serie diametrales (60...) Diameter series (60...)					Serie diametrales (62...) Diameter series (62...)						Serie diametrales (63...) Diameter series (63...)					
	Z	Z ₁	Z ₂	Z ₃	Z _p	Z	Z ₁	Z ₂	Z ₃	Z ₄	Z _p	Z	Z ₁	Z ₂	Z ₃	Z ₄	Z _p
3	35	34	32	28	26	36	35	32	30	-	26	37	36	33	31	-	26
4	35	34	32	28	26	36	35	32	30	-	26	37	36	33	31	-	26
5	37	36	34	30	26	38	37	34	32	-	26	39	37	35	33	-	26
6	37	36	34	30	22	38	37	34	32	-	23	39	37	35	33	-	24
7	39	38	35	31	22	40	38	36	34	-	23	-	-	-	-	-	24
8	39	38	35	31	23	40	38	36	34	-	24	-	-	-	-	-	25
9	41	40	36	32	24	42	40	37	35	-	25	-	-	-	-	-	26
10	43	42	38	33	24	44	42	39	35	30	25	46	44	40	37	32	26
12	44	43	39	34	26	45	43	39	35	30	27	47	45	40	37	32	28
15	45	44	40	35	28	46	44	41	36	31	29	48	46	42	38	33	30
17	46	44	40	35	31	47	45	41	36	31	32	49	47	42	38	33	33
20	47	45	41	36	34	48	46	42	38	33	35	50	48	43	39	34	36
22	47	45	41	36	35	48	46	42	38	33	36	50	48	43	39	34	35
25	48	46	42	38	35	49	47	43	40	36	36	51	49	44	41	37	39
28	49	47	43	39	36	50	48	44	41	37	37	52	50	45	42	38	37
30	49	47	43	39	37	50	48	44	41	37	38	52	50	45	42	38	40
32	50	48	44	40	38	51	49	45	42	38	39	53	51	46	43	39	39
35	51	49	45	41	40	52	50	46	43	39	40	54	52	47	44	40	42
40	53	51	46	42	42	54	52	47	44	40	42	56	54	49	45	41	43
45	55	53	48	45	43	56	54	49	46	43	43	58	56	51	47	44	42
50	57	54	50	47	44	58	55	51	48	45	44	60	57	53	49	46	43
55	59	56	52	49	45	60	57	53	50	47	45	62	59	54	51	48	47
60	61	58	54	51	47	62	59	54	51	48	47	64	61	56	53	50	48

SUFIJOS DE LOS RODAMIENTOS

BEARINGS SUFFIXS

Blindaje de metal no deslizante de un lado del rodamiento	Z	Metal shield at one side of the bearing
Blindaje de metal no deslizante de ambos lados del rodamiento	ZZ	Metal shield at both sides of the bearing
Obturación de goma deslizante de un lado del rodamiento	RS	Rubber seal at one side of the bearing
Obturación de goma deslizante de ambos lados del rodamiento	2RS	Rubber seal at both sides of the bearing
Obturación de goma de baja fricción reforzada con una chapa de acero a un lado del rodamiento	RZ	Low friction rubber seal reinforced with steel, at one side of the bearing
Obturación de goma de baja fricción reforzada con una chapa de acero a ambos lados del rodamiento	2RZ	Low friction rubber seal reinforced with steel, at both sides of the bearing
Obturación de goma con fricción media	2RV	Medium friction rubber seals

BLINDAJES Y OBTURACIONES

SHIELDS AND SEALS

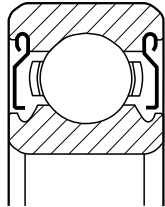
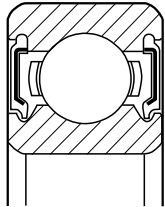
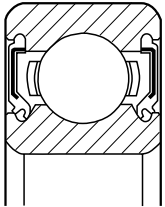
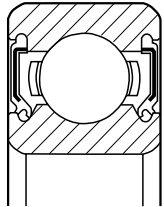
Marca y descripción Brand and specification	Blindado - Shielded		Con obturación - Sealed	
	Sin contacto Non-contact type	Sin contacto Non-contact type	A contacto Contact type	Tipo "baja torsión" "Low torque" type
ISB	ZZ	2RZ	2RS	2RV
NSK	ZZ	VV	DDU	DDW
NTN	ZZ	LLB	LLU	LLH
Estructura Structure				
Torsión Torque	Bajo Low	Bajo Low	Bastante alto Rather high	Medio Medium
Resistente al polvo Dust proofing	Muy bueno Very good	Mejor que el ZZ Better than ZZ-type	Excelente Excellent	Mucho mejor que el 2RZ Much better than 2RZ-type
Resistencia al agua Water proofing	Escasa Poor	Escasa Poor	Muy bueno Very good	Muy bueno Very good
Capacidad de alta velocidad High speed capacity	Cómo el tipo abierto Same as open type	Cómo el tipo abierto Same as open type	Limitado por el aro de contacto Limited by contact seals	Mucho mejor que el 2RS Much better than 2RS-type
Temperatura permitida Allowable temperature range	Depende del lubricante Depends on lubricant	-25 °C ~ +120 °C	-25 °C ~ +110 °C	-25 °C ~ +120 °C

DIMENSIÓN DE LOS RACORES (BISEL)

- r_1, r_3 = biseles en dirección central
- r_2, r_4 = biseles en dirección axial
- $r_s \text{ min}$ = símbolo limite máximo biseles r_1, r_2, r_3, r_4 ,
- $r_{1s} \text{ max}, r_{3s} \text{ max}$ = dimensión máxima en dirección radial
- $r_{2s} \text{ max}, r_{4s} \text{ max}$ = dimensión máxima en dirección axial

DIMENSIONES LIMITE RACORES PARA RODAMIENTOS RÍGIDOS Y AXIALES

Diámetro del orificio Bore diameter			Rodamientos rígidos Radial bearings		Rodamientos axiales Thrust bearings
$r_s \text{ min}$	d		$r_{1s}, r_{3s} \text{ máx}$	$r_{2s}, r_{4s} \text{ máx}$	$r_{1s}, r_{2s} \text{ máx}$
	más de over	hasta up to			
0,1	-	-	0,2	0,4	0,2
0,15	-	-	0,3	0,6	0,3
0,2	-	-	0,5	0,8	0,5
0,3	-	40	0,6	1	0,8
	40	-	0,8	1	0,8
0,6	-	40	1	2	1,5
	40	-	1,3	2	1,5
1	-	50	1,5	3	2,2
	50	-	1,9	3	2,2
1,1	-	120	2	3,5	2,7
	120	-	2,5	4	2,7
1,5	-	120	2,3	4	3,5
	120	-	3	5	3,5
2	-	80	3	4,5	4
	220	-	3,8	6	4
	80	220	3,5	5	4
2,1	-	100	3,8	6	4,5
	-	280	4	6,5	4,5
	280	-	4,5	7	4,5
2,5	100	280	4,5	6	-
	280	-	5	7	-
3	-	280	5	8	5,5
	280	-	5,5	8	5,5
4	-	-	6,5	9	6,5
5	-	-	8	10	8
6	-	-	10	13	10
7,5	-	-	12,5	17	12,5
9,5	-	-	15	19	15
12	-	-	18	24	18
15	-	-	21	30	21
19	-	-	25	38	25

MOUNTING CHAMFER DIMENSIONS

TOLERANCES

- r_1, r_3 = chamfer dimension in radial direction
- r_2, r_4 = chamfer dimension in axial direction
- $r_s \text{ min}$ = general symbol for minimum limit r_1, r_2, r_3, r_4 ,
- $r_{1s} \text{ max}, r_{3s} \text{ max}$ = maximum dimension in radial direction
- $r_{2s} \text{ max}, r_{4s} \text{ max}$ = maximum dimension in axial direction

MOUNTING CHAMFER DIMENSION LIMITS FOR RADIAL AND THRUST BEARINGS

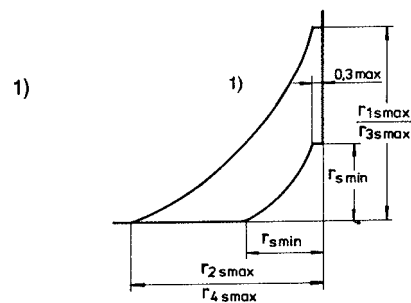
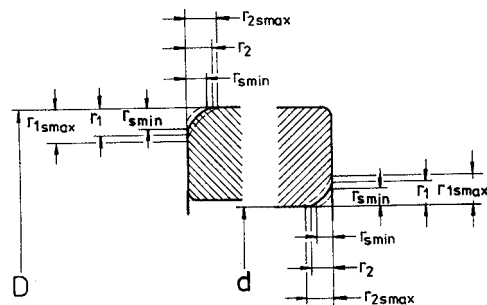
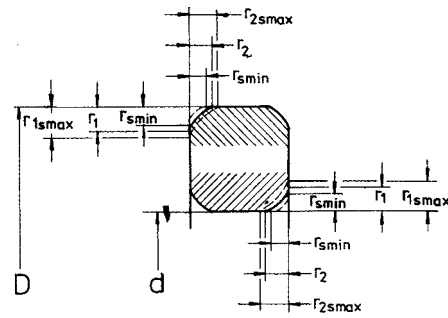

1) Solo para $d < 30 \text{ mm}$
1) Only for $d < 30 \text{ mm}$

MANTENIMIENTO

ANOMALÍAS EN EL FUNCIONAMIENTO DE UN RODAMIENTO: CAUSAS PROBABLES Y ACCIONES CORRECTIVAS

ANOMALÍA	CAUSAS PROBABLES	ACCIONES CORRECTIVAS
Fuerte ruido metálico	Carga anómala	Seleccionar con mayor cuidado el acoplamiento, el juego interior, la pre-carga, la posición del apoyo lateral del alojamiento, etc.
	Montaje incorrecto	Mejorar la precisión de la elaboración, la alineación del eje y del alojamiento, el método de montaje
	Lubricante no adecuado y/o insuficiente	Seleccionar un lubricante más adecuado o agregar lubricante
	Juego excesivo	Seleccionar un rodamiento de clase más silenciosa o bien con juego reducido
	Contacto entre las partes rotativas	Modificar la obturación del laberinto, etc
Fuerte ruido regular	Resquebrajamientos, corrosión o abrasiones en los caminos de rodadura	Sustituir o lavar bien el rodamiento, mejorar el sistema de obturación y usar lubricantes limpios
	Efecto Brinell	Sustituir el rodamiento, manipularlo y montarlo con cuidado
	Soldadura en el camino de rodadura	Sustituir el rodamiento
Ruido irregular	Juego excesivo	Seleccionar con más cuidado el acoplamiento, el juego interno, la pre-carga
	Penetración de partículas extrañas	Sustituir o lavar bien el rodamiento, mejorar el sistema de obturación y usar lubricantes limpios
	Agrietamientos o soldaduras en los cuerpos rodantes	Sustituir el rodamiento
Aumento irregular de la temperatura	Excesiva cantidad de lubricante	Reducir la cantidad, seleccionar una grasa más consistente
	Lubricante no adecuado e insuficiente	Seleccionar un lubricante más adecuado o agregar lubricante
	Carga anómala	Seleccionar con mayor cuidado el acoplamiento, el juego interior, la pre-carga, la posición del apoyo lateral del alojamiento, etc.
	Montaje incorrecto	Mejorar la precisión de la elaboración, la alineación del eje y del alojamiento, el método de montaje
	Deslizamiento de las superficies acopladas, excesiva fricción por causa de las obturaciones	Modificar o sustituir las obturaciones, sustituir el rodamiento, seleccionar con más cuidado el acoplamiento y el método de montaje
Vibraciones (precisión axial de rotación)	Efecto Brinell	Sustituir el rodamiento, manipularlo y montarlo con cuidado
	Descamación	Sustituir el rodamiento
	Montaje incorrecto	Mejorar la ortogonalidad entre el eje y el apoyo lateral del alojamiento o el plano de apoyo del separador.
	Penetración de partículas extrañas	Sustituir o lavar bien el rodamiento, mejorar el sistema de obturación y usar lubricantes limpios
Pérdidas o alteraciones de color del lubricante	Excesiva lubricación	Reducir la cantidad, seleccionar una grasa más consistente
		Sustituir el rodamiento o el lubricante Limpiar el alojamiento y las partes adyacentes

MAINTENANCE

ANOMALIES IN THE WORKING OF A BEARING: POSSIBLE CAUSES AND CORRECTIVE ACTIONS

ANOMALY	POSSIBLE CAUSES	CORRECTIVE ACTIONS
Strong clang	Anomalous load	To select more carefully the fit, the internal clearance, the preloading, the position of housing shoulder
	Incorrect assembling	To improve the precision of the manufacturing, the alignment of the shaft and of the housing, the assembling method
	Inadequate or insufficient lubricant	To select a better lubricant or to replenish the lubricant
	Excessive clearance	To select a bearing of a more silent class or with reduced clearance
	Contact between the rotating parts	To modify the labyrinth seal etc
Strong regular sound	Cracks, corrosion or abrasion on the raceways	To substitute or wash accurately the bearing, to improve the seal system and use clean lubricants
	Pitting	To substitute the bearing, handle and assemble it with care
	Welding on the raceways	To substitute the bearing
Irregular sound	Excessive clearance	To select more carefully the fit, the internal clearance, the preloading
	Penetration of extraneous particles	To substitute or wash accurately the bearing, to improve the seal system and use clean lubricant
	Cracks or wildings on the rolling elements	To substitute the bearing
Irregular increase of the temperature	Excessive quantity of lubricant	To reduce the quantity, to select a grease more consistency
	Inadequate or insufficient lubricant	To select a better lubricant or to replenish the lubricant
	Anomalous load	To select more carefully the fit, the internal clearance, the preloading, the position of housing shoulder
	Incorrect assembling	To improve the precision of the manufacturing, the alignment of the shaft and of the housing, the assembling method
	Relative sliding of connected surface, excessive friction of the seals	To modify or substitute the seals, to substitute the bearing, to select more carefully the fit and the assembling method
Vibrations (running axial accuracy)	Pitting	To substitute the bearing, handle and assemble it with care
	Flaking off	To substitute the bearing
	Incorrect assembling	To improve the orthogonality between the shaft and the housing shoulder or the support surface of the space collar
	Penetration of extraneous particles	To substitute or wash accurately the bearing, to improve the seal system and use clean lubricant
Losses or alteration of the colour of the lubricant	Lubricant in excess	To reduce the quantity, to select a crease more consistency
		To substitute the bearing or the lubricant
		To clean the housing and the contiguous part

MICRO RODAMIENTOS RÍGIDOS DE BOLAS MINIATURE RADIAL BALL BEARINGS

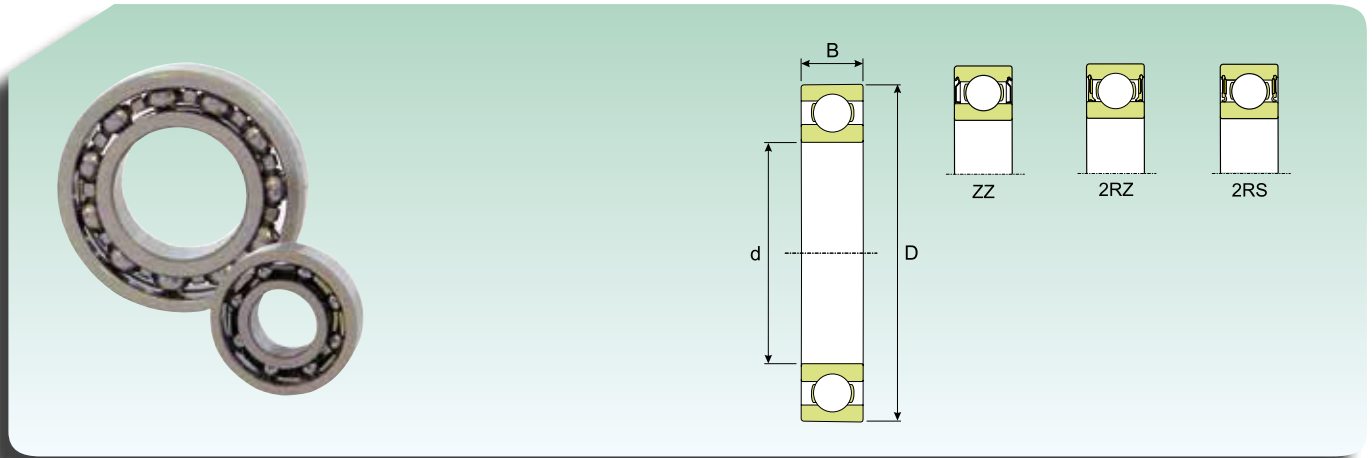

Dimensiones (mm) Dimension (mm)			Coeficiente de carga (KN) Load rating (KN)		Velocidad límite (rpm) Speed limit (Rpm)		Peso (Kg) Weight (Kg)	Sigla Designation
d (mm)	D (mm)	B (mm)	Dinámico Dynamic C	Estático Static C ₀	Grasa Grease	Aceite Oil		
					3	10	4	0.488
4	13	5	1.310	0.490	42 000	50 000	0,0031	624
4	16	5	1.110	0.380	43 000	50 000	0,0054	634
5	16	5	1.760	0.680	37 000	44 000	0,0050	625
5	19	6	2.340	0.950	34 000	42 000	0,0090	635
6	19	6	2.340	0.950	34 000	41 000	0,0084	626
7	19	6	2.340	0.950	35 000	42 000	0,0075	607
7	22	7	3.450	1.400	32 000	37 000	0,0130	627
8	22	7	3.450	1.400	32 000	38 000	0,0120	608
9	24	7	3.900	1.660	31 000	37 000	0,0140	609
9	26	8	4.750	1.960	27 000	32 000	0,0200	629

RODAMIENTOS RÍGIDOS DE UNA HILERA DE BOLAS RADIAL DEEP GROOVE BALL BEARINGS SINGLE ROW

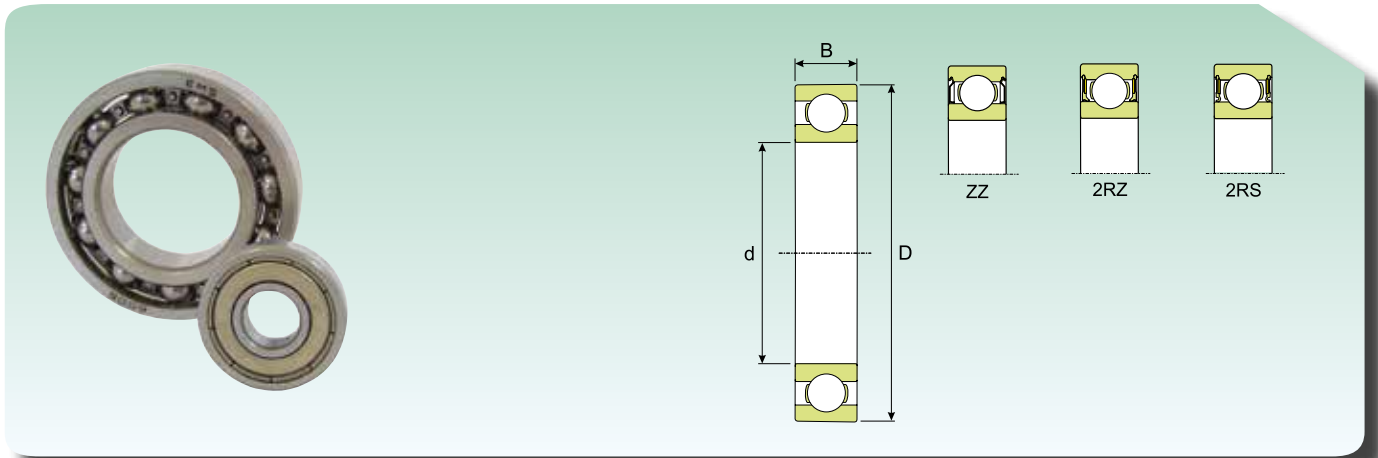

Dimensiones (mm) Dimension (mm)			Coeficiente de carga (KN) Load rating (KN)		Velocidad límite (rpm) Speed limit (Rpm)		Peso (Kg) Weight (Kg)	Sigla Designation
d (mm)	D (mm)	B (mm)	Dinámico Dynamic C	Estático Static C ₀	Grasa Grease	Aceite Oil		
					10	26	8	4.750
12	28	8	5.400	2.360	29 000	33 000	0,022	6001
15	32	9	5.850	2.850	25 000	29 000	0,030	6002
17	35	10	6.800	3.350	23 000	26 000	0,039	6003
20	42	12	9.950	5.050	18 000	21 000	0,069	6004
25	47	12	11.900	6.550	16 000	19 000	0,080	6005
30	55	13	13.800	8.300	13 000	15 000	0,120	6006
35	62	14	16.800	10.300	12 000	14 000	0,160	6007
40	68	15	17.800	11.600	10 000	12 000	0,190	6008
45	75	16	22.100	15.100	9 200	11 000	0,250	6009
50	80	16	22.900	16.600	8 400	9 800	0,260	6010
55	90	18	29.600	21.200	7 700	9 000	0,390	6011
60	95	18	30.700	23.200	7 100	8 300	0,420	6012
65	100	18	31.900	25.000	6 700	8 000	0,440	6013
70	110	20	39.700	31.000	6 300	7 100	0,600	6014
75	115	20	41.600	33.500	5 800	7 000	0,640	6015
80	125	22	49.400	40.000	5 500	6 500	0,850	6016
85	130	22	52.000	43.000	5 300	6 300	0,890	6017
90	140	24	60.500	50.000	5 000	6 000	1,150	6018
95	145	24	63.700	54.000	4 700	5 500	1,200	6019
100	150	24	63.700	54.000	4 500	5 500	1,250	6020
105	160	26	76.100	65.500	4 200	5 000	1,600	6021
110	170	28	85.200	73.500	4 000	4 700	1,950	6022
120	180	28	88.400	80.000	3 800	4 500	2,050	6024

RODAMIENTOS RÍGIDOS DE UNA HILERA DE BOLAS RADIAL DEEP GROOVE BALL BEARINGS SINGLE ROW

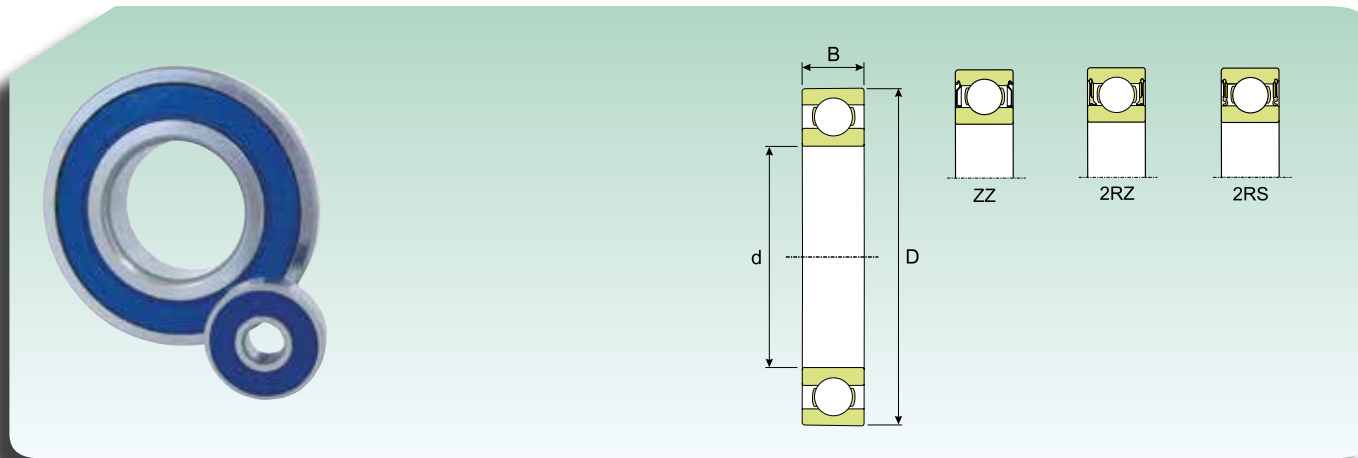

Dimensiones (mm) Dimension (mm)			Coeficiente de carga (KN) Load rating (KN)		Velocidad límite (rpm) Speed limit (Rpm)		Peso (Kg) Weight (Kg)	Sigla Designation
d (mm)	D (mm)	B (mm)	Dinámico Dynamic C	Estático Static C ₀	Grasa Grease	Aceite Oil		
					10	30	9	5.400
12	32	10	7.280	3.100	23 000	28 000	0,037	6201
15	35	11	8.060	3.750	20 000	25 000	0,045	6202
17	40	12	9.950	4.750	18 000	22 000	0,065	6203
20	47	14	13.500	6.650	16 000	18 000	0,110	6204
25	52	15	14.800	7.850	13 000	16 000	0,130	6205
30	62	16	20.300	11.300	12 000	14 000	0,200	6206
35	72	17	27.000	15.300	10 000	12 000	0,290	6207
40	80	18	32.500	19.000	8 800	10 000	0,370	6208
45	85	19	35.100	21.600	7 800	9 200	0,410	6209
50	90	20	37.100	23.200	7 100	8 300	0,460	6210
55	100	21	46.200	29.200	6 400	7 600	0,610	6211
60	110	22	55.300	36.000	6 000	7 300	0,780	6212
65	120	23	58.500	40.500	5 500	7 000	0,990	6213
70	125	24	63.700	45.000	5 100	6 100	1,050	6214
75	130	25	68.900	49.000	4 800	5 600	1,200	6215
80	140	26	72.800	55.000	4 500	5 300	1,400	6216
85	150	28	87.100	64.000	4 300	5 000	1,800	6217
90	160	30	101.000	73.500	4 000	4 800	2,150	6218
95	170	32	114.000	82.000	3 800	4 500	2,600	6219
100	180	34	127.000	93.000	3 600	4 300	3,150	6220
105	190	36	146.000	105.000	3 400	4 000	3,700	6221
110	200	38	151.000	118.000	3 200	3 800	4,350	6222

RODAMIENTOS RÍGIDOS DE UNA HILERA DE BOLAS RADIAL DEEP GROOVE BALL BEARINGS SINGLE ROW

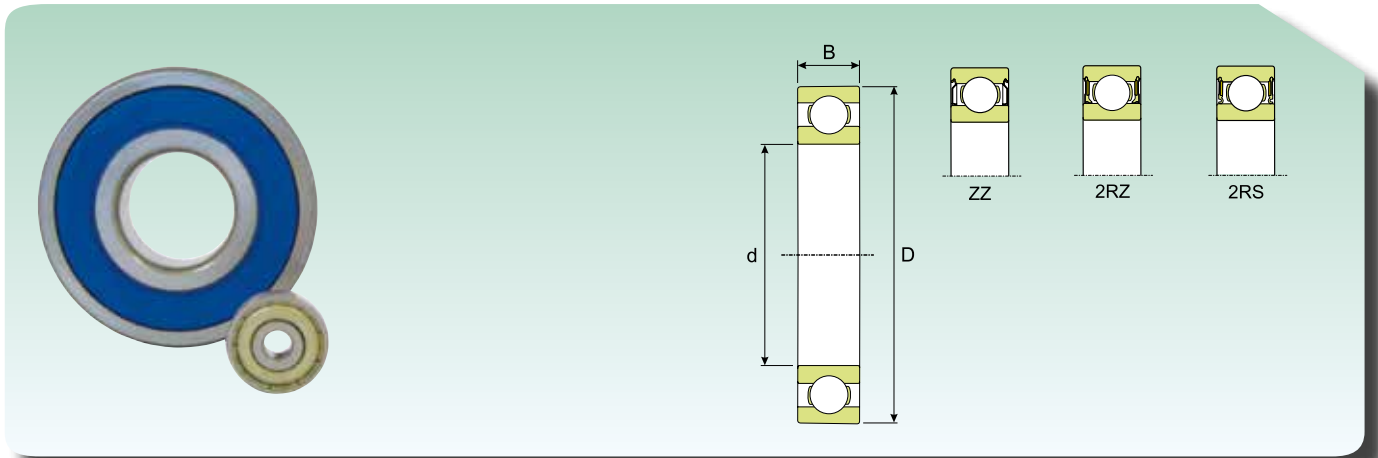

Dimensiones (mm) Dimension (mm)			Coeficiente de carga (KN) Load rating (KN)		Velocidad límite (rpm) Speed limit (Rpm)		Peso (Kg) Weight (Kg)	Sigla Designation
d (mm)	D (mm)	B (mm)	Dinámico Dynamic C	Estático Static C ₀	Grasa Grease	Aceite Oil		
					10	35	11	8.520
12	37	12	10.100	4.200	21 000	25 000	0,060	6301
15	42	13	11.900	5.450	19 000	22 000	0,082	6302
17	47	14	14.300	6.550	16 000	19 000	0,120	6303
20	52	15	16.800	7.900	14 000	17 500	0,140	6304
25	62	17	23.400	11.600	12 000	14 000	0,230	6305
30	72	19	29.600	16.000	10 000	12 000	0,350	6306
35	80	21	35.100	19.100	8 800	10 000	0,460	6307
40	90	23	42.300	24.000	7 800	9 200	0,630	6308
45	100	25	55.300	32.000	7 000	8 200	0,830	6309
50	110	27	65.000	38.500	6 400	7 500	1,050	6310
55	120	29	74.100	45.000	5 800	6 800	1,350	6311
60	130	31	85.200	52.000	5 400	6 300	1,700	6312
65	140	33	97.500	60.000	5 000	6 000	2,100	6313
70	150	35	111.000	68.000	4 500	5 300	2,500	6314
75	160	37	119.000	76.500	4 300	5 000	3,000	6315
80	170	39	130.000	86.500	4 000	4 800	3,600	6316
85	180	41	133.000	97.000	3 800	4 500	4,250	6317
90	190	43	151.000	108.000	3 600	4 300	4,900	6318
95	200	45	159.000	119.000	3 300	3 900	5,650	6319
100	215	47	174.000	140.000	3 200	3 700	7,000	6320

RODAMIENTOS RÍGIDOS DE UNA HILERA DE BOLAS RADIAL BALL BEARINGS SINGLE ROW

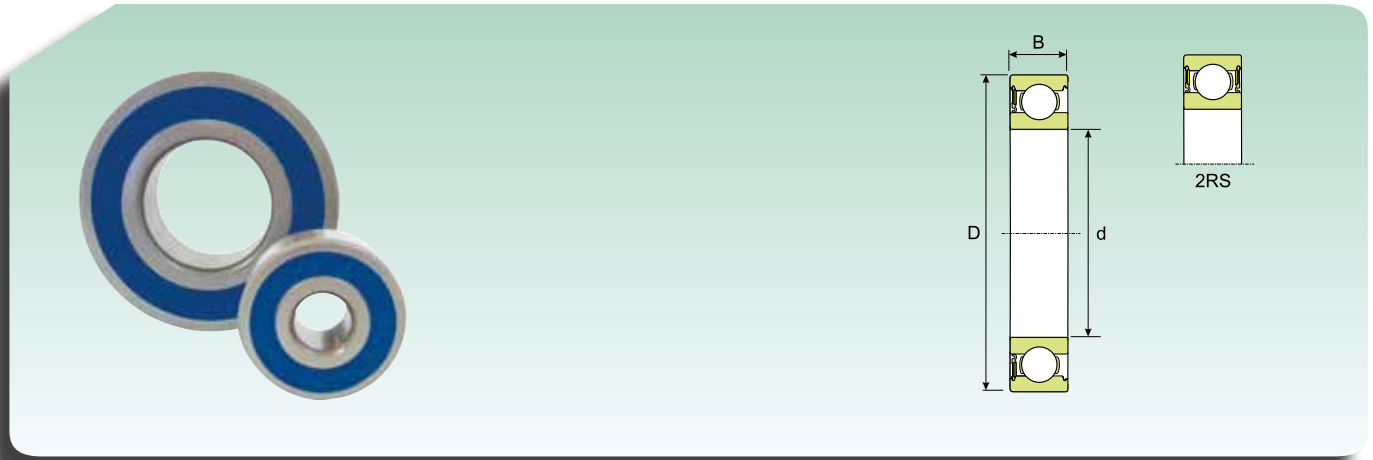

Dimensiones (mm) Dimension (mm)			Coeficiente de carga (KN) Load rating (KN)		Velocidad límite (rpm) Speed limit (Rpm)		Peso (Kg) Weight (Kg)	Sigla Designation
d (mm)	D (mm)	B (mm)	Dinámico Dynamic C	Estático Static C ₀	Grasa Grease	Aceite Oil		
					10	30	14	5.070
12	32	14	6.890	3.100	13 000	15 000	0,045	62201
15	35	14	7.800	3.750	11 000	13 000	0,054	62202
17	40	16	9.560	4.750	10 000	12 000	0,083	62203
20	47	18	12.700	6.550	9 000	10 000	0,130	62204
25	52	18	14.000	7.800	7 000	8 500	0,150	62205
30	62	20	19.500	11.200	6 000	7 500	0,240	62206
35	72	23	25.500	15.300	5 500	6 300	0,370	62207
40	80	23	30.700	19.000	4 500	5 600	0,440	62208
45	85	23	33.200	21.600	4 300	5 000	0,480	62209
50	90	23	35.100	23.200	4 000	4 800	0,520	62210

RODAMIENTOS RÍGIDOS DE UNA HILERA DE BOLAS RADIAL BALL BEARINGS SINGLE ROW



Dimensiones (mm) Dimension (mm)			Coeficiente de carga (KN) Load rating (KN)		Velocidad límite (rpm) Speed limit (Rpm)	Peso (Kg) Weight (Kg)	Sigla Designation
d (mm)	D (mm)	B (mm)	Dinámico Dynamic C	Estático Static C ₀			
8	22	11	3.250	1.370	20 000	0,016	630/8
10	26	12	4.620	1.960	19 000	0,025	63000
12	28	12	5.070	2.360	17 000	0,029	63001
15	32	13	5.590	2.850	14 000	0,039	63002
17	35	14	6.050	3.250	13 000	0,052	63003
20	42	16	9.360	5.000	11 000	0,086	63004
25	47	16	11.200	6.550	9 500	0,100	63005
30	55	19	13.300	8.300	8 000	0,160	63006
35	62	20	15.900	10.200	7 000	0,210	63007
40	68	21	16.800	11.600	6 300	0,260	63008
45	75	23	20.800	14.600	5 600	0,340	63009
50	80	23	21.600	16.000	5 000	0,370	63010

RODAMIENTOS RÍGIDOS DE UNA HILERA DE BOLAS RADIAL DEEP GROOVE BALL BEARINGS SINGLE ROW

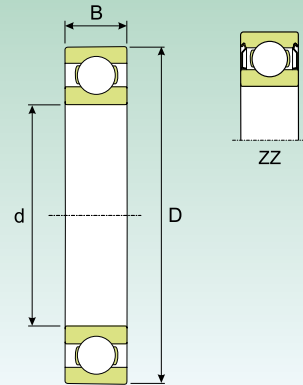

Dimensiones (mm) Dimension (mm)			Coeficiente de carga (KN) Load rating (KN)		Velocidad límite (rpm) Speed limit (Rpm)		Peso (Kg) Weight (Kg)	Sigla Designation
d (mm)	D (mm)	B (mm)	Dinámico Dynamic C	Estático Static C ₀	Grasa Grease	Aceite Oil		
					15	32	8	5.850
17	35	8	6.800	3.350	20 000	24 000	0,032	16003*
20	42	8	7.900	4.500	18 000	21 000	0,050	16004
25	47	8	8.350	5.100	15 000	18 000	0,060	16005
30	55	9	11.900	7.400	13 000	15 000	0,085	16006
35	62	9	13.000	8.200	12 000	14 000	0,110	16007
40	68	9	13.800	9.650	10 00	12 000	0,130	16008
45	75	10	16.500	10.800	9 200	11 000	0,170	16009
50	80	10	16.800	11.400	8 500	10 000	0,180	16010
55	90	11	20.300	15.300	7 700	9 000	0,260	16011
60	95	11	20.800	17.500	7 100	8 500	0,280	16012
65	100	11	22.100	16.300	6 885	8 100	0,300	16013
70	110	13	28.600	24.500	6 120	7 200	0,430	16014
75	115	13	29.600	26.500	5 738	6 750	0,460	16015
80	125	14	34.400	30.900	5 355	6 300	0,600	16016
85	130	14	35.100	32.900	5 126	6 030	0,630	16017
90	140	16	42.800	38.300	4 820	5 670	0,850	16018
95	145	16	43.900	40.700	4 590	5 400	0,890	16019
100	150	16	45.300	43.200	4 284	5 040	0,910	16020
10	28	8	4.620	1.960	28 000	34 000	0,022	16100*
12	30	8	5.070	2.360	26 000	32 000	0,023	16101

* Sólo en ejecución ZZ
ZZ type only

RODAMIENTOS RÍGIDOS DE UNA HILERA DE BOLAS RADIAL DEEP GROOVE BALL BEARINGS SINGLE ROW

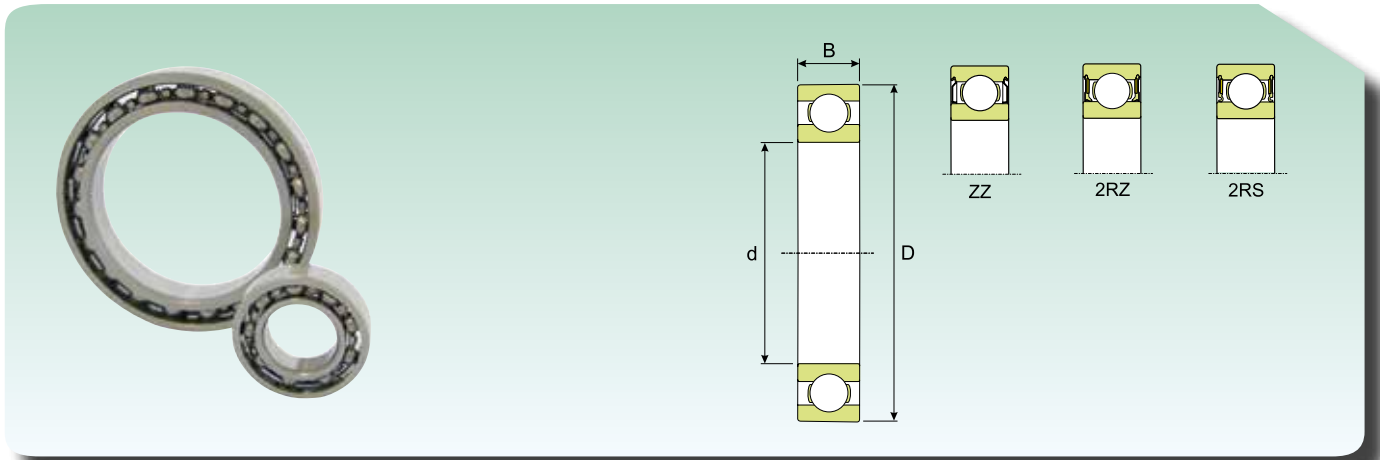

Dimensiones (mm) Dimension (mm)			Coeficiente de carga (KN) Load rating (KN)		Velocidad límite (rpm) Speed limit (Rpm)		Peso (Kg) Weight (Kg)	Sigla Designation
d (mm)	D (mm)	B (mm)	Dinámico Dynamic C	Estático Static C ₀	Grasa Grease	Aceite Oil		
					10	19	5	1.380
12	21	5	1.430	0.670	32 000	38 000	0,0063	61801
15	24	5	1.560	0.800	28 000	34 000	0,0074	61802
17	26	5	1.680	0.930	24 000	30 000	0,0082	61803
20	32	7	2.700	1.500	19 000	24 000	0,0180	61804
25	37	7	4.360	2.600	17 000	20 000	0,0220	61805
30	42	7	4.490	2.900	15 000	18 000	0,0270	61806
35	47	7	4.750	3.200	13 000	16 000	0,0300	61807
40	52	7	4.940	3.450	11 000	14 000	0,0340	61808
45	58	7	6.500	6.000	10 710	12 600	0,040	61809
50	65	7	6.800	6.700	9 945	11 700	0,052	61810
55	72	9	8.860	8.700	9 180	10 800	0,083	61811
60	78	10	11.700	11.200	8 415	9 900	0,110	61812
65	85	10	12.200	12.500	7 650	9 000	0,130	61813
70	90	10	12.200	13.000	6 885	8 100	0,140	61814
75	95	10	12.500	14.100	6 503	7 650	0,150	61815
80	100	10	12.800	14 800	6 120	7 200	0,150	61816
85	110	13	19.200	20.400	5 738	6 750	0,270	61817
90	115	13	19.200	21.600	5 355	6 300	0,280	61818
95	120	13	19.600	22.400	5 126	6 030	0,300	61819
100	125	13	19.600	23.600	4 820	5 670	0,310	61820
105	130	13	20.400	19.300	4 820	5 670	0,320	61821
110	140	16	27.600	25.500	4 284	5 040	0,600	61822
120	150	16	28.600	27.600	4 055	4 770	0,650	61824
130	165	18	36.900	42.200	3 672	4 320	0,930	61826
140	175	18	38.300	45.600	3 443	4 050	0,990	61828
150	190	20	47.900	59.800	3 290	3 870	1,400	61830

RODAMIENTOS RÍGIDOS DE UNA HILERA DE BOLAS RADIAL DEEP GROOVE BALL BEARINGS SINGLE ROW

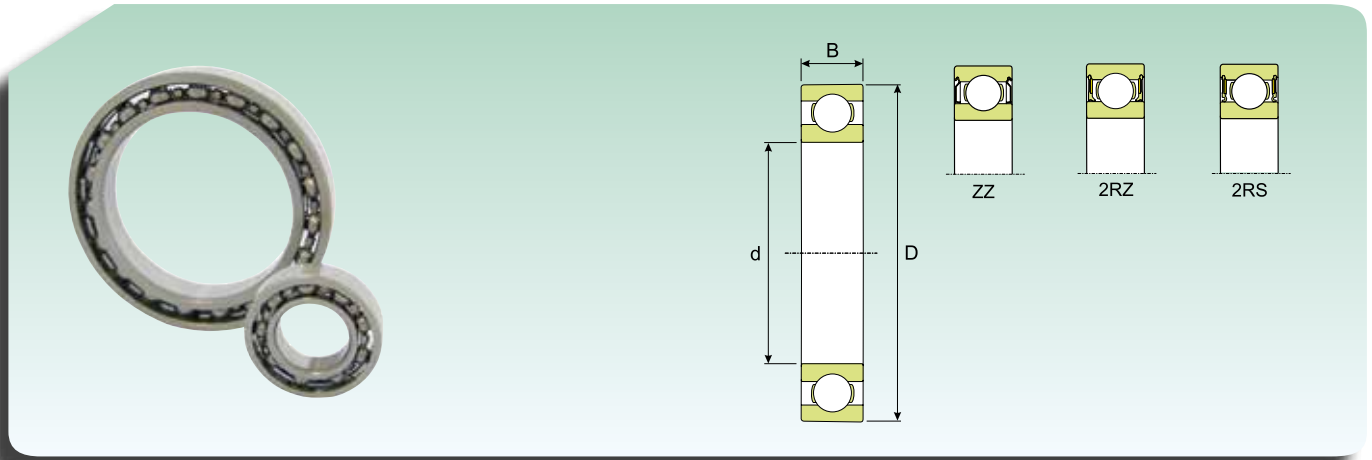

Dimensiones (mm) Dimension (mm)			Coeficiente de carga (KN) Load rating (KN)		Velocidad límite (rpm) Speed limit (Rpm)		Peso (Kg) Weight (Kg)	Sigla Designation
d (mm)	D (mm)	B (mm)	Dinámico Dynamic C	Estático Static C ₀	Grasa Grease	Aceite Oil		
					10	22	6	1.950
12	24	6	2.250	0.980	30 000	36 000	0,011	61901
15	28	7	4.030	2.040	24 000	30 000	0,016	61902
17	30	7	4.360	2.320	22 000	28 000	0,018	61903
20	37	9	6.370	3.650	18 000	22 000	0,038	61904
25	42	9	6.630	4.000	16 000	19 000	0,045	61905
30	47	9	7.280	4.550	14 000	17 000	0,051	61906
35	55	10	9.560	6.200	11 000	14 000	0,080	61907
40	62	12	13.800	9.300	10 000	13 000	0,120	61908
45	68	12	13.800	10.600	9 945	11 700	0,140	61909
50	72	12	14.400	11.600	9 180	10 800	0,140	61910
55	80	13	16.200	13.800	8 415	9 900	0,190	61911
60	85	13	16.200	14.100	7 650	9 000	0,200	61912
65	90	13	17.100	15.700	7 268	8 550	0,220	61913
70	100	16	23.400	20.800	6 503	7 650	0,350	61914
75	105	16	23.800	19.000	6 120	7 200	0,370	61915
80	110	16	24.600	20.000	5 738	6 750	0,400	61916
85	120	18	31.300	29.500	5 355	6 300	0,550	61917
90	125	18	32.600	30.900	5 126	6 030	0,590	61918
95	130	18	33.200	32.900	4 820	5 670	0,610	61919
100	140	20	41.500	40.200	4 590	5 400	0,830	61920
105	145	20	43.400	43.200	4 284	5 040	0,870	61921
110	150	20	42.800	44.200	4 284	5 040	0,900	61922
120	165	22	54.200	55.900	3 825	4 500	1,200	61924
130	180	24	63.700	65.700	3 443	4 050	1,850	61926

RODAMIENTOS DE UNA HILERA DE BOLAS CON CONTACTO ANGULAR (JAULA DE POLIAMIDA)
ANGULAR CONTACT SINGLE-ROW BALL BEARINGS (POLYAMIDE CAGE)

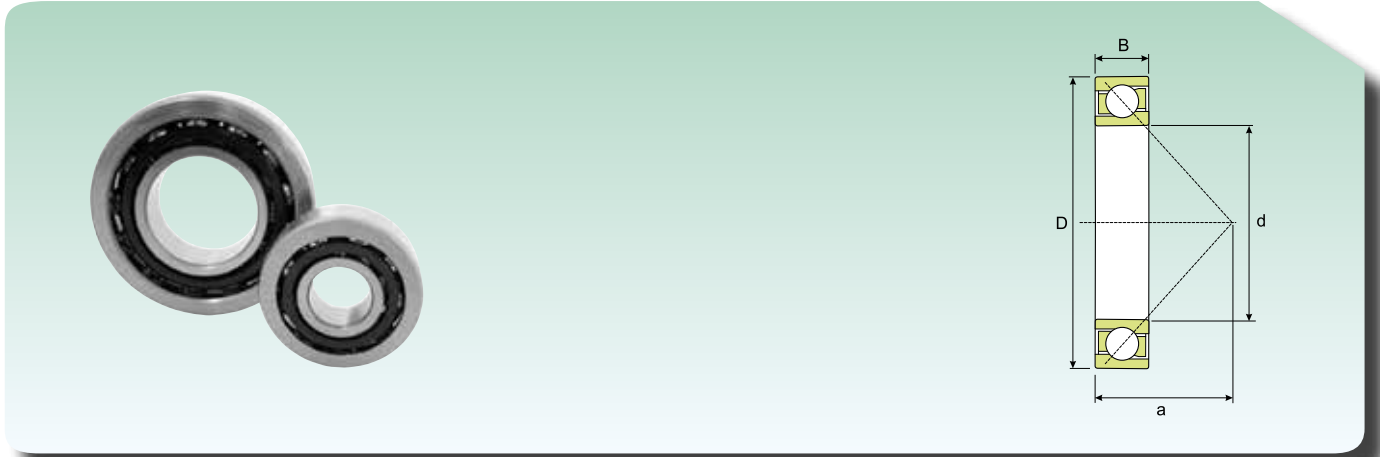

Dimensiones (mm) Dimension (mm)			Coeficiente de carga (KN) Load rating (KN)		Velocidad límite (rpm) Speed limit (Rpm)		Peso (Kg) Weight (Kg)	Sigla Designation
d (mm)	D (mm)	B (mm)	Dinámico Dynamic C	Estático Static C ₀	Grasa Grease	Aceite Oil		
					10	30	9	7.020
12	32	10	7.610	3.800	18 000	26 000	0,036	7201
15	35	11	8.840	4.800	17 000	24 000	0,045	7202
17	40	12	11.100	6.100	15 000	20 000	0,065	7203
20	47	14	14.000	8.300	12 000	17 000	0,110	7204
25	52	15	15.600	10.200	10 000	15 000	0,130	7205
30	62	16	23.800	15.600	8 500	12 000	0,200	7206
35	72	17	30.700	20.800	8 000	11 000	0,280	7207
40	80	18	36.400	26.000	7 000	9 500	0,370	7208
45	85	19	37.700	28.000	6 700	9 000	0,420	7209
50	90	20	39.000	30.500	6 000	8 000	0,470	7210
55	100	21	48.800	38.000	5 600	7 500	0,620	7211
60	110	22	57.200	45.500	5 000	6 700	0,800	7212
12	37	12	10.600	5.000	17 000	24 000	0,060	7301
15	42	13	13.000	6.700	15 000	20 000	0,080	7302
17	47	14	15.900	8.300	13 000	18 000	0,110	7303
20	52	15	19.000	10.400	11 000	16 000	0,140	7304
25	62	17	26.000	15.600	9 000	13 000	0,230	7305
30	72	19	34.500	21.200	8 000	11 000	0,340	7306
35	80	21	39.000	24.500	7 500	10 000	0,450	7307
40	90	23	49.400	33.500	6 700	9 000	0,630	7308
45	100	25	60.500	41.500	6 000	8 000	0,850	7309
50	110	27	74.100	51.000	5 300	7 000	1,100	7310
55	120	29	85.200	60.000	4 800	6 300	1,400	7311
60	130	31	95.600	69.500	4 500	6 000	1,750	7312

Bajo demanda disponible con jaula de acero - Under request available with steel cage

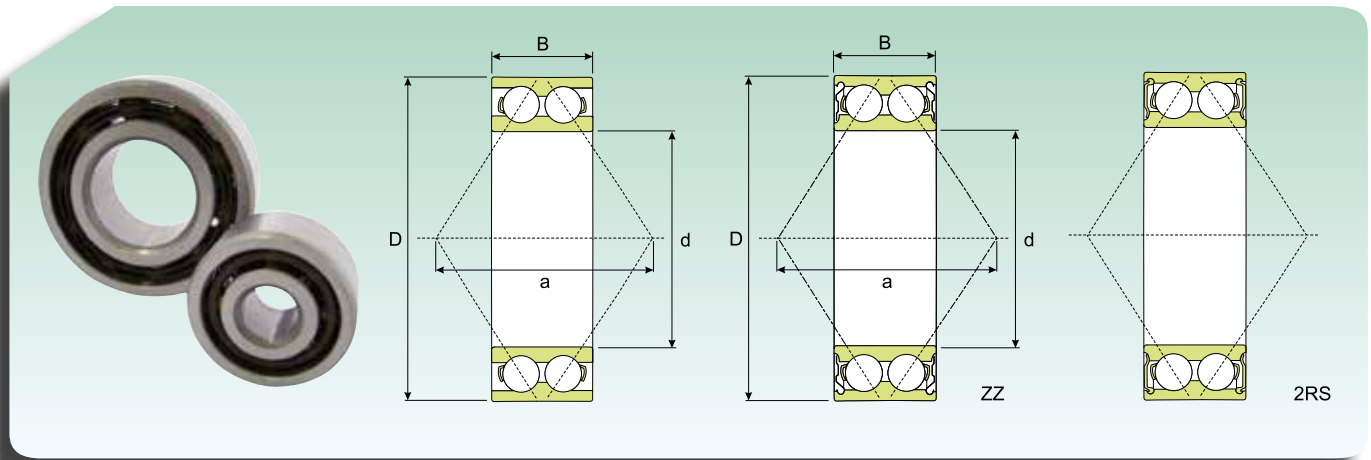
**RODAMIENTOS DE DOS HILERAS DE BOLAS CON CONTACTO ANGULAR (JAULA DE POLIAMIDA)
ANGULAR CONTACT BALL BEARINGS DOUBLE ROW (POLYAMIDE CAGE)**

Dimensiones (mm) Dimension (mm)			Coeficiente de carga (KN) Load rating (KN)		Velocidad límite (rpm) Speed limit (Rpm)		Peso (Kg) Weight (Kg)	Sigla Designation
d (mm)	D (mm)	B (mm)	Dinámico Dynamic C	Estático Static C ₀	Grasa Grease	Aceite Oil		
10	30	14,0	7.410	4.300	16 000	22 000	0,051	3200
12	32	15,9	10.100	5.600	15 000	20 000	0,058	3201
15	35	15,9	11.200	6.800	12 000	17 000	0,066	3202
17	40	17,5	14.000	8.650	10 000	15 000	0,096	3203
20	47	20,6	18.600	12.000	9 000	13 000	0,160	3204
25	52	20,6	20.300	14.000	8 000	11 000	0,180	3205
30	62	23,8	28.100	20.000	7 000	9 500	0,290	3206
35	72	27,0	37.100	27.500	6 000	8 000	0,440	3207
40	80	30,2	44.900	33.500	5 600	7 500	0,580	3208
45	85	30,2	47.500	38.000	5 000	6 700	0,630	3209
50	90	30,2	47.500	39.000	4 800	6 300	0,660	3210
55	100	33,3	57.200	67.000	4 300	5 600	1,050	3211
60	110	36,5	72.100	85.000	3 800	5 000	1,400	3212
15	42	19,0	15.100	9.150	10 000	15 000	0,130	3302
17	47	22,2	21.200	12.500	9 500	14 000	0,180	3303
20	52	22,2	22.100	14.300	8 500	12 000	0,220	3304
25	62	25,4	31.200	20.800	7 500	10 000	0,350	3305
30	72	30,2	41.000	28.500	6 300	8 500	0,530	3306
35	80	34,9	48.800	34.000	5 600	7 500	0,730	3307
40	90	36,5	59.200	43.000	5 000	6 700	0,950	3308
45	100	39,7	72.100	73.500	4 500	6 000	1,400	3309
50	110	44,4	88.000	96.500	4 000	5 300	1,950	3310
55	120	49,2	95.200	108.000	3 800	5 000	2,550	3311
60	130	54,0	112.000	127.000	3 400	4 500	3,250	3312

Bajo demanda disponible con jaula de acero - Under request available with steel cage



Manguitos y accesorios

Sleeves and accessories



MANGUITOS Y ACCESORIOS

SLEEVES AND ACCESSORIES

MANGUITOS DE FIJACIÓN

Utilizados para el bloqueo de los rodamientos con agujero cónico en los ejes cilíndricos (**Fig. 1**), tienen forma cónica y están cortados longitudinalmente para adaptarse mejor a las dimensiones del agujero de los rodamientos (conicidad 1:12).

ADAPTER SLEEVES

Adapter sleeves are used to lock bearings with tapered bore on cylindrical shafts (**Fig. 1**), they have a tapered stem shape and are cut lengthwise to adapt to the dimensions of the bearing's bore (taper 1:12).

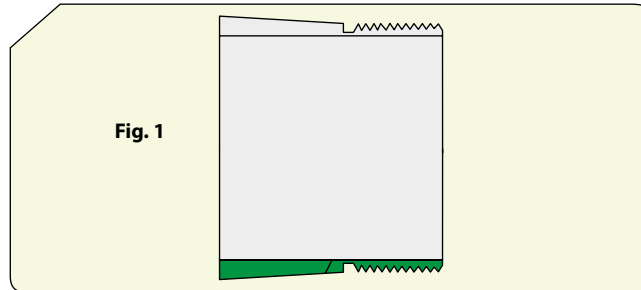

Se suministran con tuercas y arandelas (**Fig. 2**), son los más comunes y utilizados; simplifican el montaje y el desmontaje de los rodamientos y el diseño de las máquinas. Permiten tolerancias más holgadas entre eje y rodamiento.

They are supplied complete with lock nuts and washers (**Fig. 2**) are the most common type used and simplify the assembly and disassembly of the bearings and the design of the machines. They allow for greater tolerances between shaft and bearing.

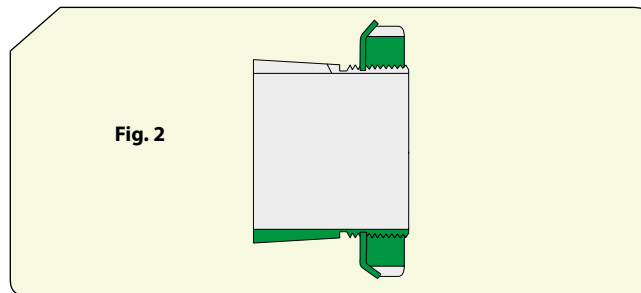

MANGUITOS DE DESMONTAJE

Utilizados para el bloqueo de los rodamientos con agujero cónico en los ejes cilíndricos (**Fig. 3**), tienen forma cónica y están cortados longitudinalmente para adaptarse mejor a las dimensiones del agujero de los rodamientos (conicidad 1:12).

WITHDRAWAL SLEEVES

They are used to lock bearings with tapered bore on cylindrical shafts (**Fig. 3**), they have a tapered stem shape and are cut lengthwise to adapt to the dimensions of the bearings' bore (taper 1:12).

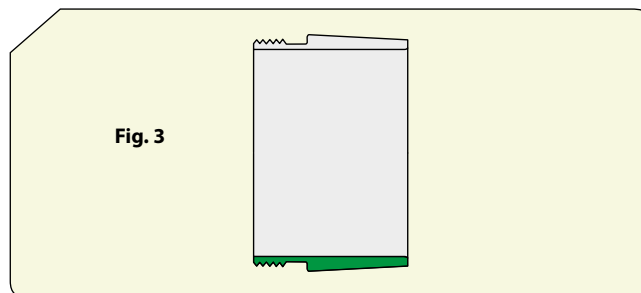

Son menos comunes porque son más difíciles de montar, no se suministran con tuercas de desmontaje (**Fig. 4**).

They are less popular because they are more difficult to assemble, are not supplied complete with disassembly lock nuts (**Fig. 4**).

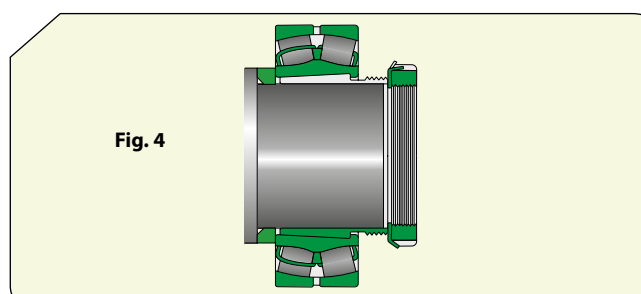

Los rodamientos montados en manguitos de desmontaje se deberán apoyar en un apoyo fijo en el eje, el manguito se inserta luego y se prensa dentro del agujero cónico del rodamiento.

TUERCAS

ISB® suministra diversos tipos de tuercas: de bloqueo o de extracción, en base a su utilización. Dos son los empleos que pueden tener estos accesorios para rodamientos: uno el bloqueo en el eje, que puede verificarse en diferentes modos, el otro, es facilitar el montaje/desmontaje del rodamiento del eje. Las tuercas ISB® ofrecen tres modos de bloqueo en el eje, como se expone aquí abajo.

ARANDELA DE SEGURIDAD

Se utilizan con las series de tuercas KM y KML. Son elementos de bloqueo simples, estables y fiables (Fig. 5).

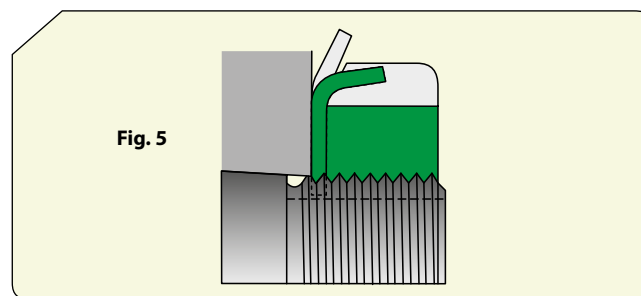

Bearings fitted on withdrawal sleeves must rest against a fixed shoulder on the shaft and the sleeve is fitted subsequently and pressed into the tapered bore of the bearing.

LOCK NUTS

ISB® supplies different types of locking or extraction lock nuts based on what they are to be used for. These accessories for bearings may have two uses: one for locking on the shaft, which may be done differently and one for facilitating assembly/disassembly of the bearing on/from the shaft. ISB® lock nuts offer three different ways of locking on the shaft, as follows.

LOCKING SAFETY WASHER

They are used with lock nut series KM and KML. They are simple, stable and reliable locking elements (Fig. 5).

GRAPA DE BLOQUEO O PLACA

Se ensambla en la tuerca, tipo HM, gracias a un tornillo que fija la placa insertada en una ranura de la arandela y un ranurado en el eje. Designación MS (Fig. 6).

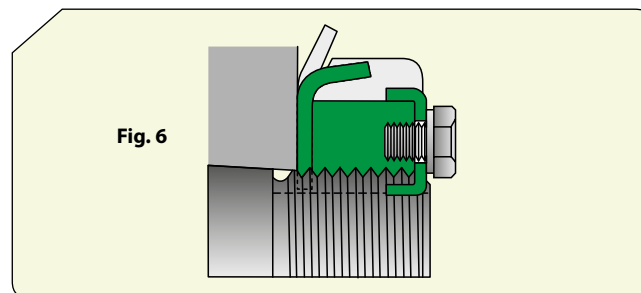

LOCKING CLIP OR PLATE

Are assembled into the lock nuts, HM type, by a screw that fix a plate in a slot in the nut and into a groove on the shaft. Designation MS (Fig. 6).

TUERCA AUTOBLOQUEANTE

La tuerca cuenta con un anillo interior de nylon que en el enroscado genera fricción, a contacto con el roscado macho, generando una fuerza bloqueante. Las tuercas autobloqueantes tienen como prefijo la designación GTN y GTP (Fig. 7).

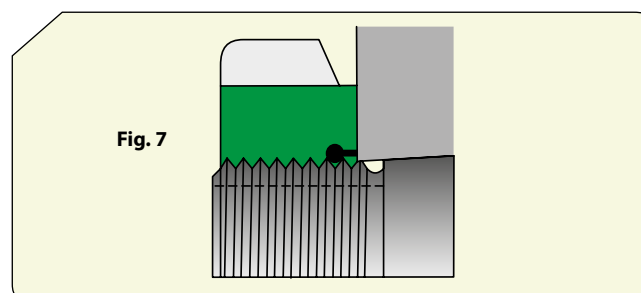

SELF-LOCKING NUT

The lock nut has an internal Nylon ring that generates friction whilst screwing it, in contact with the male thread, generating a locking force. The self-locking nuts have GTN and GTP designation suffix (Fig. 7).

TUERCAS DE PRECISIÓN

El montaje de tornillos de bolas o rodamientos generalmente con tuercas tradicionales, a causa de la perpendicularidad entre roscados y superficies de tope, genera problemas de precisión. **ISB®** ha desarrollado series de tuercas con características de tolerancia de precisión, de perpendicularidad entre roscados y plano frontal y de tolerancias de los roscados, que resuelven estos problemas en modo definitivo.

PRECISION LOCK NUTS

The assembly of ball screws or bearings usually with conventional locknuts, due to the perpendicularity between the threads and the contact surfaces, generates precision problems. **ISB®** has developed some series of locknuts with characteristics of precision tolerance, perpendicularity between threads and front surface and tolerance of the threads that resolve these problems once and for all.

TUERCAS YSF BLOQUEO LATERAL

El sistema de bloqueo está dado por 3 pasadores de fijación equidistantes e inclinados 30° (**Fig. 8**).

- Perpendicularidad entre roscado y plano frontal: 0,002 mm
- Material: SCM4
- Dureza: HRC 28 – 32
- Tolerancia del roscado: ISO 4H

YSF LOCK NUTS FOR SIDE LOCKING

The locking system has 3 equally distant locking grub screws, set at an angle of 30° (**Fig. 8**).

- Perpendicularity between thread and front surface: 0.002 mm
- Material: SCM4
- Hardness: HRC 28 – 32
- Thread tolerance: ISO 4H

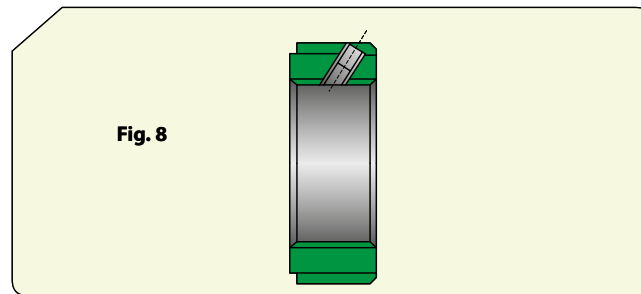

TUERCAS YSA BLOQUEO AXIAL

El sistema de bloqueo está dado por 3 pasadores de fijación equidistantes. La utilización de este tipo de tuercas está indicada para espacios reducidos de montaje (**Fig. 9**).

- Perpendicularidad entre roscado y plano frontal: 0,002 mm
- Material: SCM4
- Dureza: HRC 28 – 32
- Tolerancia del roscado: ISO 4H

YSA LOCK NUTS FOR AXIAL LOCKING

The locking system has three equally distant locking grub screws. This type of lock nut is suitable for tight assembly spaces (**Fig. 9**).

- Perpendicularity between thread and front surface: 0.002 mm
- Material: SCM4
- Hardness: HRC 28 – 32
- Thread tolerance: ISO 4H

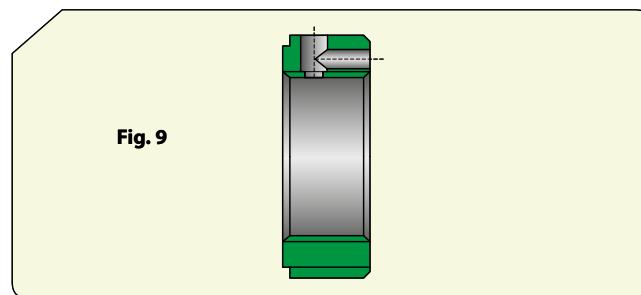

TUERCAS YSR BLOQUEO RADIAL

El sistema de bloqueo radial está dado por 3 pasadores de fijación equidistantes. Este tipo de tuerca tiene un ancho reducido y está indicada para montajes con reducidas anchuras de roscado (**Fig. 10**).

- Perpendicularidad entre roscado y plano frontal: 0.002 mm
- Material: SCM4
- Dureza: HRC 28 – 32
- Tolerancia del roscado: ISO 4H

YSR LOCK NUTS FOR RADIAL LOCKING

*This radial locking system has three equally distant locking grub screws. This type of lock nut is not as wide and it suitable for assembly on restricted thread width (**Fig. 10**).*

- *Perpendicularity between thread and front surface: 0.002 mm*
- *Material: SCM4*
- *Hardness: HRC 28 – 32*
- *Thread tolerance: ISO 4H*

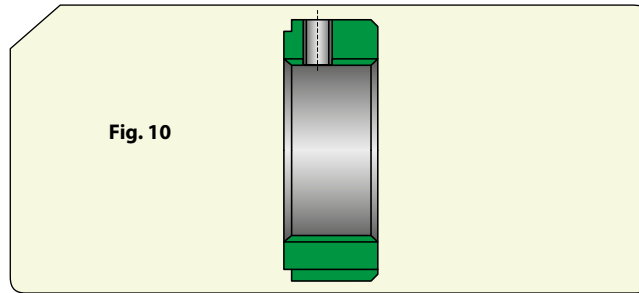

TUERCAS YSK BLOQUEO CON RANURADO ELÁSTICO

El sistema de bloqueo está dado por el ranurado y por la elasticidad del acero; ajustando los tornillos de fijación, el rozamiento generado permite el bloqueo. Indicada para empleos pesados, gracias a su capacidad de bloqueo, tolerancias menos precisas y facilidad de montaje (**Fig. 11**).

- Perpendicularidad entre roscado y plano frontal: 0,01 mm
- Material: SCM4
- Dureza: HRC 26 – 30
- Tolerancia del roscado: ISO 6H

YSK LOCK NUTS WITH ELASTIC SLOT

*The locking system is obtained by the slot and the elasticity of the steel material; when you tighten the locking screws, they are locked by the friction generated. They are suitable for heavy-duty usage thanks to the locking capacity, less precise tolerances and ease of assembly (**Fig. 11**).*

- *Perpendicularity between thread and front surface: 0.01 mm*
- *Material: SCM4*
- *Hardness: HRC 26 – 30*
- *Thread tolerance: ISO 6H*

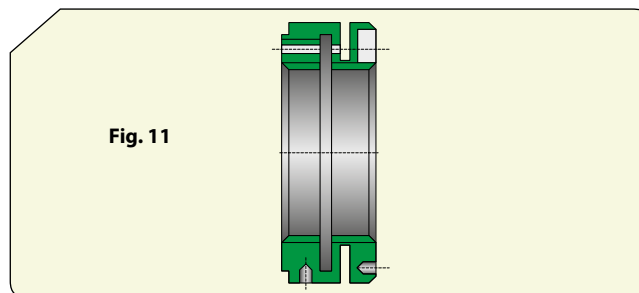

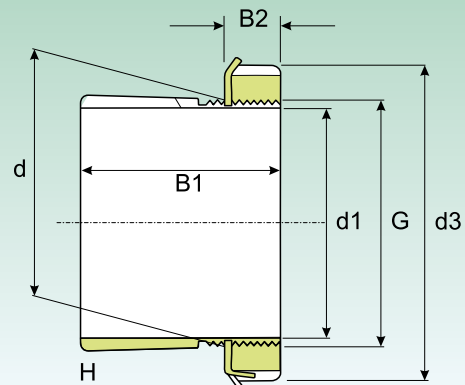
**MANGUITOS DE FIJACIÓN
ADAPTER SLEEVES**

Dimensión Dimension						Peso (kg) Weight (Kg)	Sigla Designation			
d1 (mm)	d (mm)	d3 (mm)	B1 (mm)	B2 (mm)	G (mm)		Manguitos de fijación con tuerca y dispositivo de seguridad Adapter sleeves with lock nut and washer	Tuerca de bloqueo Lock nut	Dispositivo de seguridad Washer	Tuerca hidráulica Hydraulic Lock nut
17	20	32	24	7	M20x1	0.036	H 204	KM 4	MB 4	-
	20	32	28	7	M20x1	0.04	H 304	KM 4	MB 4	-
20	25	38	26	8	M 25x1.5	0.064	H 205	KM 5	MB 5	-
	25	38	35	8	M 25x1.5	0.085	H 2305	KM 5	MB 5	-
	25	38	29	9	M 25x1.5	0.071	H 305	KM 5	MB 5	-
25	30	45	27	8	M 30x1.5	0.086	H 206	KM 6	MB 6	-
	30	45	38	8	M 30x1.5	0.11	H 2306	KM 6	MB 6	-
	30	45	31	9	M 30x1.5	0.095	H 306	KM 6	MB 6	-
30	35	52	29	9	M 35x1.5	0.12	H 207	KM 7	MB 7	-
	35	52	43	9	M 35x1.5	0.16	H 2307	KM 7	MB 7	-
	35	52	35	10	M 35x1.5	0.14	H 307	KM 7	MB 7	-
35	40	58	31	10	M 40x1.5	0.16	H 208	KM 8	MB 8	-
	40	58	46	10	M 40x1.5	0.22	H 2308	KM 8	MB 8	-
	40	58	36	11	M 40x1.5	0.17	H 308	KM 8	MB 8	-
40	45	65	33	11	M 45x1.5	0.21	H 209	KM 9	MB 9	-
	45	65	50	11	M 45x1.5	0.27	H 2309	KM 9	MB 9	-
	45	65	39	12	M 45x1.5	0.23	H 309	KM 9	MB 9	-
45	50	70	35	12	M 50x1.5	0.24	H 210	KM 10	MB 10	HMV 10 E
	50	70	55	12	M 50x1.5	0.34	H 2310	KM 10	MB 10	HMV 10 E
	50	70	42	13	M 50x1.5	0.27	H 310	KM 10	MB 10	HMV 10 E
50	55	75	37	12.5	M 55x2	0.28	H 211	KM 11	MB 11	HMV 11 E
	55	75	59	12.5	M 55x2	0.39	H 2311	KM 11	MB 11	HMV 11 E
	55	75	45	13	M 55x2	0.34	H 311	KM 11	MB 11	HMV 11 E
55	60	80	38	12.5	M 60x2	0.31	H 212	KM 12	MB 12	HMV 12 E
	60	80	62	12.5	M 60x2	0.45	H 2312	KM 12	MB 12	HMV 12 E
	60	80	47	14	M 60x2	0.36	H 312	KM 12	MB 12	HMV 12 E
60	65	85	40	13.5	M 65x2	0.36	H 213	KM 13	MB 13	HMV 13 E
	65	85	65	13.5	M 65x2	0.52	H 2313	KM 13	MB 13	HMV 13 E
	65	85	50	13.5	M 65x2	0.42	H 313	KM 13	MB 13	HMV 13 E
	70	92	68	13.5	M 70x2	0.88	H 2314	KM 14	MB 14	HMV 14 E
	70	92	52	13.5	M 70x2	0.67	H 314	KM 14	MB 14	HMV 14 E
65	75	98	43	14.5	M 75x2	0.66	H 215	KM 15	MB 15	HMV 15 E
	75	98	73	14.5	M 75x2	1.1	H 2315	KM 15	MB 15	HMV 15 E
	75	98	55	14.5	M 75x2	0.78	H 315	KM 15	MB 15	HMV 15 E
70	80	105	46	17	M 80x2	0.81	H 216	KM 16	MB 16	HMV 16 E
	80	105	78	17	M 80x2	1.2	H 2316	KM 16	MB 16	HMV 16 E
	80	105	59	17	M 80x2	0.95	H 316	KM 16	MB 16	HMV 16 E

MANGUITOS DE FIJACIÓN
ADAPTER SLEEVES

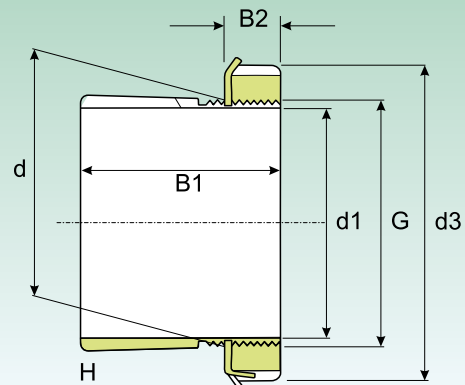

Dimensión Dimension						Peso (kg) Weight (Kg)	Sigla Designation			
d1 (mm)	d (mm)	d3 (mm)	B1 (mm)	B2 (mm)	G (mm)		Manguitos de fijación con tuerca y dispositivo de seguridad Adapter sleeves with lock nut and washer	Tuerca de bloqueo Lock nut	Dispositivo de seguridad Washer	Tuerca hidráulica Hydraulic Lock nut
75	85	110	50	18	M 85x2	0.94	H 217	KM 17	MB 17	HMV 17 E
	85	110	82	18	M 85x2	1.35	H 2317	KM 17	MB 17	HMV 17 E
	85	110	63	18	M 85x2	1.1	H 317	KM 17	MB 17	HMV 17 E
80	90	120	52	18	M 90x2	1.1	H 218	KM 18	MB 18	HMV 18 E
	90	120	86	18	M 90x2	1.6	H 2318	KM 18	MB 18	HMV 18 E
	90	120	65	18	M 90x2	1.3	H 318	KM 18	MB 18	HMV 18 E
85	95	125	55	19	M 95x2	1.25	H 219	KM 19	MB 19	HMV 19 E
	95	125	90	19	M 95x2	1.8	H 2319	KM 19	MB 19	HMV 19 E
	95	125	68	19	M 95x2	1.4	H 319	KM 19	MB 19	HMV 19 E
90	100	130	58	20	M 100x2	1.4	H 220	KM 20	MB 20	HMV 20 E
	100	130	97	20	M 100x2	2	H 2320	KM 20	MB 20	HMV 20 E
	100	130	76	20	M 100x2	1.8	H 3120	KM 20	MB 20	HMV 20 E
	100	130	71	20	M 100x2	1.6	H 320	KM 20	MB 20	HMV 20 E
100	110	145	63	21	M 110x2	1.8	H 222	KM 22	MB 22	HMV 22 E
	110	145	105	21	M 110x2	2.75	H 2322	KM 22	MB 22	HMV 22 E
	110	145	81	21	M 110x2	2.1	H 3122	KM 22	MB 22	HMV 22 E
	110	145	77	21	M 110x2	2.04	H 322	KM 22	MB 22	HMV 22 E
110	120	145	72	22	M 120x2	1.8	H 3024	KML 24	MBL 24	HMV 24 E
	120	155	112	22	M 120x2	3	H 2324	KM 24	MB 24	HMV 24 E
	120	155	88	22	M 120x2	2.5	H 3124	KM 24	MB 24	HMV 24 E
115	130	155	80	23	M 130x2	2.8	H 3026	KML 26	MBL 26	HMV 26 E
	130	165	121	23	M 130x2	4.45	H 2326	KM 26	MB 26	HMV 26 E
	130	165	92	23	M 130x2	3.45	H 3126	KM 26	MB 26	HMV 26 E
125	140	165	82	24	M 140x2	3.05	H 3028	KML 28	MBL 28	HMV 28 E
	140	180	131	24	M 140x2	5.4	H 2328	KM 28	MB 28	HMV 28 E
	140	180	97	24	M 140x2	4.1	H 3128	KM 28	MB 28	HMV 28 E
135	150	180	87	26	M 150x2	3.75	H 3030	KML 30	MBL 30	HMV 30 E
	150	195	139	26	M 150x2	6.4	H 2330	KM 30	MB 30	HMV 30 E
	150	195	111	26	M 150x2	5.25	H 3130	KM 30	MB 30	HMV 30 E
140	160	190	93	27.5	M 160x3	5.1	H 3032	KML 32	MBL 32	HMV 32 E
	160	210	147	27.5	M 160x3	8.8	H 2332	KM 32	MB 32	HMV 32 E
	160	210	119	27.5	M 160x3	7.25	H 3132	KM 32	MB 32	HMV 32 E
150	170	200	101	28.5	M 170x3	5.8	H 3034	KML 34	MBL 34	HMV 34 E
	170	220	154	28.5	M 170x3	9.9	H 2334	KM 34	MB 34	HMV 34 E
	170	220	122	28.5	M 170x3	8.1	H 3134	KM 34	MB 34	HMV 34 E
160	180	210	109	29.5	M 180x3	6.7	H 3036	KML 36	MBL 36	HMV 36 E
	180	210	87	29.5	M 180x3	5.7	H 3936	KML 36	MBL 36	HMV 36 E
	180	230	161	30	M 180x3	11	H 2336	KM 36	MB 36	HMV 36 E
	180	230	131	29.5	M 180x3	9.15	H 3136	KM 36	MB 36	HMV 36 E

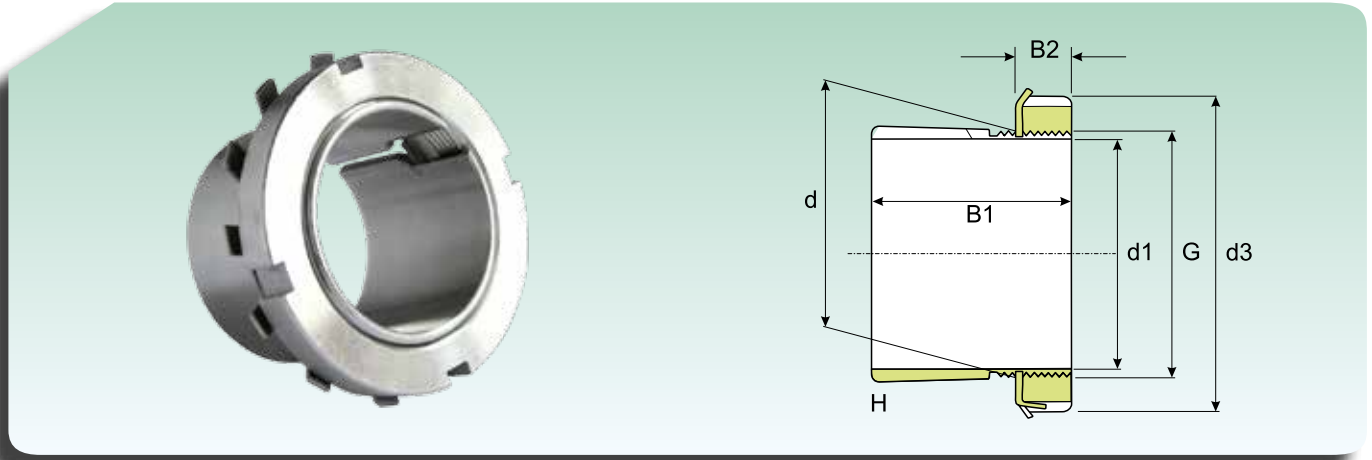
**MANGUITOS DE FIJACIÓN
ADAPTER SLEEVES**

Dimensión Dimension						Peso (kg) Weight (Kg)	Sigla Designation			
d1 (mm)	d (mm)	d3 (mm)	B1 (mm)	B2 (mm)	G (mm)		Manguitos de fijación con tuerca y dispositivo de seguridad Adapter sleeves with lock nut and washer	Tuerca de bloqueo Lock nut	Dispositivo de seguridad Washer	Tuerca hidráulica Hydraulic Lock nut
170	190	220	112	30.5	M 190x3	7.25	H 3038	KML 38	MBL 38	HMV 38 E
	190	220	89	30.5	M 190x3	6.2	H 3938	KML 38	MBL 38	HMV 38 E
	190	240	169	30.5	M 190x3	12	H 2338	KM 38	MB 38	HMV 38 E
	190	240	141	30.5	M 190x3	10.5	H 3138	KM 38	MB 38	HMV 38 E
180	200	240	120	31.5	M 200x3	8.9	H 3040	KML 40	MBL 40	HMV 40 E
	200	240	98	31.5	M 200x3	7.9	H 3940	KML 40	MBL 40	HMV 40 E
	200	250	176	31.5	M 200x3	13.5	H 2340	KM 40	MB 40	HMV 40 E
	200	250	150	31.5	M 200x3	12	H 3140	KM 40	MB 40	HMV 40 E
200	220	260	126	35	Tr 220x4	9.9	H 3044	KM 44	MB 44	HMV 44 E
	220	260	96	35	Tr 220x4	7.95	H 3944	KM 44	MB 44	HMV 44 E
	220	280	186	35	Tr 220x4	17	H 2344	KM 44	MB 44	HMV 44 E
	220	280	161	35	Tr 220x4	15	H 3144	KM 44	MB 44	HMV 44 E
220	240	290	133	34	Tr 240x4	12	H 3048	KM 48	MB 48	HMV 48 E
	240	290	101	34	Tr 240x4	11	H 3948	KM 48	MB 48	HMV 48 E
	240	300	199	34	Tr 240x4	19	H 2348	KM 48	MB 48	HMV 48 E
	240	300	172	34	Tr 240x4	16.5	H 3148	KM 48	MB 48	HMV 48 E

**MANGUITOS DE FIJACIÓN
ADAPTER SLEEVES**

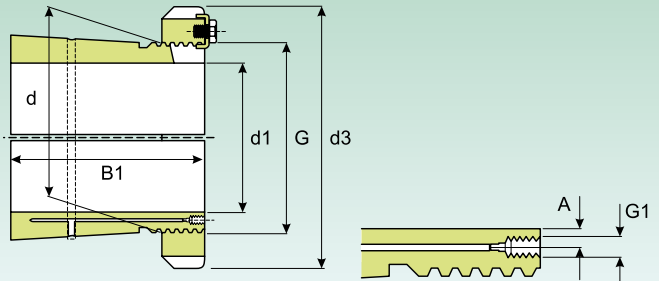

Dimensión Dimension							Peso (kg) Weight (Kg)	Sigla Designation			
d1 (mm)	d (mm)	d3 (mm)	B1 (mm)	A (mm)	G1 (mm)	G (mm)		Manguitos de fijación con tuerca y dispositivo de seguridad Adapter sleeves with lock nut and washer	Tuerca de bloqueo Lock nut	Dispositivo de seguridad Washer	Tuerca hidraulica Hydraulic Lock nut
200	220	260	96	4.2	M6	Tr 220x4	7.95	OH 3944 H	HM 3044	MS 3044	HMV 44 E
	220	260	126	4.2	M6	Tr 220x4	9.9	OH 3044 H	HM 3044	MS 3044	HMV 44 E
	220	280	161	4.2	M6	Tr 220x4	15	OH 3144 H	HM 3044	MB 44	HMV 44 E
	220	280	186	4.2	M6	Tr 220x4	17	OH 2344 H	HM 3044	MB 44	HMV 44 E
220	240	290	101	4.2	M6	Tr 240x4	11	OH 3948 H	HM 3048	MS 3052-48	HMV 48 E
	240	290	133	4.2	M6	Tr 240x4	12	OH 3048 H	HM 3048	MS 3052-48	HMV 48 E
	240	300	172	4.2	M6	Tr 240x4	16,5	OH 3148 H	HM 3048	MB 48	HMV 48 E
	240	300	199	4.2	M6	Tr 240x4	19	OH 2348 H	HM 3048	MB 48	HMV 48 E
240	260	310	145	4.2	M6	Tr 260x4	13.5	OH 3052 H	HM 3052	MS 3052-48	HMV 52 E
	260	310	116	4.2	M6	Tr 260x4	11.7	OH 3952 H	HM 3052	MS 3052-48	HMV 52 E
	260	330	190	4.2	M6	Tr 260x4	21	OH 3152 H	HM 3052	MB 52	HMV 52 E
260	280	330	152	4.2	M6	Tr 280x4	16	OH 3056 H	HM 3056	MS 3056	HMV 56 E
	280	330	121	4.2	M6	Tr 280x4	15.3	OH 3956 H	HM 3056	MS 3056	HMV 56 E
	280	350	195	4.2	M6	Tr 280x4	23	OH 3156 H	HM 3056	MB 56	HMV 56 E
280	300	360	168	4.2	M6	Tr 300x4	20.5	OH 3060 H	HM 3060	MS 3060	HMV 60 E
	300	360	140	4.2	M6	Tr 300x4	20	OH 3960 H	HM 3060	MS 3060	HMV 60 E
	300	380	208	4.2	M6	Tr 300x4	29	OH 3160 H	HM 3160	MS 3160	HMV 60 E
	300	380	240	4.2	M6	Tr 300x4	32	OH 3260 H	HM 3160	MS 3160	HMV 60 E
300	320	380	171	4	M6	Tr 320x5	22	OH 3064 H	HM 3064	MS 3068-64	HMV 64 E
	320	380	140	4	M6	Tr 320x5	21.5	OH 3964 H	HM 3064	MS 3068-64	HMV 64 E
	320	400	226	4	M6	Tr 320x5	32	OH 3164 H	HM 3164	MS 3164	HMV 64 E
	320	400	258	4	M6	Tr 320x5	35	OH 3264 H	HM 3164	MS 3164	HMV 64 E
320	340	400	187	4	M6	Tr 340x5	27	OH 3068 H	HM 3068	MS 3068-64	HMV 68 E
	340	400	144	4	M6	Tr 340x5	24.5	OH 3968 H	HM 3068	MS 3068-64	HMV 68 E
	340	440	254	4	M6	Tr 340x5	50	OH 3168 H	HM 3168	MS 3172-68	HMV 68 E
	340	440	288	4	M6	Tr 340x5	51.5	OH 3268 H	HM 3168	MS 3172-68	HMV 68 E
340	360	420	188	4	M6	Tr 360x5	29	OH 3072 H	HM 3072	MS 3072	HMV 72 E
	360	420	144	4	M6	Tr 360x5	25.2	OH 3972 H	HM 3072	MS 3072	HMV 72 E
	360	460	259	4	M6	Tr 360x5	56	OH 3172 H	HM 3172	MS 3172-68	HMV 72 E
	360	460	299	4	M6	Tr 360x5	60.5	OH 3272 H	HM 3172	MS 3172-68	HMV 72 E
360	380	450	193	4	M6	Tr 380x5	35.5	OH 3076 H	HM 3076	MS 3080-76	HMV 76 E
	380	490	264	4	M6	Tr 380x5	61.5	OH 3176 H	HM 3176	MS 3176	HMV 76 E
	380	490	310	4	M6	Tr 380x5	69.5	OH 3276 H	HM 3176	MS 3176	HMV 76 E
380	400	470	210	4	M6	Tr 400x5	40	OH 3080 H	HM 3080	MS 3080-76	HMV 80 E
	400	470	168	4	M6	Tr 400x5	35	OH 3980 H	HM 3080	MS 3080-76	HMV 80 E
	400	520	272	4	M6	Tr 400x5	73	OH 3180 H	HM 3180	MS 3184-80	HMV 80 E
	400	520	328	4	M6	Tr 400x5	87	OH 3280 H	HM 3180	MS 3184-80	HMV 80 E
400	420	490	212	4	M6	Tr 420x5	47	OH 3084 H	HM 3084	MS 3084	HMV 84 E
	420	490	168	4	M6	Tr 420x5	36	OH 3984 H	HM 3084	MS 3084	HMV 84 E
	420	540	304	4	M6	Tr 420x5	80	OH 3184 H	HM 3184	MS 3184-80	HMV 84 E
	420	540	352	4	M6	Tr 420x5	96	OH 3284 H	HM 3184	MS 3184-80	HMV 84 E

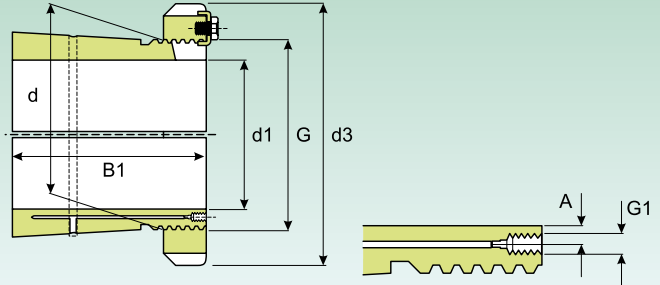
**MANGUITOS DE FIJACIÓN
ADAPTER SLEEVES**

Dimensión Dimension							Peso (kg) Weight (Kg)	Sigla Designation			
d1 (mm)	d (mm)	d3 (mm)	B1 (mm)	A (mm)	G1 (mm)	G (mm)		Manguitos de fijación con tuerca y dispositivo de seguridad Adapter sleeves with lock nut and washer	Tuerca de bloqueo Lock nut	Dispositivo de seguridad Washer	Tuerca hidraulica Hydraulic Lock nut
410	440	520	228	6.5	M8	Tr 440x5	65	OH 3088 H	HM 3088	MS 3092-88	HMV 88 E
	440	520	189	6.5	M8	Tr 440x5	58	OH 3988 H	HM 3088	MS 3092-88	HMV 88 E
	440	560	307	6.5	M8	Tr 440x5	95	OH 3188 H	HM 3188	MS 3192-88	HMV 88 E
	440	560	361	6.5	M8	Tr 440x5	117	OH 3288 H	HM 3188	MS 3192-88	HMV 88 E
430	460	540	234	6.5	M8	Tr 460x5	71	OH 3092 H	HM 3092	MS 3092-88	HMV 92 E
	460	540	189	6.5	M8	Tr 460x5	60	OH 3992 H	HM 3092	MS 3092-88	HMV 92 E
	460	580	326	6.5	M8	Tr 460x5	119	OH 3192 H	HM 3192	MS 3192-88	HMV 92 E
	460	580	382	6.5	M8	Tr 460x5	134	OH 3292 H	HM 3192	MS 3192-88	HMV 92 E
450	480	560	237	6.5	M8	Tr 480x5	75	OH 3096 H	HM 3096	MS 30/500-96	HMV 96 E
	480	560	200	6.5	M8	Tr 480x5	66	OH 3996 H	HM 3096	MS 30/500-96	HMV 96 E
	480	620	335	6.5	M8	Tr 480x5	135	OH 3196 H	HM 3196	MS 3196	HMV 96 E
	480	620	397	6.5	M8	Tr 480x5	153	OH 3296 H	HM 3196	MS 3196	HMV 96 E
470	500	580	247	6.5	M8	Tr 500x5	82	OH 30/500 H	HM 30/500	MS 30/500-96	HMV 100 E
	500	580	208	6.5	M8	Tr 500x5	74.3	OH 39/500 H	HM 30/500	MS 30/500-96	HMV 100 E
	500	630	356	6.5	M8	Tr 500x5	145	OH 31/500 H	HM 31/500	MS 31/500	HMV 100 E
	500	630	428	6	M8	Tr 500x5	170	OH 32/500 H	HM 31/500	MS 31/500	HMV 100 E
500	530	630	265	6	M8	Tr 530x6	105	OH 30/530 H	HM 30/530	MS 30/600-530	HMV 106 E
	530	630	216	6	M8	Tr 530x6	87.9	OH 39/530 H	HM 30/530	MS 30/600-530	HMV 106 E
	530	670	364	6	M8	Tr 530x6	161	OH 31/530 H	HM 31/530	MS 31/530	HMV 106 E
	530	670	447	6	M8	Tr 530x6	192	OH 32/530 H	HM 31/530	MS 31/530	HMV 106 E
530	560	650	282	6	M8	Tr 560x6	112	OH 30/560 H	HM 30/560	MS 30/560	HMV 112 E
	560	650	227	6	M8	Tr 560x6	95	OH 39/560 H	HM 30/560	MS 30/560	HMV 112 E
	560	710	377	6	M8	Tr 560x6	185	OH 31/560 H	HM 31/560	MS 31/600-560	HMV 112 E
	560	710	462	6	M8	Tr 560x6	219	OH 32/560 H	HM 31/560	MS 31/600-560	HMV 112 E
560	600	700	289	8	G 1/8	Tr 300x4	147	OH 30/600 H	HM 30/600	MS 30/600-530	HMV 120 E
	600	700	239	8	G 1/8	Tr 300x4	127	OH 39/600 H	HM 30/600	MS 30/600-530	HMV 120 E
	600	750	399	8	G 1/8	Tr 300x4	234	OH 31/600 H	HM 31/600	MS 31/600-560	HMV 120 E
	600	750	487	8	G 1/8	Tr 300x4	278	OH 32/600 H	HM 31/600	MS 31/600-560	HMV 120 E
600	630	730	301	6	M8	Tr 630x6	138	OH 30/630 H	HM 30/630	MS 30/630	HMV 126 E
	630	730	254	6	M8	Tr 630x6	124	OH 39/630 H	HM 30/630	MS 30/630	HMV 126 E
	630	800	424	6	M8	Tr 630x6	254	OH 31/630 H	HM 31/630	MS 31/630	HMV 126 E
630	670	780	324	8	G 1/8	Tr 670x6	190	OH 30/670 H	HM 30/670	MS 30/670	HMV 134 E
	670	780	264	8	G 1/8	Tr 670x6	162	OH 39/670 H	HM 30/670	MS 30/670	HMV 134 E
	670	850	456	8	G 1/8	Tr 670x6	340	OH 31/670 H	HM 31/670	MS 31/670	HMV 134 E
	670	850	558	8	G 1/8	Tr 670x6	401	OH 32/670 H	HM 31/670	MS 31/670	HMV 134 E
670	710	830	342	8	G 1/8	Tr 710x7	228	OH 30/710 H	HM 30/710	MS 30/710	HMV 142 E
	710	830	286	8	G 1/8	Tr 710x7	183	OH 39/710 H	HM 30/710	MS 30/710	HMV 142 E
	710	900	467	8	G 1/8	Tr 710x7	392	OH 31/710 H	HM 31/710	MS 31/710	HMV 142 E
	710	900	572	8	G 1/8	Tr 710x7	459	OH 32/710 H	HM 31/710	MS 31/710	HMV 142 E
710	750	870	356	8	G 1/8	Tr 750x7	246	OH 30/750 H	HM 30/750	MS 30/800-750	HMV 150 E
	750	870	291	8	G 1/8	Tr 750x7	211	OH 39/750 H	HM 30/750	MS 30/800-750	HMV 150 E
	750	950	493	8	G 1/8	Tr 750x7	451	OH 31/750 H	HM 31/750	MS 31/800-750	HMV 150 E
	750	950	603	8	G 1/8	Tr 750x7	526	OH 32/750 H	HM 31/750	MS 31/800-750	HMV 150 E

MANGUITOS DE FIJACIÓN
ADAPTER SLEEVES

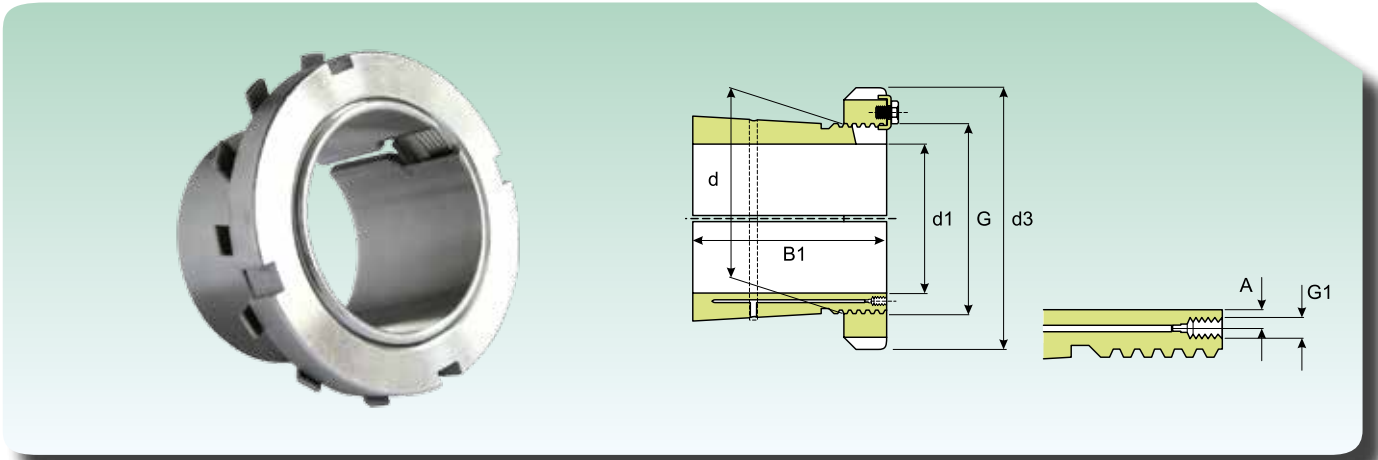

Dimensión Dimension							Peso (kg) Weight (kg)	Sigla Designation			
d1 (mm)	d (mm)	d3 (mm)	B1 (mm)	A (mm)	G1 (mm)	G (mm)		Manguitos de fijación con tuerca y dispositivo de seguridad Adapter sleeves with lock nut and washer	Tuerca de bloqueo Lock nut	Dispositivo de seguridad Washer	Tuerca hidraulica Hydraulic Lock nut
750	800	920	366	10	G 1/8	Tr 800x7	302	OH 30/800 H	HM 30/800	MS 30/800-750	HMV 160 E
	800	920	303	10	G 1/8	Tr 800x7	259	OH 39/800 H	HM 30/800	MS 30/800-750	HMV 160 E
	800	1000	505	10	G 1/8	Tr 800x7	535	OH 31/800 H	HM 31/800	MS 31/800-750	HMV 160 E
	800	1000	618	10	G 1/8	Tr 800x7	629	OH 32/800 H	HM 31/800	MS 31/800-750	HMV 160 E
800	850	980	380	10	G 1/8	Tr 850x7	341	OH 30/850 H	HM 30/850	MS 30/900-850	HMV 170 E
	850	980	308	10	G 1/8	Tr 850x7	288	OH 39/850 H	HM 30/850	MS 30/900-850	HMV 170 E
	850	1060	536	10	G 1/8	Tr 850x7	616	OH 31/850 H	HM 31/850	MS 31/850	HMV 170 E
	850	1060	651	10	G 1/8	Tr 850x7	722	OH 32/850 H	HM 31/850	MS 31/850	HMV 170 E
850	900	1030	400	10	G 1/8	Tr 900x7	387	OH 30/900 H	HM 30/900	MS 30/900-850	HMV 180 E
	900	1030	326	10	G 1/8	Tr 900x7	330	OH 39/900 H	HM 30/900	MS 30/900-850	HMV 180 E
	900	1120	557	10	G 1/8	Tr 900x7	677	OH 31/900 H	HM 31/900	MS 31/900	HMV 180 E
	900	1120	660	10	G 1/8	Tr 900x7	776	OH 32/900 H	HM 31/900	MS 31/900	HMV 180 E
900	950	1080	420	10	G 1/8	Tr 950x8	424	OH 30/950 H	HM 30/950	MS 30/950	HMV 190 E
	950	1080	344	10	G 1/8	Tr 950x8	362	OH 39/950 H	HM 30/950	MS 30/950	HMV 190 E
	950	1170	583	10	G 1/8	Tr 950x8	738	OH 31/950 H	HM 31/950	MS 31/950	HMV 190 E
	950	1170	675	10	G 1/8	Tr 950x8	834	OH 32/950 H	HM 31/950	MS 31/950	HMV 190 E
950	1000	1140	430	12	G 1/8	Tr 1000x8	470	OH 30/1000 H	HM 30/1000	MS 30/1000	HMV 200 E
	1000	1140	358	12	G 1/8	Tr 1000x8	407	OH 39/1000 H	HM 30/1000	MS 30/1000	HMV 200 E
	1000	1240	609	12	G 1/8	Tr 1000x8	842	OH 31/1000 H	HM 31/1000	MS 31/1000	HMV 200 E
	1000	1240	707	12	G 1/8	Tr 1000x8	952	OH 32/1000 H	HM 31/1000	MS 31/1000	HMV 200 E
1000	1060	1200	447	12	G 1/8	Tr 1060x8	571	OH 30/1060 H	HM 30/1060	MS 30/1000	HMV 212 E
	1060	1200	372	12	G 1/8	Tr 1060x8	490	OH 39/1060 H	HM 30/1060	MS 30/1000	HMV 212 E
	1060	1300	622	12	G 1/8	Tr 1060x8	984	OH 31/1060 H	HM 31/1060	MS 31/1000	HMV 212 E

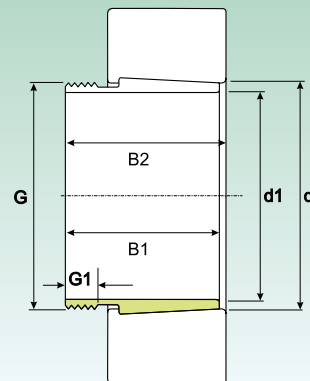
**MANGUITOS DE DESMONTAJE
WITHDRAWAL SLEEVES**

Dimensión Dimension								Peso (kg) Weight (Kg)	Sigla Designation		
d1 (mm)	d (mm)	B1 ¹⁾ (mm)	B2 (mm)	G (mm)	G1 (mm)	G2 (mm)	A (mm)		Manguitos dedesmontaje Withdrawal sleeves	Tuerca para el desmontaje Dismounting nut	Tuerca hidráulica Hydraulic lock nut
35	40	29	32	M 45 x 1.5	6	-	-	0.09	AH 308	KM 9	-
	40	40	43	M 45 x 1.5	7	-	-	0.13	AH 2308	KM 9	-
40	45	31	34	M 50 x 1.5	6	-	-	0.12	AH 309	KM 10	HMV 10 E
	45	44	47	M 50 x 1.5	7	-	-	0.16	AH 2309	KM 10	HMV 10 E
45	50	35	38	M 55 x 2	7	-	-	0.13	AHX 310	KM 11	HMV 11 E
	50	50	53	M 55 x 2	9	-	-	0.19	AHX 2310	KM 11	HMV 11 E
50	55	37	40	M 60 x 2	7	-	-	0.16	AHX 311	KM 12	HMV 12 E
	55	54	57	M 60 x 2	10	-	-	0.26	AHX 2311	KM 12	HMV 12 E
55	60	40	43	M 65 x 2	8	-	-	0.19	AHX 312	KM 13	HMV 13 E
	60	58	61	M 65 x 2	11	-	-	0.3	AHX 2312	KM 13	HMV 13 E
60	65	42	45	M 75 x 2	8	-	-	0.35	AH 313	KM 15	HMV 15 E
	65	61	64	M 75 x 2	12	-	-	0.39	AH 2313	KM 15	HMV 15 E
65	70	43	47	M 80 x 2	8	-	-	0.24	AH 314	KM 16	HMV 16 E
	70	64	68	M 80 x 2	12	-	-	0.42	AHX 2314	KM 16	HMV 16 E
70	75	45	49	M 85 x 2	8	-	-	0.29	AH 315	KM 17	HMV 17 E
	75	68	72	M 85 x 2	12	-	-	0.48	AHX 2315	KM 17	HMV 17 E
75	80	48	52	M 90 x 2	8	-	-	0.37	AH 316	KM 18	HMV 18 E
	80	71	75	M 90 x 2	12	-	-	0.57	AHX 2316	KM 18	HMV 18 E
80	85	52	56	M 95 x 2	9	-	-	0.43	AHX 317	KM 19	HMV 19 E
	85	74	78	M 95 x 2	13	-	-	0.65	AHX 2317	KM 19	HMV 19 E
85	90	53	57	M 100 x 2	9	-	-	0.46	AHX 318	KM 20	HMV 20 E
	90	63	67	M 100 x 2	10	-	-	0.57	AHX 3218	KM 20	HMV 20 E
	90	79	83	M 100 x 2	14	-	-	0.76	AHX 2318	KM 20	HMV 20 E
90	95	57	61	M 105 x 2	10	-	-	0.54	AHX 319	KM 21	HMV 21 E
	95	85	89	M 105 x 2	16	-	-	0.9	AHX 2319	KM 21	HMV 21 E
95	100	59	63	M 110 x 2	10	-	-	0.58	AHX 320	KM 22	HMV 22 E
	100	64	68	M 110 x 2	11	-	-	0.66	AHX 3120	KM 22	HMV 22 E
	100	73	77	M 110 x 2	11	-	-	0.76	AHX 3220	KM 22	HMV 22 E
	100	90	94	M 110 x 2	16	-	-	1	AHX 2320	KM 22	HMV 22 E
105	110	63	67	M 120 x 2	12	-	-	0.77	AHX 322	KM 24	HMV 24 E
	110	68	72	M 120 x 2	11	-	-	0.76	AHX 3122	KM 24	HMV 24 E
	110	82	91	M 125 x 2	11	-	-	0.71	AH 24122	KM 23	HMV 23 E
	110	82	86	M 125 x 2	16	-	-	1	AHX 3222	KM 25	HMV 25 E
	110	98	102	M 125 x 2	13	-	-	1.3	AHX 2322	KM 25	HMV 25 E
115	120	60	64	M 130 x 2	13	-	-	0.73	AHX 3024	KM 26	HMV 26 E
	120	73	82	M 125 x 2	12	-	-	0.7	AH 24024	KM 25	HMV 25 E
	120	75	79	M 130 x 2	13	-	-	0.94	AHX 3124	KM 26	HMV 26 E
	120	90	94	M 135 x 2	17	-	-	1.7	AHX 3224	KM 27	HMV 27 E
	120	93	102	M 130 x 2	13	-	-	1	AH 24124	KM 26	HMV 26 E
	120	105	109	M 135 x 2	13	-	-	1.55	AHX 2324	KM 27	HMV 27 E

1) Anchura manguito antes del prensado en el agujero interior del rodamiento.
1) Width of taper adapter, before being pressed inside inner bore of bearing.

MANGUITOS DE DESMONTAJE
WITHDRAWAL SLEEVES

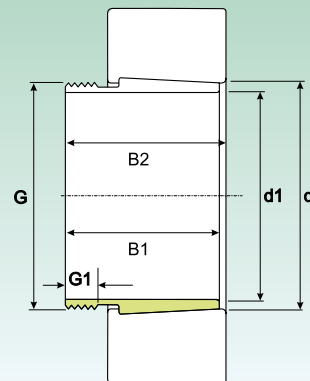

Dimensión Dimension								Peso (kg) Weight (Kg)	Sigla Designation		
d1 (mm)	d (mm)	B1 ¹⁾ (mm)	B2 (mm)	G (mm)	G1 (mm)	G2 (mm)	A (mm)		Manguitos dedesmontaje Withdrawal sleeves	Tuerca para el desmontaje Dismounting nut	Tuerca hidráulica Hydraulic lock nut
125	130	67	71	M 140 x 2	14	-	-	0.91	AHX 3026	KM 28	HMV 28 E
	130	78	82	M 140 x 2	12	-	-	1.1	AHX 3126	KM 28	HMV 28 E
	130	83	93	M 135 x 2	15	-	-	0.88	AH 24026	KM 27	HMV 27 E
	130	94	104	M 140 x 2	19	-	-	1.15	AH 24126	KM 28	HMV 28 E
	130	98	102	M 145 x 2	14	-	-	1.5	AHX 3226	KM 29	HMV 29 E
	130	115	119	M 145 x 2	14	-	-	1.85	AHX 2326	KM 29	HMV 29 E
135	140	68	73	M 150 x 2	14	-	-	1	AHX 3028	KM 30	HMV 30 E
	140	83	93	M 145 x 2	14	-	-	0.95	AH 24028	KM 29	HMV 29 E
	140	83	88	M 150 x 2	15	-	-	1.3	AHX 3128	KM 30	HMV 30 E
	140	99	109	M 150 x 2	20	-	-	1.3	AH 24128	KM 30	HMV 30 E
	140	104	109	M 155 x 3	14	-	-	1.75	AHX 3228	KM 31	HMV 31 E
	140	125	130	M 155 x 3	14	-	-	2.55	AHX 2328	KM 31	HMV 31 E
145	150	72	77	M 160 x 3	15	-	-	1.15	AHX 3030	KM 32	HMV 32 E
	150	90	101	M 155 x 3	15	-	-	1.5	AH 24030	KM 31	HMV 31 E
	150	96	101	M 165 x 3	17	-	-	1.7	AHX 3130	KM 33	HMV 33 E
	150	114	119	M 165 x 3	24	-	-	2.1	AHX 3230	KM 33	HMV 33 E
	150	115	126	M 160 x 3	15	-	-	1.55	AH 24130	KM 32	HMV 32 E
	150	135	140	M 165 x 3	15	-	-	2.75	AHX 2330	KM 33	HMV 33 E
150	160	77	82	M 170 x 3	16	-	-	2	AH 3032	KM 34	HMV 34 E
	160	95	106	M 170 x 3	16	-	-	2.3	AH 24032	KM 34	HMV 34 E
	160	103	108	M 180 x 3	20	-	-	3	AH 3132	KM 36	HMV 36 E
	160	124	135	M 170 x 3	24	-	-	3	AH 24132	KM 36	HMV 34 E
	160	124	130	M 180 x 3	15	-	-	3.7	AH 3232	KM 34	HMV 36 E
	160	140	146	M 180 x 3	15	-	-	4.35	AH 2332	KM 36	HMV 36 E
160	170	85	90	M 180 x 3	17	-	-	2.45	AH 3034	KM 36	HMV 36 E
	170	104	109	M 190 x 3	16	-	-	3.2	AH 3134	KM 38	HMV 38 E
	170	106	117	M 180 x 3	24	-	-	2.7	AH 24034	KM 36	HMV 36 E
	170	125	136	M 180 x 3	24	-	-	3.25	AH 24134	KM 36	HMV 36 E
	170	134	140	M 190 x 3	16	-	-	4.35	AH 3234	KM 38	HMV 38 E
	170	146	152	M 190 x 3	16	-	-	4.85	AH 2334	KM 38	HMV 38 E
170	180	92	98	M 190 x 3	17	-	-	2.8	AH 3036	KM 38	HMV 38 E
	180	105	110	M 200 x 3	17	-	-	3.4	AH 2236	KM 40	HMV 40 E
	180	116	127	M 190 x 3	19	-	-	3.3	AH 24036	KM 38	HMV 38 E
	180	116	122	M 200 x 3	24	-	-	3.9	AH 3136	KM 40	HMV 40 E
	180	134	145	M 190 x 3	26	-	-	3.75	AH 24136	KM 38	HMV 38 E
	180	140	146	M 200 x 3	16	-	-	4.85	AH 3236	KM 40	HMV 40 E
180	154	160	M 200 x 3	16	-	-	5.5	AH 2336	KM 40	HMV 40 E	
180	190	96	102	M 205 x 4	18	-	-	3.3	AH 3038	HM 42	HMV 41 E
	190	112	117	M 210 x 4	18	-	-	3.9	AH 2238	HM 42	HMV 42 E
	190	118	131	M 200 x 3	20	-	-	3.55	AH 24038	HM 40	HMV 41 E
	190	125	131	M 210 x 4	25	-	-	4.5	AH 3138	HM 42	HMV 42 E
	190	145	152	M 210 x 4	26	-	-	5.9	AH 3238	HM 42	HMV 42 E
	190	146	159	M 200 x 3	18	-	-	4.45	AH 24138	HM 40	HMV 40 E
	190	160	167	M 210 x 4	18	-	-	6.1	AH 2338	HM 42	HMV 42 E

1) Anchura manguito antes del prensado en el agujero interior del rodamiento.
1) Width of taper adapter, before being pressed inside inner bore of bearing.

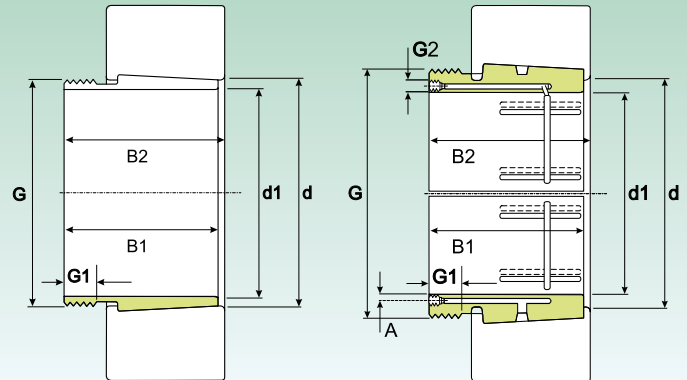
**MANGUITOS DE DESMONTAJE
WITHDRAWAL SLEEVES**

Dimensión Dimension								Peso (kg) Weight (Kg)	Sigla Designation		
d1 (mm)	d (mm)	B1 ¹⁾ (mm)	B2 (mm)	G (mm)	G1 (mm)	G2 (mm)	A (mm)		Manguitos dedesmontaje Withdrawal sleeves	Tuerca para el desmontaje Dismounting nut	Tuerca hidráulica Hydraulic lock nut
190	200	102	108	Tr 215 x 4	19	-	-	3.7	AH 3040	HM 43	HMV 43 E
	200	118	123	Tr 220 x 4	21	-	-	4.7	AH 2240	HM 44	HMV 44 E
	200	127	140	Tr 210 x 4	25	-	-	4	AH 24040	HM 42	HMV 42 E
	200	134	140	Tr 210 x 4	30	-	-	5.65	AH 3140	HM 44	HMV 44 E
	200	153	160	Tr 210 x 4	18	-	-	6.6	AH 3240	HM 44	HMV 44 E
	200	158	171	Tr 210 x 4	18	-	-	5.05	AH 24140	HM 42	HMV 42 E
	200	170	177	Tr 220 x 4	30	-	-	7.6	AH 2340	HM 44	HMV 44 E
200	220	111	117	Tr 235 x 4	20	-	-	7.47	AH 3044	HM 47	HMV 47 E
	220	111	117	Tr 235 x 4	20	G 1/8	7.5	7.3	AOH 3044	HM 47	HMV 47 E
	220	130	136	Tr 240 x 4	23	G 1/4	9	9.4	AOH 2244	HM 48	HMV 48 E
	220	138	152	Tr 230 x 4	30	G 1/8	6.5	8.2	AOH 24044	HM 46	HMV 46 E
	220	145	151	Tr 240 x 4	20	G 1/4	9	9.3	AOH 3144	HM 48	HMV 48 E
	220	170	184	Tr 230 x 4	20	G 1/8	6.5	10	AOH 24144	HM 46	HMV 46 E
	220	181	189	Tr 240 x 4	30	G 1/4	9	13.5	AOH 2344	HM 48	HMV 48 E
220	240	116	123	Tr 260 x 4	21	G 1/4	9	7.95	AOH 3048	HM 52	HMV 52 E
	240	138	153	Tr 250 x 4	20	G 1/8	6.5	8.05	AOH 24048	HM 50	HMV 50 E
	240	144	150	Tr 260 x 4	30	G 1/4	9	11.5	AOH 2248	HM 52	HMV 52 E
	240	154	161	Tr 260 x 4	25	G 1/4	9	12	AOH 3148	HM 52	HMV 52 E
	240	180	195	Tr 260 x 4	20	G 1/4	9	11.5	AOH 24148	HM 52	HMV 52 E
	240	189	197	Tr 260 x 4	30	G 1/4	9	14	AOH 2348	HM 52	HMV 52 E
240	260	128	135	Tr 280 x 4	23	G 1/4	9	9.6	AOH 3052	HM 56	HMV 56 E
	260	155	161	Tr 290 x 4	23	G 1/4	9.5	12.5	AOH 2252	HM 58	HMV 58 E
	260	162	178	Tr 270 x 4	22	G 1/8	6.5	10.5	AOH 24052	HM 54	HMV 54 E
	260	172	179	Tr 290 x 4	26	G 1/4	9.5	16	AOH 3152	HM 56	HMV 56 E
	260	202	218	Tr 280 x 4	22	G 1/4	9	14	AOH 24152	HM 56	HMV 56 E
	260	205	213	Tr 290 x 4	30	G 1/4	10.5	17.5	AOH 2352	HM 58	HMV 58 E
260	280	131	139	Tr 300 x 4	24	G 1/4	9	11	AOH 3056	HM 60	HMV 60 E
	280	155	163	Tr 310 x 5	21	G 1/4	9.5	15	AOH 2256	HM 62	HMV 62 E
	280	162	179	Tr 290 x 4	22	G 1/8	6.5	11.5	AOH 24056	HM 58	HMV 58 E
	280	175	183	Tr 310 x 5	28	G 1/4	9.5	15.5	AOH 3156	HM 62	HMV 62 E
	280	202	219	Tr 300 x 4	22	G 1/8	9	15	AOH 24156	HM 60	HMV 60 E
	280	212	220	Tr 310 x 5	30	G 1/4	11	19.5	AOH 2356	HM 62	HMV 62 E
280	300	145	153	Tr 320 x 5	26	G 1/4	9	13	AOH 3060	HM 3064	HMV 64 E
	300	170	178	Tr 330 x 5	26	G 1/4	10	18	AOH 2260	HM 66	HMV 62 E
	300	184	202	Tr 310 x 5	24	G 1/8	6.5	14	AOH 24060	HM 62	HMV 58 E
	300	192	200	Tr 330 x 5	30	G 1/4	10.5	19	AOH 3160	HM 66	HMV 62 E
	300	224	242	Tr 320 x 5	24	G 1/4	9	18.5	AOH 24160	HM 3164	HMV 64 E
	300	228	236	Tr 330 x 5	34	G 1/4	9	23.5	AOH 3260	HM 66	HMV 66 E
300	320	149	157	Tr 345 x 5	27	G 1/4	9.5	17.5	AOH 3064	HM 69	HMV 69 E
	320	180	190	Tr 350 x 5	27	G 1/4	10	20	AOH 2264	HM 70	HMV 70 E
	320	184	202	Tr 330 x 5	24	G 1/8	6.5	15	AOH 24064	HM 66	HMV 66 E
	320	209	217	Tr 350 x 5	31	G 1/4	10.5	22.5	AOH 3164	HM 70	HMV 70 E
	320	242	260	Tr 340 x 5	24	G 1/4	9.5	20.5	AOH 24164	HM 3168	HMV 68 E
	320	246	254	Tr 350 x 5	24	G 1/4	12	27.5	AOH 3264	HM 70	HMV 70 E

1) Anchura manguito antes del prensado en el agujero interior del rodamiento.
1) Width of taper adapter, before being pressed inside inner bore of bearing.

MANGUITOS DE DESMONTAJE
WITHDRAWAL SLEEVES

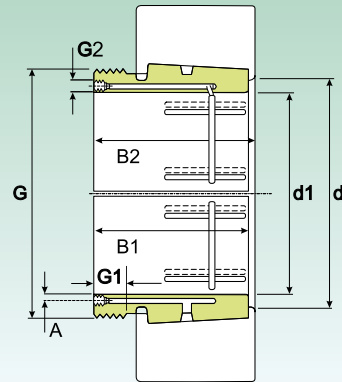

Dimensión Dimension								Peso (kg) Weight (Kg)	Sigla Designation		
d1 (mm)	d (mm)	B1 ¹⁾ (mm)	B2 (mm)	G (mm)	G1 (mm)	G2 (mm)	A (mm)		Manguitos dedesmontaje Withdrawal sleeves	Tuerca para el desmontaje Dismounting nut	Tuerca hidráulica Hydraulic lock nut
320	340	162	171	Tr 365 x 5	28	G 1/4	9.5	17.5	AOH 3068	HM 73	HMV 73 E
	340	206	225	Tr 350 x 5	26	G 1/4	9	18	AOH 24068	HM 3072	HMV 72 E
	340	225	234	Tr 370 x 5	26.5	G 1/4	9	28.5	AOH 3168	HM 74	HMV 74 E
	340	264	273	Tr 370 x 5	38	G 1/4	9	32	AOH 3268	HM 74	HMV 74 E
	340	269	288	Tr 360 x 5	26	G 1/4	9	25.5	AOH 24168	HM 3172	HMV 72 E
340	360	167	176	Tr 385 x 5	30	G 1/4	9.5	19	AOH 3072	HM 77	HMV 77 E
	360	206	226	Tr 380 x 5	26	G 1/4	9	20	AOH 24072	HM 3076	HMV 80 E
	360	229	238	Tr 400 x 5	35	G 1/4	11	30	AOH 3172	HM 3180	HMV 76 E
	360	269	289	Tr 380 x 5	26	G 1/4	9	26	AOH 24172	HM 3176	HMV 76 E
	360	274	283	Tr 400 x 5	40	G 1/4	13	33	AOH 3272	HM 3180	HMV 80 E
360	380	170	180	Tr 410 x 5	31	G 1/4	9.5	23.5	AOH 3076	HM 82	HMV 82 E
	380	208	228	Tr 400 x 5	28	G 1/4	9	23.5	AOH 24076	HM 3080	HMV 80 E
	380	232	242	Tr 420 x 5	36	G 1/4	11	38	AOH 3176	HM 3180	HMV 80 E
	380	271	291	Tr 400 x 5	28	G 1/4	9	31	AOH 24176	HM 3180	HMV 80 E
	380	284	294	Tr 420 x 5	42	G 1/4	13	45.5	AOH 3276	HM 3184	HMV 84 E
380	400	183	193	Tr 430 x 5	33	G 1/4	10	27	AOH 3080	HM 86	HMV 86 E
	400	228	248	Tr 420 x 5	28	G 1/4	9	27	AOH 24080	HM 3084	HMV 84 E
	400	240	250	Tr 440 x 5	38	G 1/4	11.5	39.5	AOH 3180	HM 3198	HMV 86 E
	400	278	298	Tr 420 x 5	28	G 1/4	9	35	AOH 24180	HM 3188	HMV 88 E
	400	302	312	Tr 440 x 5	44	G 1/4	14	51.4	AOH 3280	HM 3184	HMV 84 E
400	420	186	196	Tr 450 x 5	34	G 1/4	10	29	AOH 3084	HM 90	HMV 90 E
	420	230	252	Tr 440 x 5	30	G 1/4	9	29	AOH 24084	HM 3088	HMV 88 E
	420	266	276	Tr 460 x 5	40	G 1/4	12.5	46	AOH 3184	HM 3192	HMV 92 E
	420	310	332	Tr 440 x 5	30	G 1/4	9	39	AOH 24184	HM 3188	HMV 88 E
	420	321	331	Tr 460 x 5	46	G 1/4	14	59	AOH 3284	HM 3192	HMV 92 E
420	440	194	205	Tr 470 x 5	35	G 1/4	10.5	31.5	AOHX 3088	HM 94	HMV 94 E
	440	242	264	Tr 460 x 5	30	G 1/4	9	32	AOH 24088	HM 92	HMV 92 E
	440	270	281	Tr 480 x 5	42	G 1/4	12.5	50	AOHX 3188	HM 3196	HMV 96 E
	440	310	332	Tr 460 x 5	30	G 1/4	9	45.5	AOH 24188	HM 3192	HMV 92 E
	440	330	341	Tr 480 x 5	48	G 1/4	14.5	64.5	AOHX 3288	HM 3196	HMV 96 E
440	460	202	213	Tr 490 x 5	37	G 1/4	11	35	AOHX 3092	HM 98	HMV 98 E
	460	250	273	Tr 480 x 5	32	G 1/4	9	34.7	AOH 24092	HM 96	HMV 96 E
	460	285	296	Tr 510 x 6	43	G 1/4	13	58	AOHX 3192	HM 102	HMV 102 E
	460	332	355	Tr 480 x 5	32	G 1/4	9	50	AOH 24192	HM 3196	HMV 96 E
	460	349	360	Tr 510 x 6	50	G 1/4	15	75.3	AOHX 3292	HM 102	HMV 102 E
460	480	205	217	Tr 520 x 6	38	G 1/4	11	39.6	AOHX 3096	HM 104	HMV 104 E
	480	250	273	Tr 500 x 5	32	G 1/4	9	36.5	AOH 24096	HM 100	HMV 100 E
	480	295	307	Tr 530 x 6	45	G 1/4	13.5	63	AOHX 3196	HM 31/530	HMV 105 E
	480	340	363	Tr 500 x 5	32	G 1/4	9	51.5	AOH 24196	HM 31/500	HMV 100 E
	480	364	376	Tr 530 x 6	52	G 1/4	15.5	82.5	AOHX 3296	HM 31/530	HMV 106 E
480	500	209	221	Tr 540 x 6	40	G 1/4	11	42.4	AOHX 30/500	HM 108	HMV 108 E
	500	253	276	Tr 530 x 6	35	G 1/4	9	41.7	AOH 240/500	HM 106	HMV 106 E
	500	313	325	Tr 550 x 6	47	G 1/4	14	70.7	AOHX 31/500	HM 110	HMV 110 E
	500	360	383	Tr 530 x 6	35	G 1/4	9	57	AOH 241/500	HM 31/530	HMV 106 E
	500	393	405	Tr 550 x 6	54	G 1/4	9	89.5	AOHX 32/500	HM 110	HMV 110 E

1) Anchura manguito antes del prensado en el agujero interior del rodamiento.
1) Width of taper adapter, before being pressed inside inner bore of bearing.

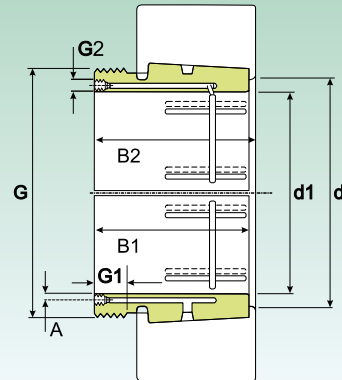
**MANGUITOS DE DESMONTAJE
WITHDRAWAL SLEEVES**

Dimensión Dimension								Peso (kg) Weight (Kg)	Sigla Designation		
d1 (mm)	d (mm)	B1 ¹⁾ (mm)	B2 (mm)	G (mm)	G1 (mm)	G2 (mm)	A (mm)		Manguitos dedesmontaje Withdrawal sleeves	Tuerca para el desmontaje Dismounting nut	Tuerca hidráulica Hydraulic lock nut
500	530	230	242	Tr 560 x 6	45	G 1/4	9	64.5	AOH 30/530	HM 30/560	HMV 112 E
	530	285	309	Tr 550 x 6	35	G 1/4	10	64.5	AOH 240/530	HM 110	HMV 110 E
	530	325	337	Tr 560 x 6	53	G 1/4	10	94.5	AOH 31/530	HM 31/560	HMV 112 E
	530	370	394	Tr 560 x 6	35	G 1/4	9	86	AOH 241/530	HM 110	HMV 110 E
	530	412	424	Tr 560 x 6	35	G 1/4	9	127	AOH 32/530	HM 31/560	HMV 112 E
530	560	240	252	Tr 600 x 6	45	G 1/4	11	73.5	AOHX 30/560	HM 30/600	HMV 120 E
	560	296	320	Tr 600 x 6	55	G 1/4	11	70	AOH 240/560 G	HM 31/600	HMV 120 E
	560	335	347	Tr 600 x 6	57	G 1/4	11	107	AOH 31/560	HM 31/600	HMV 120 E
	560	393	417	Tr 600 x 6	38	G 1/4	9	107	AOH 241/560 G	HM 31/600	HMV 120 E
	560	422	434	Tr 600 x 6	38	G 1/4	9	143	AOHX 32/560	HM 31/600	HMV 120 E
560	600	245	259	Tr 630 x 6	45	G 1/4	11	77	AOH 30/600	HM 30/630	HMV 126 E
	600	310	336	Tr 630 x 6	55	G 1/4	11	86.5	AOH 240/600	HM 31/630	HMV 126 E
	600	355	369	Tr 630 x 6	57	G 1/4	9	120	AOH 31/600	HM 31/630	HMV 126 E
	600	445	459	Tr 630 x 6	38	G 1/4	9	159	AOH 32/600 G	HM 31/630	HMV 126 E
570	600	413	439	Tr 630 x 6	38	G 1/4	11	120	AOHX 241/600	HM 31/630	HMV 126 E
	630	258	272	Tr 670 x 6	46	G 1/4	11	88.5	AOH 30/630	HM 30/670	HMV 134 E
	630	330	356	Tr 670 x 6	60	G 1/4	11	101	AOH 240/630 G	HM 31/670	HMV 134 E
	630	375	389	Tr 670 x 6	63	G 1/4	9	139	AOH 31/630	HM 31/670	HMV 134 E
	630	440	466	Tr 670 x 6	40	G 1/4	9	139	AOH 241/630 G	HM 31/670	HMV 134 E
	630	475	489	Tr 670 x 6	40	G 1/4	9	188	AOH 32/630 G	HM 31/670	HMV 134 E
630	670	280	294	Tr 710 x 7	50	G 1/4	12	125	AOH 30/670	HM 30/710	HMV 142 E
	670	348	374	Tr 710 x 7	59	G 1/4	12	140	AOH 240/670 G	HM 31/710	HMV 142 E
	670	395	409	Tr 710 x 7	62	G 1/4	12	189	AOHX 31/670	HM 31/710	HMV 142 E
	670	452	478	Tr 710 x 7	40	G 1/4	12	180	AOH 241/670	HM 31/710	HMV 142 E
	670	500	514	Tr 710 x 7	40	G 1/4	12	252	AOH 32/670 G	HM 31/710	HMV 142 E
670	710	286	302	Tr 750 x 7	50	G 1/4	15	138	AOHX 30/710	HM 30/750	HMV 150 E
	710	360	386	Tr 750 x 7	60	G 1/4	15	155	AOH 240/710 G	HM 31/750	HMV 150 E
	710	405	421	Tr 750 x 7	65	G 1/4	15	207	AOHX 31/710	HM 31/750	HMV 150 E
	710	483	509	Tr 750 x 7	45	G 1/4	12	205	AOH 241/710	HM 31/750	HMV 150 E
	710	515	531	Tr 750 x 7	45	G 1/4	12	278	AOH 32/710 G	HM 31/750	HMV 150 E
710	750	300	316	Tr 800 x 7	50	G 1/4	15	145	AOH 30/750	HM 30/800	HMV 160 E
	750	380	408	Tr 800 x 7	60	G 1/4	15	178	AOH 240/750 G	HM 31/800	HMV 160 E
	750	425	441	Tr 800 x 7	65	G 1/4	15	238	AOH 31/750	HM 31/800	HMV 160 E
	750	520	548	Tr 800 x 7	45	G 1/4	12	240	AOH 241/750 G	HM 31/800	HMV 160 E
	750	540	556	Tr 800 x 7	45	G 1/4	12	320	AOH 32/750	HM 31/800	HMV 160 E
750	800	308	326	Tr 850 x 7	50	G 1/4	15	204	AOH 30/800	HM 30/850	HMV 170 E
	800	395	423	Tr 850 x 7	63	G 1/4	15	237	AOH 240/800 G	HM 31/850	HMV 170 E
	800	438	456	Tr 850 x 7	67	G 1/4	15	305	AOH 31/800	HM 31/850	HMV 170 E
	800	525	553	Tr 850 x 7	50	G 1/4	15	310	AOH 241/800 G	HM 31/850	HMV 170 E
	800	550	568	Tr 850 x 7	50	G 1/4	15	401	AOH 32/800 G	HM 31/850	HMV 170 E
800	850	325	343	Tr 900 x 7	53	G 1/4	15	230	AOH 30/850	HM 30/900	HMV 180 E
	850	415	445	Tr 900 x 7	62	G 1/4	15	265	AOH 240/850 G	HM 31/900	HMV 180 E
	850	462	480	Tr 900 x 7	70	G 1/4	15	345	AOH 31/850	HM 31/900	HMV 180 E
	850	560	600	Tr 900 x 7	55	G 1/4	15	368	AOH 241/850	HM 31/900	HMV 180 E
	850	585	603	Tr 900 x 7	60	G 1/4	15	461	AOH 32/850	HM 31/900	HMV 180 E

1) Anchura manguito antes del prensado en el agujero interior del rodamiento.
1) Width of taper adapter, before being pressed inside inner bore of bearing.

MANGUITOS DE DESMONTAJE
WITHDRAWAL SLEEVES

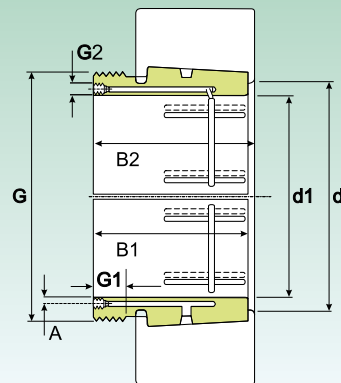

Dimensión Dimension								Peso (kg) Weight (Kg)	Sigla Designation		
d1 (mm)	d (mm)	B1 ¹⁾ (mm)	B2 (mm)	G (mm)	G1 (mm)	G2 (mm)	A (mm)		Manguitos dedesmontaje Withdrawal sleeves	Tuerca para el desmontaje Dismounting nut	Tuerca hidráulica Hydraulic lock nut
850	900	335	355	Tr 950 x 8	55	G 1/4	15	250	AOH 30/900	HM 30/950	HMV 190 E
	900	430	475	Tr 950 x 8	63	G 1/4	15	296	AOH 240/900	HM 31/950	HMV 190 E
	900	475	495	Tr 950 x 8	70	G 1/4	15	379	AOH 31/900	HM 31/950	HMV 190 E
	900	575	620	Tr 950 x 8	55	G 1/4	15	402	AOH 241/900	HM 31/950	HMV 190 E
	900	585	605	Tr 950 x 8	60	G 1/4	15	489	AOH 32/900	HM 31/950	HMV 190 E
900	950	355	375	Tr 1000 x 8	55	G 1/4	15	285	AOH 30/950	HM 30/1000	HMV 200 E
	950	467	512	Tr 1000 x 8	62	G 1/4	15	340	AOH 240/950	HM 31/1000	HMV 200 E
	950	500	520	Tr 1000 x 8	70	G 1/4	15	426	AOH 31/950	HM 31/1000	HMV 200 E
	950	600	620	Tr 1000 x 8	55	G 1/4	15	533	AOH 32/950	HM 31/1000	HMV 200 E
	950	605	650	Tr 1000 x 8	60	G 1/4	15	449	AOH 241/950	HM 31/1000	HMV 200 E
950	1000	365	387	Tr 1060 x 8	57	G 1/4	15	318	AOH 30/1000	HM 30/1060	HMV 212 E
	1000	469	519	Tr 1060 x 8	63	G 1/4	15	369	AOH 240/1000	HM 31/1060	HMV 212 E
	1000	525	547	Tr 1060 x 8	70	G 1/4	15	485	AOH 31/1000	HM 31/1060	HMV 212 E
	1000	630	652	Tr 1060 x 8	57	G 1/4	15	608	AOH 32/1000	HM 31/1060	HMV 212 E
	1000	645	695	Tr 1060 x 8	65	G 1/4	15	519	AOH 241/1000	HM 31/1060	HMV 212 E
1000	1060	385	407	Tr 1120 x 8	60	G 1/4	15	406	AOH 30/1060	HM 30/1120	HMV 224 E
	1060	498	548	Tr 1120 x 8	65	G 1/4	15	479	AOH 240/1060	HM 31/1120	HMV 224 E
	1060	540	562	Tr 1120 x 8	60	G 1/4	15	599	AOH 31/1060	HM 31/1120	HMV 224 E
	1060	665	715	Tr 1120 x 8	65	G 1/4	15	652	AOH 241/1060	HM 31/1120	HMV 224 E

1) Anchura manguito antes del prensado en el agujero interior del rodamiento.
1) Width of taper adapter, before being pressed inside inner bore of bearing.

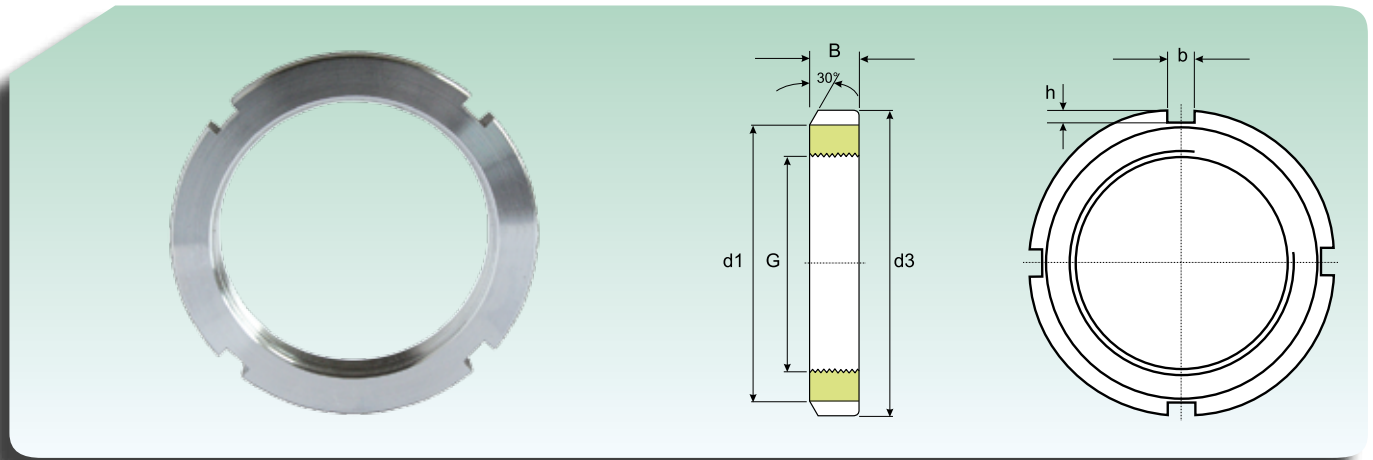
**TUERCAS DE BLOQUEO CON ARANDELA DE SEGURIDAD
LOCK NUTS WITH LOCKING WASHER**

Dimensiones Dimension						Peso (kg) Weight (Kg)	Sigla Designation	
G (mm)	d1 (mm)	d3 (mm)	B (mm)	b (mm)	h (mm)		Tuerca de bloqueo Designation locknut	Arandeleta de seguridad Locking Washer
M 10x0.75	13.5	18	4	3	2	0.004	KM 0	MB 0
M 12x1	17	22	4	3	2	0.006	KM 1	MB 1
M 15x1	21	25	5	4	2	0.009	KM 2	MB 2
M 17x1	24	28	5	4	2	0.015	KM 3	MB 3
M 20x1	26	32	6	4	2	0.025	KM 4	MB 4
M 25x1.5	32	38	7	5	2	0.028	KM 5	MB 5
M 30x1.5	38	45	7	5	2	0.039	KM 6	MB 6
M 35x1.5	44	52	8	5	2	0.059	KM 7	MB 7
M 40x1.5	50	58	9	6	2.5	0.078	KM 8	MB 8
M 45x1.5	56	65	10	6	2.5	0.11	KM 9	MB 9
M 50x1.5	61	70	11	6	2.5	0.14	KM 10	MB 10
M 55x2	67	75	11	7	3	0.15	KM 11	MB 11
M 60x2	73	80	11	7	3	0.16	KM 12	MB 12
M 65x2	79	85	12	7	3	0.19	KM 13	MB 13
M 70x2	85	92	12	8	3.5	0.23	KM 14	MB 14
M 75x2	90	98	13	8	3.5	0.27	KM 15	MB 15
M 80x2	95	105	15	8	3.5	0.36	KM 16	MB 16
M 85x2	102	110	16	8	3.5	0.41	KM 17	MB 17
M 90x2	108	120	16	10	4	0.51	KM 18	MB 18
M 95x2	113	125	17	10	4	0.55	KM 19	MB 19
M 100x2	120	130	18	10	4	0.64	KM 20	MB 20
M 105x2	126	140	18	12	4	0.79	KM 21	MB 21
M 110x2	133	145	19	12	5	0.87	KM 22	MB 22
M 115x2	137	150	19	12	5	0.91	KM 23	MB 23
M 120x2	135	145	20	12	5	0.69	KML 24	MBL 24
M 120x2	138	155	20	12	5	0.97	KM 24	MB 24
M 125x2	148	160	21	12	5	1.09	KM 25	MB 25
M 130x2	145	155	21	12	5	0.8	KML 26	MBL 26
M 130x2	149	165	21	12	5	1.09	KM 26	MB 26
M 135x2	160	175	22	14	6	1.39	KM 27	MB 27
M 140x2	155	165	22	12	5	0.92	KML 28	MBL 28

TUERCAS DE BLOQUEO CON ARANDELA DE SEGURIDAD
LOCK NUTS WITH LOCKING WASHER

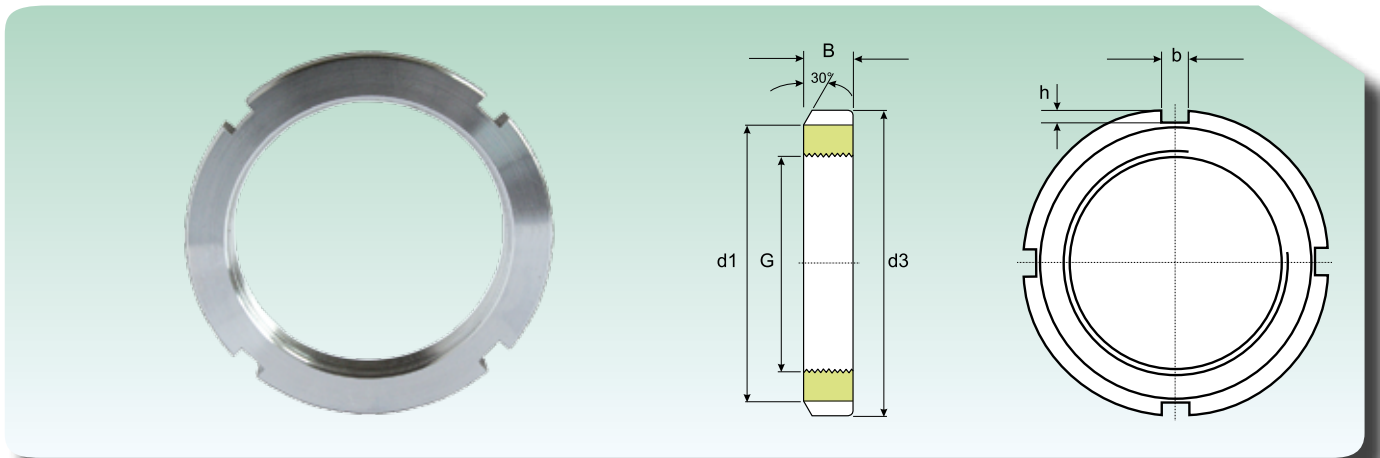

Dimensiones Dimension						Peso (kg) Weight (Kg)	Sigla Designation	
G (mm)	d1 (mm)	d3 (mm)	B (mm)	b (mm)	h (mm)		Tuerca de bloqueo Designation locknut	Arandeleta de seguridad Locking Washer
M 140x2	160	180	22	14	6	1.4	KM 28	MB 28
M 145x2	171	190	24	14	6	1.8	KM 29	MB 29
M 150x2	170	180	24	14	5	1.25	KML 30	MBL 30
M 150x2	171	195	24	14	6	1.88	KM 30	MB 30
M 155x3	182	200	25	16	7	2.09	KM 31	MB 31
M 160x3	180	190	25	14	5	1.39	KML 32	MBL 32
M 160x3	182	210	25	16	7	2.29	KM 32	MB 32
M 165x3	193	210	26	16	7	2.31	KM 33	MB 33
M 170x3	190	200	26	16	5	1.56	KML 34	MBL 34
M 170x3	193	220	26	16	7	2.54	KM 34	MB 34
M 180x3	200	210	27	16	5	1.78	KML 36	MBL 36
M 180x3	203	230	27	18	8	2.78	KM 36	MB 36
M 190x3	210	220	28	16	5	1.84	KML 38	MBL 38
M 190x3	214	240	28	18	8	3.05	KM 38	MB 38
M 200x3	222	240	29	18	8	2.61	KML 40	MBL 40
M 200x3	226	250	29	18	8	3.37	KM 40	MB 40
M 220x4	250	280	32	20	10	5,4	KM 44	MB 44
M 240x4	270	300	34	20	10	6,2	KM 48	MB 48

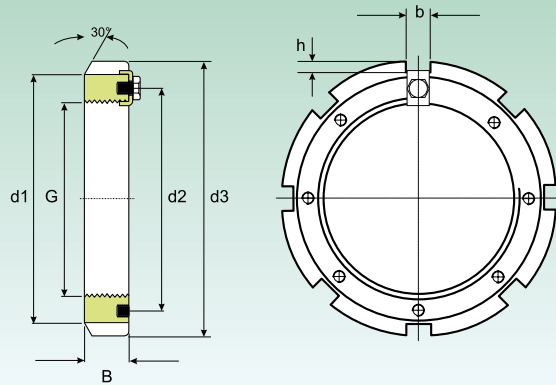
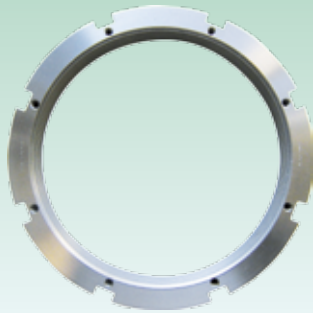
TUERCAS DE BLOQUEO CON GRAPA DE BLOQUEO
LOCK NUTS WITH LOCKING CLIPS

Dimensión Dimension							Peso (Kg) Weight (Kg)	Sigla Designation	
G (mm)	d1 (mm)	d2 (mm)	b (mm)	h (mm)	d3 (mm)	B (mm)		Tuerca Lock nut	Grapa de bloqueo Locking clip
Tr 220x4	242	229	20	9	260	30	2.75	HM 3044	MS 3044
Tr 240x4	270	253	20	10	290	34	4.5	HM 3048	MS 3052-48
	270	253	20	10	290	34	4.5	HME 3048	MS 3052-48
Tr 260x4	290	273	20	10	310	34	4.8	HM 3052	MS 3052-48
Tr 280x4	310	293	24	10	330	38	5.75	HM 3056	MS 3056
Tr 300x4	336	316	24	12	360	42	8.35	HM 3060	MS 3060
	340	326	24	12	380	40	11.5	HM 3160	MS 3160
Tr 320x5	356	336	24	12	380	42	9	HM 3064	MS 3068-64
	360	346	24	12	400	42	13	HM 3164	MS 3164
Tr 340x5	376	356	24	12	400	45	11	HM 3068	MS 3068-64
	400	373	28	15	440	55	24	HM 3168	MS 3172-68
Tr 360x5	394	375	28	13	420	45	11.5	HM 3072	MS 3072
	420	393	28	15	460	58	26.5	HM 3172	MS 3172-68
Tr 380x5	422	399	28	14	450	48	15	HM 3076	MS 3080-76
	440	415	32	18	490	60	32	HM 3176	MS 3176
Tr 400x5	442	419	28	14	470	52	17	HM 3080	MS 3080-76
	460	440	32	18	520	62	38	HM 3180	MS 3184-80
Tr 420x5	462	439	32	14	490	52	18.5	HM 3084	MS 3084
	462	439	32	14	490	52	18.5	HME 3084	MS 3084
	490	460	32	18	540	70	45	HM 3184	MS 3184-80
Tr 440x5	490	463	32	15	520	60	26	HM 3088	MS 3092-88
	510	478	36	20	560	70	46.5	HM 3188	MS 3192-88
Tr 460x5	510	483	32	15	540	60	27	HM 3092	MS 3092-88
	540	498	36	20	580	75	50.5	HM 3192	MS 3192-88
Tr 480x5	530	503	36	15	560	60	28	HM 3096	MS 30/500-96
	560	528	36	20	620	75	62	HM 3196	MS 3196
Tr 500x5	550	523	36	15	580	68	33.5	HM 30/500	MS 30/500-96
	550	523	36	15	580	68	33.5	HME 30/500	MS 30/500-96
	580	540	40	23	630	80	63.5	HM 31/500	MS 31/500
Tr 530x6	590	558	40	20	630	68	42.5	HM 30/530	MS 30/530
	610	575	40	23	670	80	71.5	HM 31/530	MS 31/600-530
Tr 560x6	610	583	40	20	650	75	44.5	HM 30/560	MS 30/560
	610	583	40	20	650	75	44.5	HME 30/560	MS 30/560
	650	608	45	25	710	85	86.5	HM 31/560	MS 31/600-560
Tr 300x4	660	628	45	20	700	75	52.5	HM 30/600	MS 30/600-530
	660	628	45	20	700	75	52.5	HME 30/600	MS 30/600-530
	690	648	50	25	750	85	91.5	HM 31/600	MS 31/600-560
Tr 630x6	690	658	45	20	730	75	55	HM 30/630	MS 30/630
	730	685	50	28	800	95	125	HM 31/630	MS 31/630

TUERCAS DE BLOQUEO CON GRAPA DE BLOQUEO
LOCK NUTS WITH LOCKING CLIPS

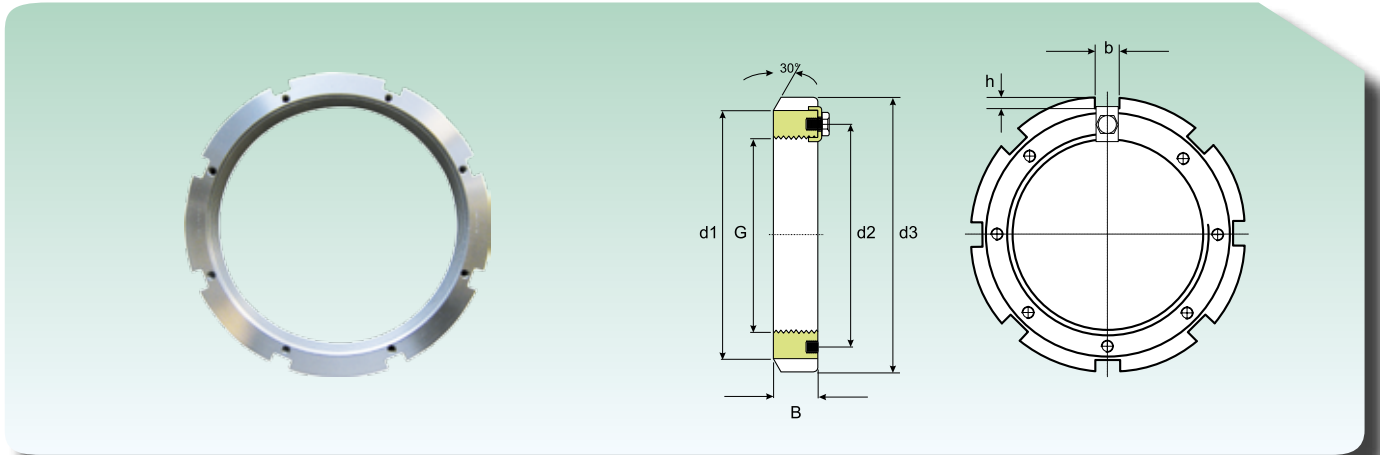

Dimensión Dimension							Peso (Kg) Weight (Kg)	Sigla Designation	
G (mm)	d1 (mm)	d2 (mm)	b (mm)	h (mm)	d3 (mm)	B (mm)		Tuerca Lock nut	Grapa de bloqueo Locking clip
Tr 670x6	740	703	50	20	780	80	68.5	HM 30/670	MS 30/670
	775	730	45	28	850	106	155	HM 31/670	MS 31/670
Tr 710x7	780	742	50	25	830	90	91.5	HM 30/710	MS 30/710
	780	742	50	25	830	90	91.5	HME 30/710	MS 30/710
	825	772	55	30	900	106	162	HM 31/710	MS 31/710
Tr 750x7	820	782	55	25	870	90	94	HM 30/750	MS 30/800-750
	820	782	55	25	870	90	94	HME 30/750	MS 30/800-750
	875	813	60	34	950	112	190	HM 31/750	MS 31/800-750
Tr 800x7	870	832	55	25	920	90	99.5	HM 30/800	MS 30/800-750
	925	863	60	34	1000	112	202	HM 31/800	MS 31/800-750
Tr 850x7	925	887	60	25	980	90	115	HM 30/850	MS 30/900-850
	925	887	60	25	980	90	110	HME 30/850	MS 30/900-850
	975	914	70	38	1060	118	234	HM 31/850	MS 31/850
Tr 900x7	975	937	60	25	1030	100	131	HM 30/900	MS 30/900-850
	1030	969	70	38	1120	125	279	HM 31/900	MS 31/900
Tr 950x8	1025	985	60	25	1080	100	139	HM 30/950	MS 30/950
	1080	1017	70	38	1170	125	293	HM 31/950	MS 31/950
Tr 1000x8	1085	1040	60	25	1140	100	157	HM 30/1000	MS 30/1000
	1140	1077	70	38	1240	125	336	HM 31/1000	MS 31/1000
Tr 1060x8	1145	1100	60	25	1200	100	166	HM 30/1060	MS 30/1000
	1210	1137	70	38	1300	125	354	HM 31/1060	MS 31/1000
Tr 1120x8	1205	1160	60	25	1260	100	175	HM 30/1120	MS 30/1000

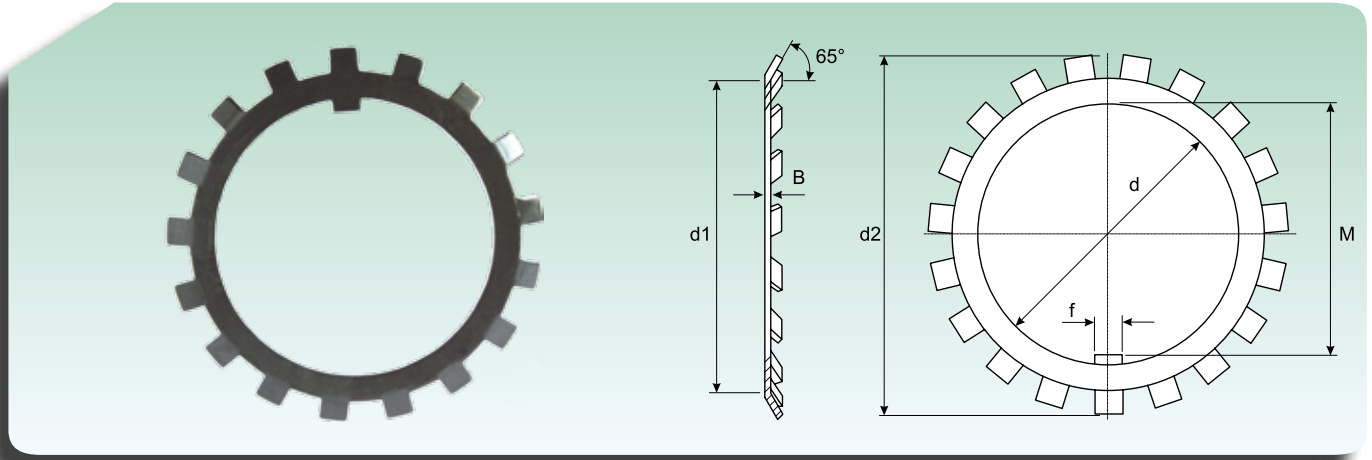
**ARANDELA DE SEGURIDAD
LOCKING WASHER**

Dimensiones Dimension						Peso (Kg) Weight (Kg)	Sigla Designation
d (mm)	d1 (mm)	d2 (mm)	B (mm)	f (mm)	M (mm)		
10	13.5	21	1	3	8.5	0.001	MB 0
12	17	25	1	3	10.5	0.002	MB 1
15	21	28	1	4	13.5	0.003	MB 2
17	24	32	1	4	15.5	0.003	MB 3
20	26	36	1	4	18.5	0.004	MB 4
25	32	42	1.25	5	23	0.006	MB 5
30	38	49	1.25	5	27.5	0.008	MB 6
35	44	57	1.25	6	32.5	0.011	MB 7
40	50	62	1.25	6	37.5	0.013	MB 8
45	56	69	1.25	6	42.5	0.015	MB 9
50	61	74	1.25	6	47.5	0.016	MB 10
55	67	81	1.5	8	52.5	0.022	MB 11
60	73	86	1.5	8	57.5	0.024	MB 12
65	79	92	1.5	8	62.5	0.03	MB 13
70	85	98	1.5	8	66.5	0.032	MB 14
75	90	104	1.5	8	71.5	0.035	MB 15
80	95	112	1.75	10	76.5	0.046	MB 16
85	102	119	1.75	10	81.5	0.053	MB 17
90	108	126	1.75	10	86.5	0.061	MB 18
95	113	133	1.75	10	91.5	0.066	MB 19
100	120	142	1.75	12	96.5	0.077	MB 20
105	126	145	1.75	12	100.5	0.083	MB 21
110	133	154	1.75	12	105.5	0.091	MB 22
115	137	159	2	12	110.5	0.11	MB 23
120	138	164	2	14	115	0.11	MB 24
125	148	170	2	14	120	0.12	MB 25
130	149	175	2	14	125	0.12	MB 26
135	160	185	2	14	130	0.14	MB 27
140	160	192	2	16	135	0.14	MB 28
145	172	202	2	16	140	0.17	MB 29
150	170	205	2	16	145	0.18	MB 30

ARANDELA DE SEGURIDAD LOCKING WASHER

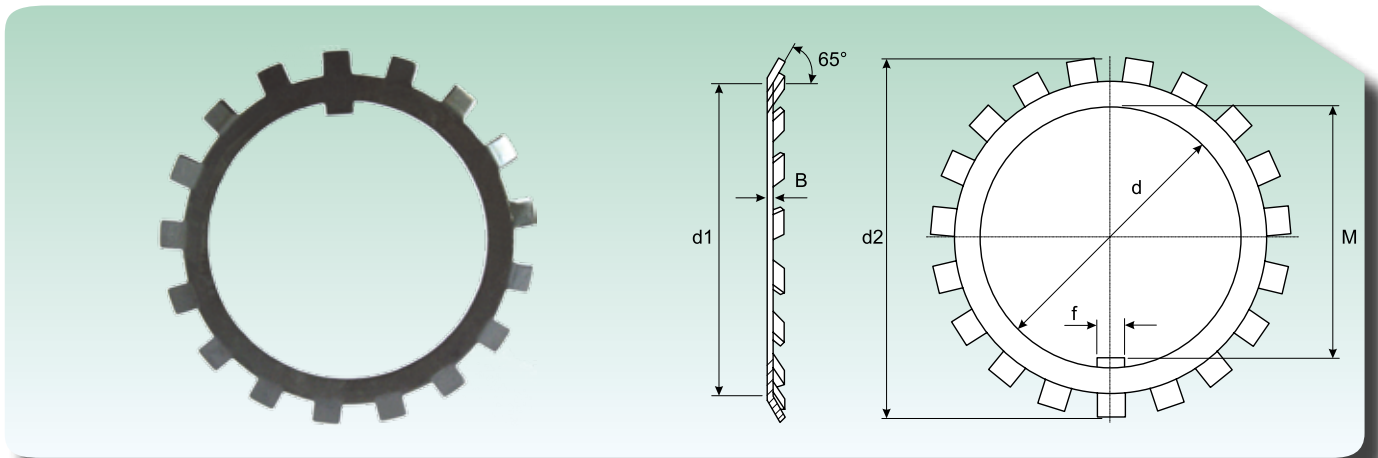

Dimensiones Dimension						Peso (Kg) Weight (Kg)	Sigla Designation
d (mm)	d1 (mm)	d2 (mm)	B (mm)	f (mm)	M (mm)		
155	182	212	2.5	16	147.5	0.20	MB 31
160	182	217	2.5	18	154	0.22	MB 32
165	193	222	2.5	18	157.5	0.24	MB 33
170	193	232	2.5	18	164	0.24	MB 34
180	203	242	2.5	20	174	0.26	MB 36
190	214	252	2,5	20	184	0,26	MB 38
200	226	262	2,5	20	194	0,28	MB 40
220	250	292	3	24	213	0,35	MB 44
240	270	312	3	24	233	0,45	MB 48
260	300	342	3	28	253	0,65	MB 52
280	320	362	3	28	273	0,74	MB 56

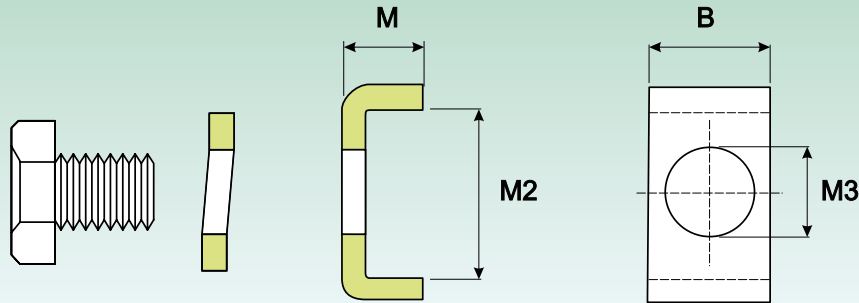
**GRAPAS DE BLOQUEO
LOCKING CLIPS**

Dimensiones Dimension				Peso (Kg) Weight (Kg)	Sigla Designation			
B (mm)	M (mm)	M2 (mm)	M3 (mm)		Grapa de bloqueo Locking clips	Tornillo Screw	Arandela Washer	Tuerca idónea Adapt lock nuts
20	12	13.5	0.022	7	MS 3044	M 6x12	A 6	HM 3044
	12	17.5	0.024	9	MS 3052-48	M 8x16	A 8	HM 3048
24	12	17.5	0.03	9	MS 3056	M 8x16	A 8	HM 3056
	12	20.5	0.033	9	MS 3060	M 8x16	A 8	HM 3060
	12	30.5	0.04	12	MS 3160	M 10x20	A 10	HM 3160
	15	21	0.046	9	MS 3068-64	M 8x16	A 8	HM 3064
	15	31	0.055	12	MS 3164	M 10x20	A 10	HM 3164
28	15	20	0.051	9	MS 3072	M 8x16	A 8	HM 3072
	15	24	0.055	12	MS 3080-76	M 10x20	A 10	HM 3076
	15	38	0.069	14	MS 3172-68	M 12x25	A 12	HM 3168
32	15	24	0.063	12	MS 3084	M 10x20	A 10	HM 3084
	15	28	0.067	14	MS 3092-88	M 12x25	A 12	HM 3088
	15	40	0.083	14	MS 3176	M 12x25	A 12	HM 3176
	15	45	0.089	18	MS 3184-80	M 16x30	A 16	HM 3180
36	15	28	0.076	14	MS 30/500-96	M 12x25	A 12	HM 3096
	15	43	0.097	18	MS 3192-88	M 16x30	A 16	HM 3188
	15	53	0.11	18	MS 3196	M 16x30	A 16	HM 3196
40	15	45	0.11	18	MS 31/500	M 16x30	A 16	HM 31/500
	21	29	0.15	18	MS 30/560	M 16x30	A 16	HM 30/560
	21	34	0.14	18	MS 30/600-530	M 16x30	A 16	HM 30/530
	21	51	0.19	22	MS 31/530	M 20x40	A 20	HM 31/530
45	21	34	0.17	18	MS 30/630	M 16x30	A 16	HM 30/630
	21	39	0.19	18	MS 30/670	M 16x30	A 16	HM 30/670
	21	54	0.22	22	MS 31/600-560	M 20x40	A 20	HM 31/560
50	21	39	0.21	18	MS 30/710	M 16x30	A 16	HM 30/710
	21	61	0.27	22	MS 31/630	M 20x40	A 20	HM 31/630
	21	66	0.28	22	MS 31/670	M 20x40	A 20	HM 31/670
55	21	39	0.23	18	MS 30/800-750	M 16x30	A 16	HM 30/750
	21	69	0.32	26	MS 31/710	M 24x50	A 24	HM 31/710
60	21	44	0.26	22	MS 30/900-850	M 20x40	A 20	HM 30/850
	21	46	0.28	22	MS 30/950	M 20x40	A 20	HM 30/950
	21	51	0.3	22	MS 30/1000	M 20x40	A 20	HM 30/1000
	21	70	0.35	26	MS 31/800-750	M 24x50	A 24	HM 31/750
70	21	71	0.41	26	MS 31/850	M 24x50	A 24	HM 31/850
	21	78	0.43	26	MS 31/950	M 24x50	A 24	HM 31/950
	21	88	0.45	26	MS 31/1000	M 24x50	A 24	HM 31/1000

TUERCAS AUTOBLOQUEANTES, TIPO NORMAL

SELF-LOCK NUTS, NORMAL TYPE

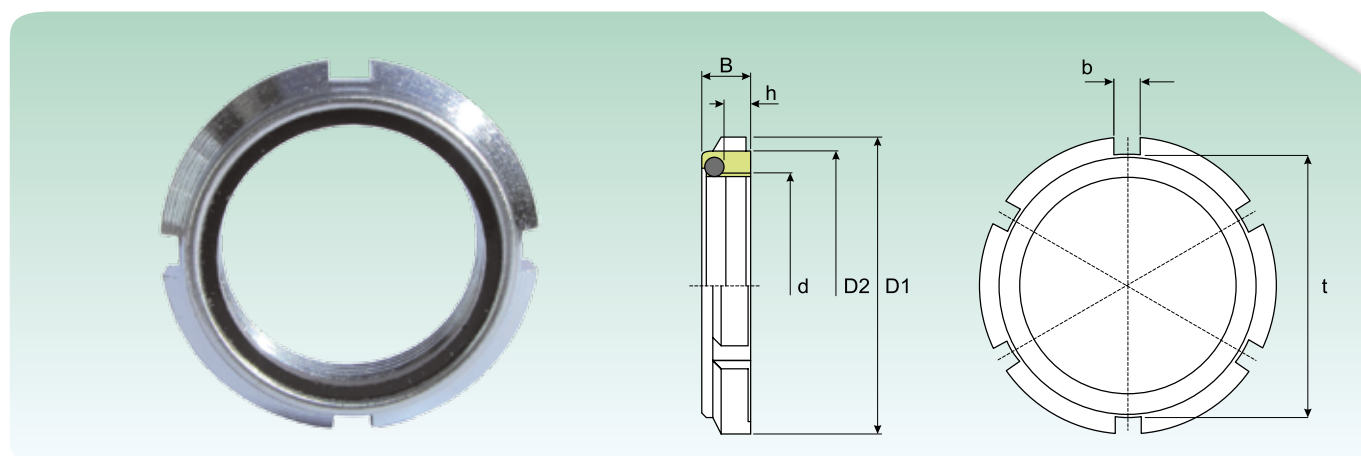

Dimensión Dimension						Roscado Screw	Sigla Designation
B (mm)	h (mm)	D1 (mm)	D2 (mm)	b (mm)	t (mm)		
7.6	4.4	18	14	3	14	M10x0.75	GTN010
7.6	4.4	21	18	3	18	M 12 x 1	GTN012
8.6	5.2	24	21	4	21	M 15 x 1	GTN015
8.6	5.2	28	24	4	24	M17x1	GTN017
9.6	6	32	27	4	27	M 20 x 1	GTN020
10.5	6	38	33	5	33	M 25 x 1.5	GTN025
10.7	6.6	44	38	5	38	M 30 x 1.5	GTN030
11.3	6.6	50	44	5	44	M 35 x 1.5	GTN035
12.3	7.5	56	50	6	50	M 40 x 1.5	GTN040
12.3	7.5	62	55	6	55	M 45 x 1.5	GTN045
12.9	7.6	68	61	6	61	M 50 x 1.5	GTN050
13.4	7.6	75	68	7	68	M 55 x2	GTN055
13.4	7.6	80	73	7	73	M 60 x 2	GTN060
14.5	8.7	85	78	7	78	M 65 x2	GTN065
14.5	8.7	92	84	8	84	M 70 x 2	GTN070
15.5	9.7	98	90	8	90	M 75 x 2	GTN075
16.5	10.7	105	97	8	97	M 80 x 2	GTN080
17.5	11.7	110	102	8	102	M 85 x 2	GTN085
17.7	11.9	120	110	10	110	M 90 x 2	GTN090
18.7	12.9	125	116	10	116	M 95 x 2	GTN095
19.7	13.9	130	120	10	120	M 100 x 2	GTN100

* Tipo de acero y clase de resistencia/resistencia a la tracción: 14H
Tratamientos superficiales: cincado blanco

Material del inserto: Nylon

* Type of steel and strength class/strength to traction: 14 H
Surface treatment: white galvanization

Insert material: Nylon

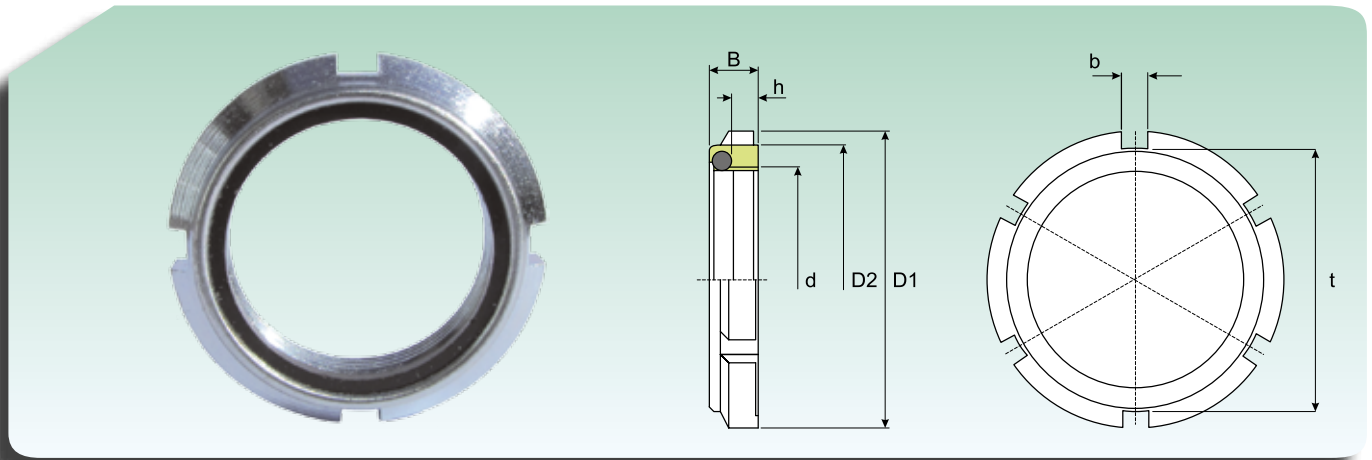
TUERCAS AUTOBLOQUEANTES, TIPO PESADA
SELF-LOCK NUTS, HEAVY TYPE

B (mm)	h (mm)	Dimensión Dimension		b (mm)	t (mm)	Roscado Screw	Sigla Designation
		D1 (mm)	D2 (mm)				
13.2	9.6	32	27	4	27	M 20 x 1	GTP020
14.2	10	38	33	5	33	M 25 x 1.5	GTP025
14.2	10	44	38	5	38	M 30 x 1.5	GTP030
15.5	10.6	50	44	5	44	M 35 x 1.5	GTP035
16.7	11.9	56	50	6	50	M 40 x 1.5	GTP040
16.7	11.9	62	55	6	55	M 45 x 1.5	GTP045
18.7	12.9	68	61	6	61	M 50 x 1.5	GTP050
18.7	12.9	75	68	7	68	M55x2	GTP055
18.7	12.9	80	73	7	73	M 60 x 2	GTP060
19.7	13.9	85	78	7	78	M 65 x 2	GTP065
19.7	13.9	92	84	8	84	M 70 x 2	GTP070
20.7	14.9	98	90	8	90	M 75 x 2	GTP075
20.7	14.9	105	97	8	97	M80x2	GTP080
21.7	15.9	110	102	8	102	M85x2	GTP085
21.7	15.9	120	110	10	110	M 90 x 2	GTP090
22.2	17.1	125	116	10	116	M 95 x 2	GTP095
24.2	18.4	130	120	10	120	M 100 x 2	GTP100

TUERCA YSF BLOQUEO LATERAL
LOCK NUT YSF SIDE LOCKING

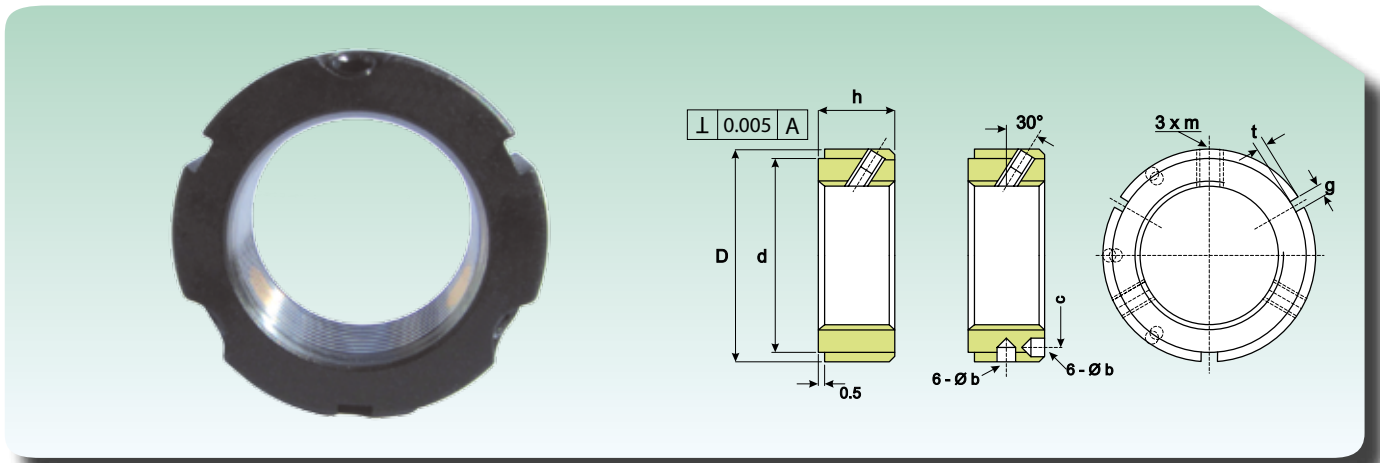

D (mm)	Dimensiones Dimension					Par máximo (Nm) Max Torque (Nm)	Peso (Kg) Weight (Kg)	Sigla Designation	
	h (mm)	d (mm)	g/b	t/c	m				
32	16	27	4/-	2	-	M5	4.5	0.07	YSF M 17X1
38	16	33	4/-	2	-	M5	4.5	0.1	YSF M 20X1
	16	33	4/-	2	-	M6	8	0.1	YSF M 20X1.5
	18	33	5/-	2	-	M6	8	0.09*	YSF M 25X1.5
45	18	40	5/-	2	-	M6	8	0.13	YSF M 30X1.5
52	18	47	5/-	2	-	M8	18	0.17	YSF M 35X1.5
58	20	52	6/-	2.5	-	M8	18	0.22	YSF M 40X 1.5
65	20	59	6/-	2.5	-	M8	18	0.27	YSF M 45X1.5
70	20	64	6/	2.5	-	M8	18	0.31	YSF M 50X1.5
75	22	68	7/Ø6	2.5	65	M8	18	0.36	YSF M 55X2
80	22	73	7/Ø6	2.5	70	M8	18	0.39	YSF M 60X2
85	22	78	7/Ø6	2.5	75	M8	18	0.43	YSF M 65X2
92	24	84	8/Ø7	3	81	M8	18	0.55	YSF M 70X2
98	24	90	8/Ø7	3	87	M8	18	0.62	YSF M 75X2
105	24	96	8/Ø7	3	93	M8	18	0.71	YSF M 80X2
110	24	102	8/Ø7	3	98	M8	18	0.74	YSF M 85X2
120	26	108	10/Ø7	3	105	M8	18	1.02	YSF M 90X2
125	26	113	10/Ø7	3	110	M8	18	1.08	YSF M 95X2
130	26	118	10/Ø7	3	115	M8	18	1.1	YSF M 100X2
140	28	125	10/Ø7	3	123	M 10	35	1.48	YSF M 105X2
145	28	132	10/Ø7	3	128	M 10	35	1.57	YSF M 110X2
150	28	137	10/Ø7	3	133	M 10	35	1.6	YSF M 115X2
155	30	142	12/Ø7	3	138	M 10	35	1.76	YSF M 120X2
160	30	147	12/Ø7	3	143	M10	35	1.82	YSF M 125X2
165	30	152	12/ Ø 7	3	148	M 10	35	1.89	YSF M 130X2
175	32	160	12/Ø7	3.5	155	M10	35	2.46	YSF M 135X2
180	32	165	12/ Ø 7	3.5	160	M 10	35	2.47	YSF M 140X2
190	32	175	12/Ø7	3.5	168	M10	35	2.96	YSF M 145X2
195	32	180	12/Ø7	3.5	173	M 10	35	3.02	YSF M 150X2
200	34	180	14/ Ø 8	3.5	178	M 10	35	3.32	YSF M 155X3
210	34	190	14/ Ø 8	3.5	185	M10	35	3.88	YSF M 160X3
	34	190	14/ Ø 8	3.5	188	M 10	35	3.96	YSF M 165X3

* El peso es correcto
* The weight is correct

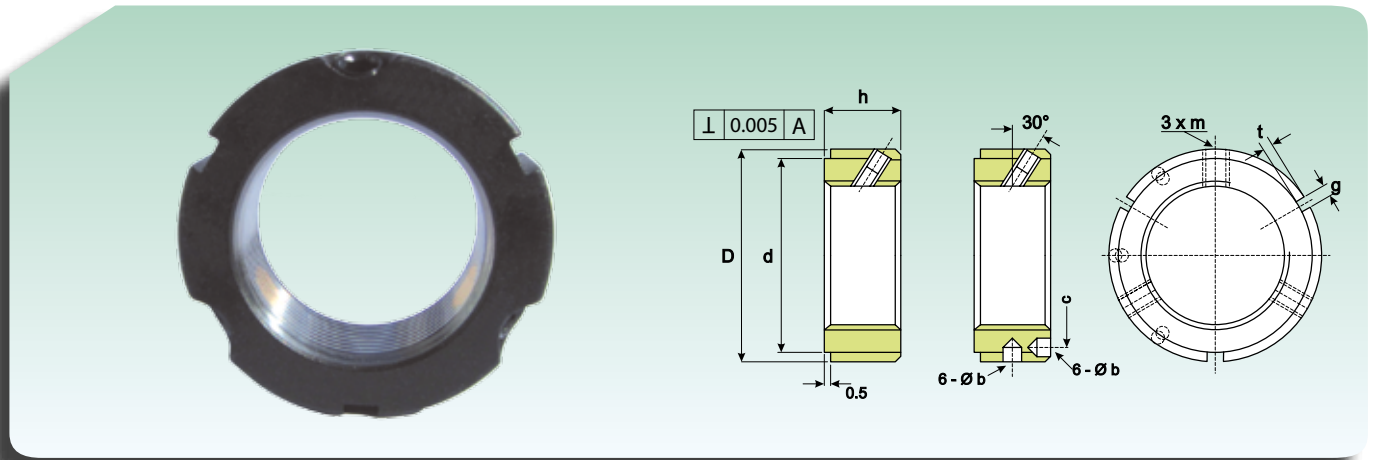
TUERCA YSF BLOQUEO LATERAL
LOCK NUT YSF SIDE LOCKING

D (mm)	h (mm)	d (mm)	Dimensiones Dimension			m	Par máximo (Nm) Max Torque (Nm)	Peso (Kg) Weight (Kg)	Sigla Designation
			g/b	t/c					
220	34	200	14/Ø 8	3.5	195	M 10	35	4.04	YSF M 170X3
230	36	205	16/Ø 8	3.5	205	M 12	60	4.4	YSF M 180X3
240	36	215	16/Ø 8	3.5	215	M 12	60	4.77	YSF M 190X3
250	38	225	16/Ø 8	3.5	225	M 12	60	5.26	YSF M 200X3

TUERCA YSA BLOQUEO AXIAL
LOCK NUT YSA AXIAL LOCKING

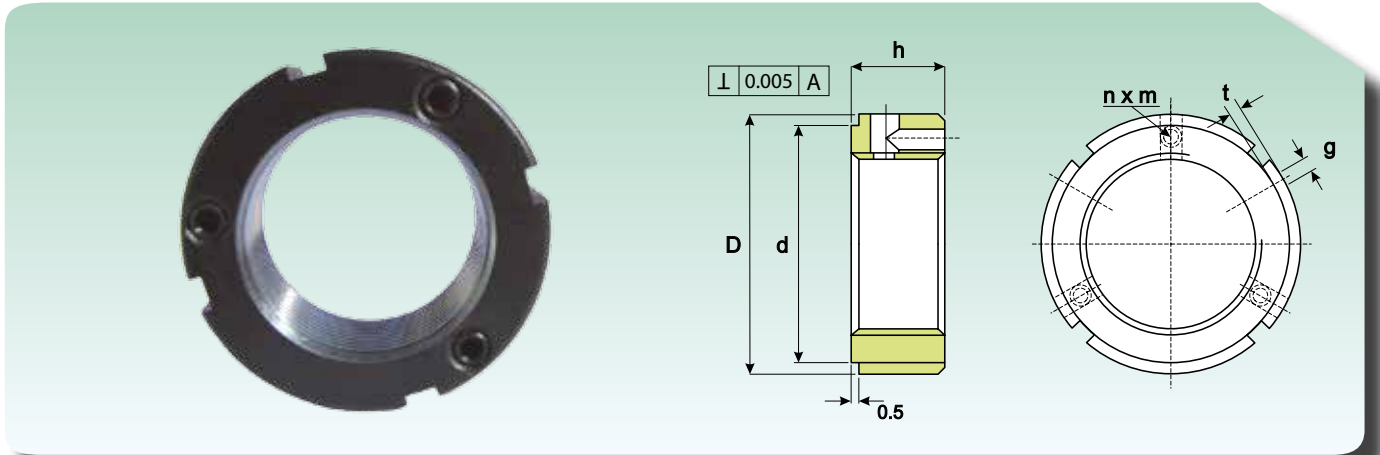

Dimensiones Dimension						Par máximo (Nm) Max Torque (Nm)	Peso (Kg) Weight (Kg)	Sigla Designation
D (mm)	h (mm)	g (mm)	t (mm)	d (mm)	n X m			
32	16	4	2	27	2XM4	3.5	0.07	YSA M 17X1
38	16	4	2	33	3XM4	4.5	0.1	YSAM 20X1
	16	4	2	33	3XM4	4.5	0.1	YSA M 20X1.5
	18	5	2	33	3XM4	4.5	0.09*	YSA M 25X1.5
45	18	5	2	40	3 XM4	4.5	0.13	YSA M 30X1.5
52	18	5	2	47	3XM6	8	0.17	YSA M 35X1.5
58	20	6	2.5	52	3XM6	8	0.22	YSA M 40X1.5
65	20	6	2.5	59	3XM6	8	0.27	YSA M 45X1.5
70	20	6	2.5	64	3XM6	8	0.31	YSA M 50X1.5
75	22	7	3	68	3XM6	8	0.36	YSA M 55X2
80	22	7	3	73	3XM6	8	0.39	YSA M 60X2
85	22	7	3	78	3 XM6	8	0.43	YSAM 65X2
92	24	8	3.5	84	3 XM8	18	0.55	YSA M 70X2
98	24	8	3.5	90	3 XM8	18	0.62	YSAM 75X2
105	24	8	3.5	96	3XM8	18	0.71	YSA M 80X2
110	24	8	3.5	102	3XM 8	18	0.74	YSA M 85X2
120	26	10	4	108	3XM8	18	1.02	YSAM 90X2
125	26	10	4	113	3XM8	18	1.08	YSA M 95X2
130	26	10	4	118	3 XM8	18	1.1	YSA M 100X2
140	28	12	5	125	3XM 10	35	1.48	YSA M 105X2
145	28	12	5	132	3 XM 10	35	1.57	YSA M 110X2
150	28	12	5	137	3XM 10	35	1.6	YSA M 115X2
155	30	12	5	142	3XM 10	35	1.76	YSA M 120X2
160	30	12	5	147	3 XM 10	35	1.82	YSA M 125X2
165	30	12	5	152	3 XM 10	35	1.89	YSA M 130X2
175	32	14	6	160	3XM 12	35	2.46	YSA M 135X2
180	32	14	6	165	3XM 12	35	2.47	YSA M 140X2
190	32	14	6	175	3XM 12	35	2.96	YSA M 145X2
195	32	14	6	180	3 XM 12	35	3.02	YSA M 150X2
200	34	16	7	180	3 XM 12	35	3.32	YSA M 155X3
	34	16	7	190	3XM 12	35	3.88	YSA M 160X3
210	34	16	7	190	3XM 12	35	3.88	YSA M 160X3
	34	16	7	190	3XM 12	35	3.96	YSA M 165X3

* El peso es correcto
* The weight is correct

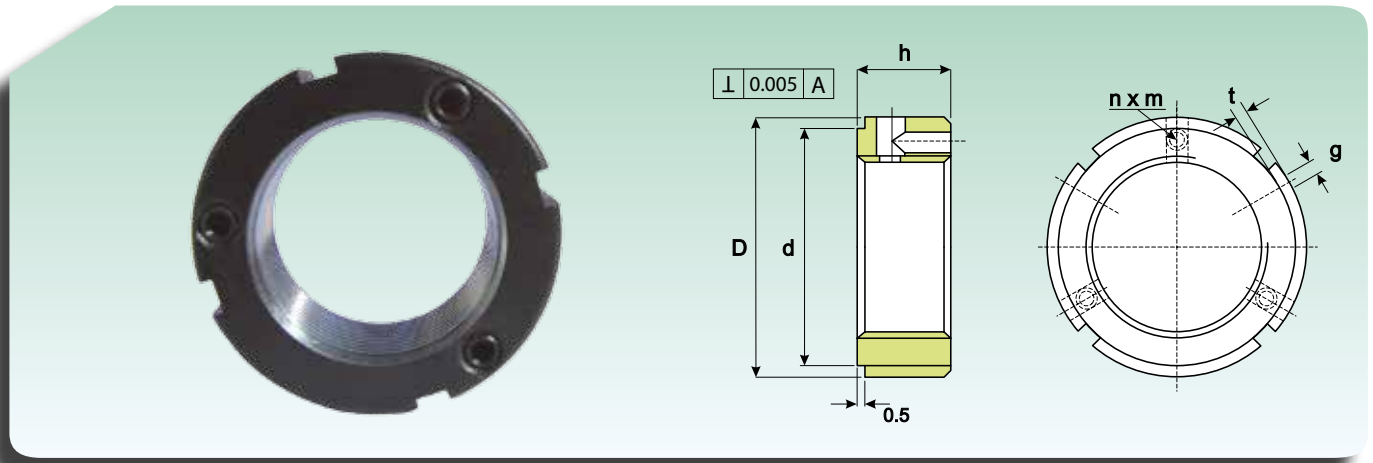
**TUERCA YSA BLOQUEO AXIAL
LOCK NUT YSA AXIAL LOCKING**

Dimensiones Dimension						Par máximo (Nm) Max Torque (Nm)	Peso (Kg) Weight (Kg)	Sigla Designation
D (mm)	h (mm)	g (mm)	t (mm)	d (mm)	n X m			
220	34	16	7	200	3XM 12	35	4.04	YSA M 170X3
230	36	18	8	205	3XM 12	60	4.4	YSA M 180X3
240	36	18	8	215	3XM 12	60	4.77	YSA M 190X3
250	38	18	8	225	3XM 12	60	5.26	YSAM 200X3

* El peso es correcto
* The weight is correct

TUERCA YSR BLOQUEO RADIAL
LOCK NUT YSR RADIAL LOCKING

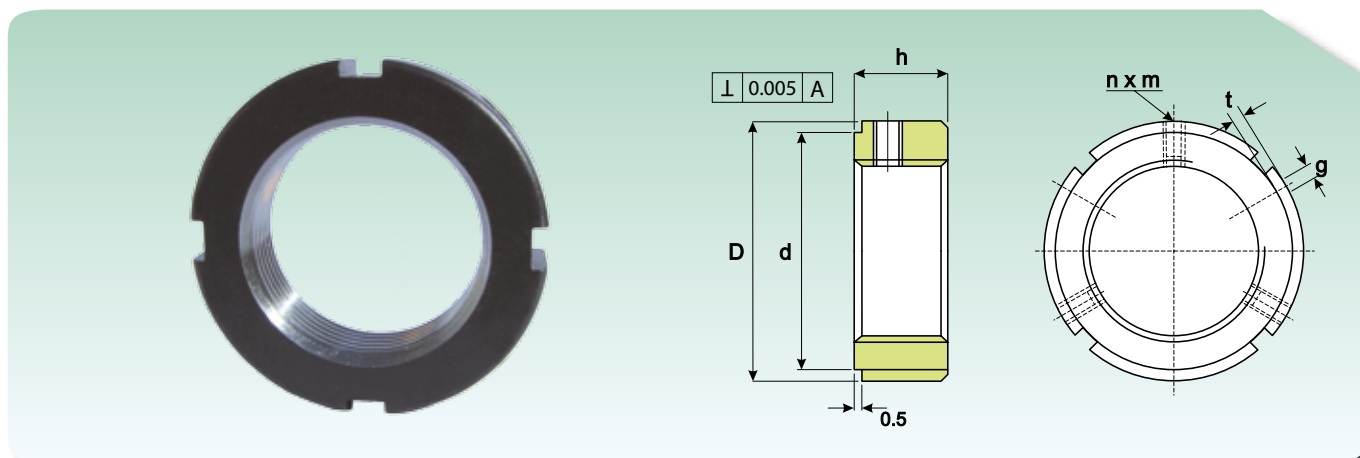

Dimensiones Dimension						Par máximo (Nm) Max Torque (Nm)	Peso (Kg) Weight (Kg)	Sigla Designation
D (mm)	h (mm)	g (mm)	t (mm)	d (mm)	n X m			
16	8	3	2	11	2XM4	4.5	0.015	YSR M 8X0.75
18	8	3	2	13	2XM4	4.5	0.02	YSR M 10X0.75
20	8	3	2	16	2XM4	4.5	0.02	YSR M 12X1
25	8	3	2	21	2XM4	4.5	0.025	YSR M 15X1
28	10	4	2	23	2XM5	8	0.03	YSR M 17X1
32	10	4	2	27	2XM5	8	0.04	YSRM 20X1
	10	4	2	33	2XM5	8	0.04	YSR M 20X1.5
38	12	5	2	33	3XM6	8	0.055	YSR M 25X1.5
45	12	5	2	40	3XM6	8	0.08	YSR M 30X1.5
52	12	5	2	47	3XM6	18	0.12	YSR M 35X1.5
58	14	6	2.5	52	3XM6	18	0.15	YSR M 40X1.5
65	14	6	2.5	59	3XM6	18	0.19	YSRM 45X1.5
70	14	6	2.5	64	3XM6	18	0.22	YSRM 50X1.5
75	16	7	3	68	3XM8	18	0.27	YSRM 55X2
80	16	7	3	73	3XM8	18	0.3	YSR M 60X2
85	16	7	3	78	3XM8	18	0.31	YSRM 65X2
92	18	8	3.5	84	3XM8	18	0.41	YSR M 70X2
98	18	8	3.5	90	3XM8	18	0.47	YSRM 75X2
105	18	8	3.5	96	3XM8	18	0.53	YSRM 80X2
110	18	8	3.5	102	3XM8	18	0.58	YSR M 85X2
120	20	10	4	108	3XM8	18	0.82	YSRM 90X2
125	20	10	4	113	3XM8	18	0.86	YSR M 95X2
130	20	10	4	118	3XM8	18	0.89	YSR M 100X2
140	22	10	5	125	3XM8	35	1.19	YSRM 105X2
145	22	12	5	132	3XM8	35	1.23	YSRM 110X2
150	22	12	5	137	3XM8	35	1.27	YSRM 115X2
155	24	12	5	142	3XM8	35	1.45	YSR M 120X2
160	24	12	5	147	3XM8	35	1.49	YSRM 125X2
165	24	12	5	152	3XM8	35	1.54	YSR M 130X2
175	26	14	6	160	3XM10	35	1.99	YSRM 135X2
180	26	14	6	165	3XM10	35	2.06	YSRM 140X2

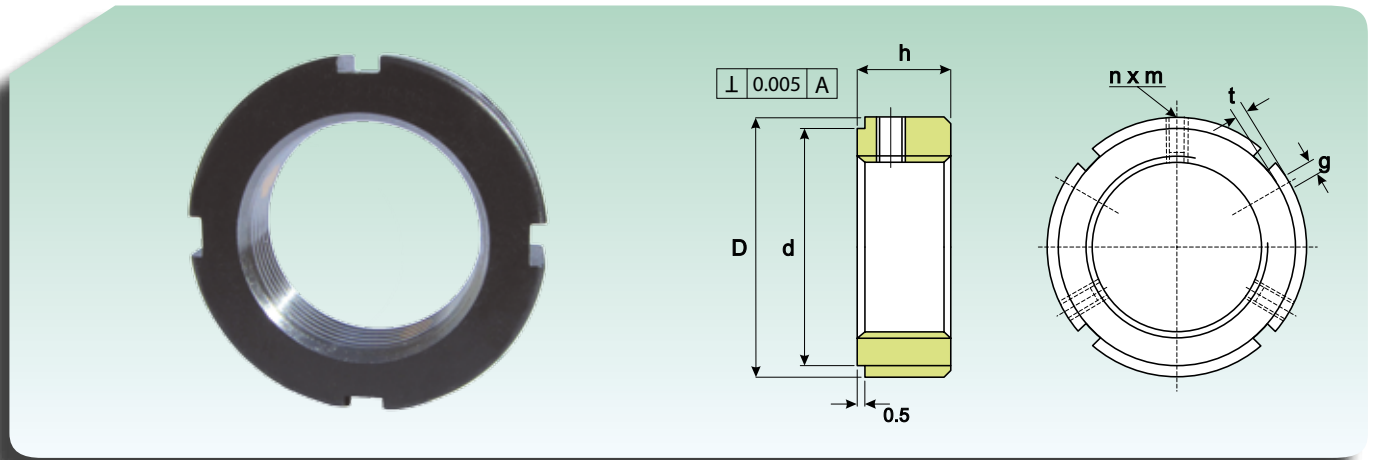
TUERCA YSR BLOQUEO RADIAL
LOCK NUT YSR RADIAL LOCKING

D (mm)	Dimensiones Dimension					Par máximo (Nm) Max Torque (Nm)	Peso (Kg) Weight (Kg)	Sigla Designation
	h (mm)	g (mm)	t (mm)	d (mm)	n X m			
190	26	14	6	175	3XM10	35	2.44	YSRM 145X2
195	26	14	6	180	3XM10	35	2.51	YSR M 150X2
200	28	16	7	180	3XM10	35	2.76	YSRM 155X3
210	28	16	7	190	3XM10	35	3.25	YSR M 160X3
	28	16	7	190	3XM10	35	3.35	YSR M 165X3
220	28	16	7	200	3XM10	35	3.4	YSR M 170X3
230	30	18	8	205	3XM12	60	3.78	YSR M 180X3
240	30	18	8	215	3XM12	60	4	YSR M 190X3
250	32	18	8	225	3XM12	60	4.49	YSR M 200X3

TUERCA YSK BLOQUEO CON RANURADO ELÁSTICO
LOCK NUT YSK LOCKING BY ELASTIC INCISION

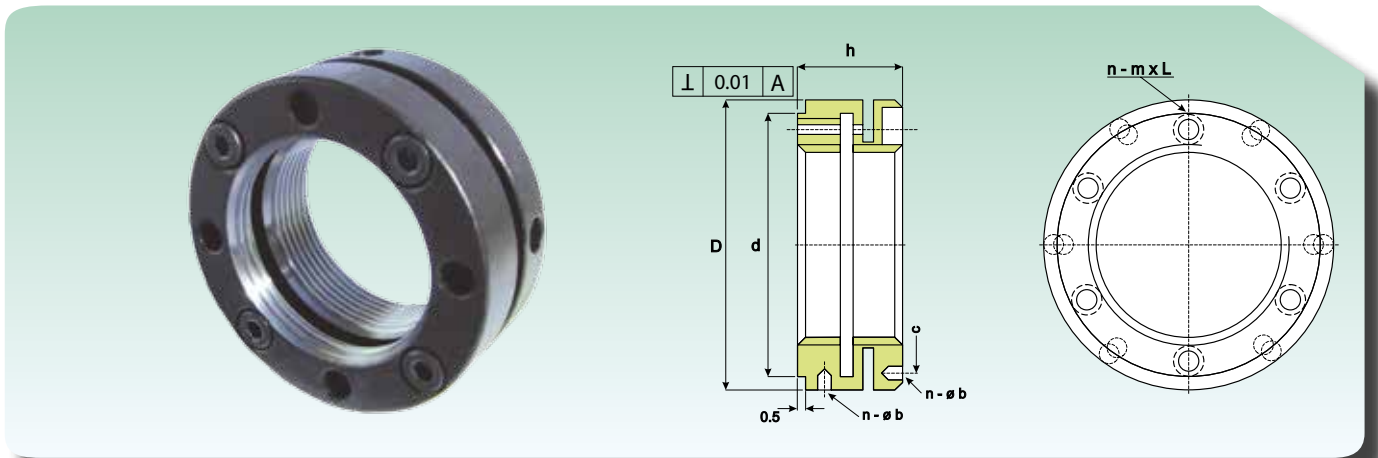

D (mm)	h (mm)	Dimensión Dimension				Peso (Kg) Weight (Kg)	Sigla Designation
		d (mm)	n X m-l	b	c		
40	18	35	4XM4-12	4XØ14	30	0.1	YSKM 20X1
	18	35	4XM4-12	4XØ14	30	0.1	YSKM 20X1.5
45	20	40	4XM4-14	4XØ15	35	0.13	YSKM 25X1.5
48	20	45	4 X M4-14	4XØ15	39	0.14	YSKM 30X1.5
53	22	50	4XM4-16	4XØ15	44	0.18	YSKM 35X1.5
58	22	55	4XM4-16	4XØ15	49	0.2	YSKM 40X1.5
68	22	63	4 XM4-16	4XØ16	57	0.28	YSKM 45X1.5
70	25	66	6 X M4-18	6XØ16	60	0.31	YSKM 50X1.5
75	25	71	6 XM4-18	6XØ16	65	0.34	YSKM 55X2
84	26	79	6 X M5-20	6XØ16	72	0.45	YSKM 60X2
88	28	84	6 X M5-20	6XØ16	77	0.53	YSKM 65X2
95	28	89	6 X M5-20	6XØ17	82	0.6	YSKM 70X2
100	28	94	6 X M5-20	6XØ17	87	0.66	YSKM 75X2
110	32	103	6 X M6-22	6XØ18	95	0.98	YSKM 80X2
115	32	108	6 X M6-22	6XØ18	100	0.98	YSKM 85X2
120	32	113	6 X M6-22	6XØ18	105	1.07	YSKM 90X2
125	32	118	6 X M6-22	6XØ18	110	1.1	YSKM 95X2
130	32	123	6 X M6-22	6XØ18	115	1.18	YSKM 100X2
140	32	133	6 X M6-22	6XØ18	125	1.24	YSKM 110X2
155	36	146	6 X M4-25	6XØ18	136	1.87	YSKM 120X2

* El peso es correcto
 * The weight is correct

Introducción

Los suministros de los productos presentes en este documento están regulados por las siguientes condiciones generales de venta. Se hará necesario un acuerdo previo escrito con el proveedor en para ulteriores y eventuales cláusulas y/o condiciones particulares requeridas por los clientes. Se considerarán inaceptables todas las cláusulas y/o condiciones contractuales en contraste con lo expuesto en las presentes condiciones de venta.

1) Ofertas y órdenes

Las ofertas mantienen una validez de 30 días a contar desde la fecha de comunicación al cliente. Transcurrido dicho lapso sin haber recibido la orden, el proveedor tendrá la facultad de aceptar o rechazar la orden tardía. Todas las órdenes deberán indicar siempre la tipología del producto, la cantidad y la fecha de entrega requerida. El proveedor se reserva el derecho de suministrar eventualmente otros productos con las mismas características merceológicas que las solicitadas.

Las órdenes resultan vinculantes para el cliente, incluso cuando no están formuladas por escrito. El proveedor tendrá la misma obligación en el momento del envío de la confirmación de orden de compra (excluidas las excepciones a los puntos dos y cinco).

2) Precios

Los precios válidos de referencia son los indicados en la oferta y/o en la aceptación de la orden y se refieren sólo a productos estándares. Los precios relativos a tipologías especiales de producto y/o no estándares o bien bajo específicos requerimientos del cliente, se acordarán, en cada específica instancia, entre las partes. El proveedor se reserva el derecho, por exigencias productivas y/o de suministro, de suministrar una cantidad de producto con una variación equivalente al $\pm 15\%$ respecto a la cantidad acordada con el cliente. Si durante el suministro, se verifican aumentos, causados por variaciones como por ejemplo: aumento de las materias primas, del coste de la mano de obra, del coste de los transportes, de los impuestos y tributos, como así también otros aumentos que impliquen aumentos de los costes del producto para el proveedor, este último podrá, a su entero juicio, adecuar los precios, comunicando dicho aumento al cliente. Las cotizaciones de los productos, se considerarán siempre franco la sede del proveedor, estando excluidos siempre de dicha cotización el embalaje y el IVA.

3) Entrega

La entrega se considerará finalizada y ultimada en el momento en el cual los productos se pongan a disposición del cliente en el banco, en la sede del proveedor o en el momento de la entrega al transportista. Si el cliente no ha dado precisas instrucciones sobre las modalidades de expedición de los productos o no los ha retirado tempestivamente, el proveedor podrá conservarlos en su propia sede; los riesgos y peligros y los respectivos gastos estarán a cargo del cliente y el proveedor no tendrá responsabilidad alguna en lo que se refiere a la conservación o expedición de los productos con medios propios o mediante transportistas.

4) Plazos de entrega

Los plazos de entrega indicados por el proveedor son indicativos y no tienen un carácter esencial ni perentorio. Su incumplimiento no podrá ser considerado como motivo de rescisión del contrato ni dará derecho a ningún tipo de indemnización. El proveedor respetará los plazos acordados en la medida de lo posible, ya que la entrega depende también de terceros. El proveedor podrá rescindir el contrato y/o modificar los plazos de entrega, sin que esto constituya motivo de resarcimiento ni pago de indemnizaciones por eventuales daños que sufrieran los clientes, en los siguientes casos:

- I. Incumplimiento de los pagos y/o deudas por parte del cliente.
- II. Dificultades en fase de suministro de los productos.
- III. Modificaciones a las condiciones contractuales después de la recepción de la orden.
- IV. Casos de fuerza mayor, no imputables a la voluntad del proveedor, como por ejemplo, huelgas de cualquier tipo, calamidades naturales, epidemias, revueltas, tumultos, guerras, bloqueos aduaneros, que puedan afectar al proveedor mismo o a sus fuentes de suministro.
- V. Errores o retardos por parte del cliente en la confirmación de la orden.

Por los hechos expuestos en los puntos I-III-V el proveedor podrá siempre exigir una indemnización al cliente.

Introduction

The supply of the products covered by this document is governed by the following general conditions of sale. Any additional clauses and/or special conditions requested by Customers shall only be valid in case of prior written agreement with the Supplier. All contract clauses and/or conditions in conflict with the terms set out below shall be considered unacceptable.

1) Offers and orders

Offers are valid for 30 days from the date of communication to the Customer. If no order is received within this period, the Supplier shall have the option of accepting or rejecting late orders, at its own discretion. All orders must always state the type of product, the quantity and the delivery date required. The Supplier reserves the right to supply different products with the same characteristics as those ordered. Orders are binding on the Customer even if not in writing. Orders shall also be binding on the Supplier once the confirmation of order has been dispatched (with the exceptions in points two and five below).

2) Prices

The valid reference prices are those stated in the offer and/or the order acceptance, and refer to standard products only. The prices relating to special and/or nonstandard product types, or to specific requests from the Customer, shall be agreed between the parties for each order on a one-off basis. Depending on production and/or procurement requirements, the Supplier reserves the right to supply a quantity of product with variation of $\pm 15\%$ from the quantity agreed with the Customer. Over a series of shipments, if increases occur due to variations such as increases in raw material costs, in the cost of labour, freight costs, taxes and duties, or any other increases which lead to increases in the cost of the product for the Supplier, the latter may adjust the prices accordingly, at its own absolute discretion, informing the Customer of the amount of any such increase. Quotations for products are ex-works Supplier's factory, not including packaging or VAT.

3) Delivery

Delivery is considered to have taken place when the products are placed on the Customer's disposal on the counter on the Supplier's premises, or on consignment to the carrier/forwarding agent. If the Customer has not given clear instructions concerning the procedures for shipment of the products, or has not arranged for their prompt collection, the Supplier may store them on its own premises, at the Customer's risk and expense, without any responsibility for their conservation, or may ship them using its own vehicles or carriers of its choice.

4) Delivery terms

The delivery terms stated by the Supplier are guideline and not binding. In no case shall failure to meet them constitute grounds for termination of the contract and/or for compensation for any damage of any kind. Delivery terms shall be complied with as far as possible, since delivery depends on third parties over which the Supplier has no control. The Supplier may terminate the contract and/or modify the delivery terms, without this constituting grounds for compensation and/or payment of damages for any costs or losses incurred by the Customer, in the following cases:

- I. Failure to meet payment terms and/or outstanding debts on the part of the Customer.
- II. Difficulty in procurement of the products.
- III. Modifications of the contract conditions after receipt of the order.
- IV. Circumstances of force majeure, beyond the Supplier's control, such as, for example, strikes of various kinds, natural disasters, epidemics, uprisings, riots, wars or customs blockades which may affect the Supplier itself or its sources of supply.
- V. Inaccuracies or delays on the part of the Customer in confirming the order.

In the circumstances listed in points I-III-V, the Supplier may request compensation from the Customer.

5) Expediciones

Las expediciones estarán siempre a cargo de los clientes, como así también los riesgos y peligros inherentes a la misma, incluso en los casos de expediciones franco domicilio del cliente. En el caso de eventuales adulteraciones o falta de productos imputables al transportista, el cliente tendrá la obligación de presentar un reclamo directamente al transportista. El proveedor podrá aceptar reclamos por eventuales diferencias, cualitativas y cuantitativas de los productos sólo si el cliente efectúa dichos reclamos por escrito dentro de los ocho días, a contar desde la fecha de recepción de los productos, so pena de caducidad de todo derecho de reclamo más allá de dicho plazo. Si el cliente no da instrucciones detalladas, no podrá imputarse ninguna responsabilidad al proveedor por la elección de los medios de transporte, en lo que se refiere a las tarifas aplicadas por los transportistas. Además, si no subsiste un acuerdo entre las partes, los gastos de expedición estarán siempre a cargo del cliente. En el caso que los gastos de transporte estén a cargo del proveedor, incluso parcialmente, el mismo podrá elegir los medios de transporte más económicos, a su entero juicio. Ulteriores recargos y costes adicionales de transporte estarán exclusivamente a cargo del cliente. En caso de eventuales errores de entrega causados por el cliente, con la consecuente devolución de los productos, el proveedor tendrá el derecho de cargar al cliente los eventuales gastos de expedición y el 15% del precio de los productos.

6) Pagos

El cliente no podrá suspender ni retardar los pagos de las mercancías por ningún motivo. Dichos pagos se deberán efectuar al domicilio del proveedor, como se indica en los documentos que acompañan la expedición de los productos. No se considerarán válidos los pagos efectuados en lugares diversos, salvo en los casos en los cuales existan acuerdos previos con el proveedor en este sentido.

Una vez transcurridos los plazos indicados, el proveedor tendrá derecho a exigir el pago, además de la suma correspondiente al precio de la mercancía, de los intereses de demora, según Euribor más un 3%, con el derecho además de iniciar las pertinentes acciones legales contra el cliente moroso.

El proveedor tiene la facultad de suspender transitoriamente la fabricación o el suministro de los productos aún en fase de orden; además podrá anular la parte residual de la orden misma, comunicándolo al cliente, el cual no tendrá derecho a ningún tipo de indemnización. El proveedor tendrá el derecho de exigir el pago de las sumas adeudadas por las entregas ya efectuadas. Eventuales reclamos inherentes a productos en curso de fabricación, listos para su expedición o ya en poder del cliente, no liberarán el cliente de sus obligaciones, debiendo el mismo por lo tanto efectuar los pagos acordados y en las fechas estipuladas.

7) Garantía

La garantía tiene una validez de un año a contar desde la fecha de la entrega de los productos; la misma se circunscribe exclusivamente a la reparación o sustitución gratuita de las piezas reconocidas como no conformes respecto a las especificaciones expuestas en los catálogos técnicos.

La responsabilidad de la garantía del proveedor decae para los productos que han sufrido adulteraciones, esfuerzos impropios de servicio, lubricaciones o reparaciones erróneas o bien errores en fase de montaje, como así también en todos los casos de problemas vinculados a una utilización impropia por parte del cliente y por lo tanto no imputables al proveedor. El cliente además tiene la obligación de avisar al proveedor sobre eventuales defectos, vicios o no conformidades de los productos dentro de los ocho días de la recepción de los mismos (en forma escrita), so pena, en caso contrario, de caducidad de la garantía. No se aceptarán reclamos una vez transcurridos dichos plazos.

Los reclamos no justifican la anulación ni la reducción de los órdenes del cliente, ni dan lugar a indemnizaciones y/o resarcimientos a cargo del proveedor. No se aceptan devoluciones de productos sin una previa autorización del proveedor. No se aceptan devoluciones de suministros, en el caso de productos que se envíen no íntegros o adulterados o bien contruidos, elaborados y/o modificados por parte del cliente. El material no conforme se deberá enviar, previa autorización del proveedor, libre de todo gasto (franco destino). En el documento de envío se deberán exponer los datos del DDT o la respectiva factura de venta (Fecha y n° - obligatorio por ley). El proveedor no se asume ninguna responsabilidad por incidentes que puedan verificarse en la utilización de sus productos.

5) Shipments

Shipments are always made on the Customer's behalf and therefore at its risk, even in case of delivery "freight prepaid". In case of tampering or missing items for which the carrier/forwarding agent is specifically to blame, the Customer shall be responsible for placing a claim directly with the carrier/forwarding agent. The Supplier will only be able to accept claims for any differences in the quality or quantity of the products if submitted by the Customer, in writing within eight days after the date of receipt of the products; otherwise, all claims shall become null and void. In the absence of detailed instructions from the Customer, the Supplier shall not be responsible for the choice of means of transport or for the rates charged by the carriers/forwarding agents. Moreover, in the absence of agreement between the parties, the shipment expenses shall be payable by the Customer. If even just a part of the freight costs is to be met by the Supplier, the latter shall be permitted to make use of the most economical means of transport, at its own absolute discretion. Any additional freight costs and/or charges shall be solely for the Customer's account. For errors in delivery caused by the Customer which result in return of the products, the Supplier shall be entitled to charge the Customer the shipment expenses, if due, plus 15% of the price of the products.

6) Payment

The Customer shall not be permitted to suspend or delay payments for goods for any reason, and payments must be made to the Supplier's domicile, as stated in the documents which accompany the shipment of the products. Payments made to other places shall not be considered valid unless agreed in advance with the Supplier. Once the specified payment terms have passed, the Supplier shall be entitled to payment, not only of the capital sum due for the price of the goods, but also of interest at the Euribor rate increased by 3%, and retains the right to take legal action against any Customer late with payments.

The Supplier shall be entitled to temporarily suspend the manufacture or supply of any products still on order; it may also cancel the remainder of the order, informing the Customer, which shall not be entitled to compensation of any kind. The Supplier shall be entitled to obtain payment of the sums due to it for the deliveries already made. In case of any disputes concerning products being manufactured, ready for shipment or already in the Customer's possession, the latter shall not be released from its obligations and must pay the amounts due to the Supplier at the date set.

7) Warranty

The warranty is valid for one year from the date of delivery of the products; it is limited solely to the repair or replacement, free of charge, of pieces acknowledged not to comply with the specifications stated in the technical catalogues.

The Supplier's warranty ceases to apply to all products which have been tampered with, operated with overloads, improperly lubricated or repaired, or incorrectly assembled; in other words, for all problems caused by improper use by the Customer, for which the Supplier is not responsible.

The Customer is also obliged to inform the Supplier about any defects, faults or non-conformity of the products within eight days after the date of receipt of the same (in writing); otherwise, the warranty shall become null and void. No claims shall be accepted once the above terms have expired.

Claims shall not constitute grounds for the cancellation or reduction of orders on the part of the Customer, or the payment of damages and/or compensation on the part of the Supplier. No returns of products are accepted unless authorised in advance. No returns are accepted of products which are not intact, have been tampered with, or have been specifically built, processed and/or modified for the Customer. Non-conforming material must be returned, further to the Supplier's authorisation, with all expenses paid (freight prepaid). The return document must contain the details of the original transport document or invoice (date and number - compulsory by law). The Supplier does not accept any responsibility for accidents occurring during the use of its products.

8) Productos especiales y/o según diseños del cliente

El proveedor, cuando acepte órdenes para productos especiales o realizados según particulares requerimientos del cliente, deberá siempre recibir un diseño técnico detallado antes de iniciar la producción de los mismos. Después de haber aceptado la orden y de haber recibido el diseño técnico, el proveedor enviará al cliente una muestra del producto. Una vez que el cliente ha recibido y examinado la muestra deberá enviar una confirmación escrita al proveedor para que el mismo ultime el suministro. En el caso que el cliente, por motivos no imputables al proveedor rechace en modo total o parcial el suministro, el proveedor podrá ejercitar el derecho de cobrar los gastos por la realización de las muestras de productos, como así también por la pérdida de beneficios y por eventuales perjuicios sufridos, en los casos de productos no comercializables. El proveedor se encargará del retiro y la sustitución del material no conforme, cuando el cliente demuestre en modo evidente que las características del producto suministrado no corresponden a las de las muestras entregadas. De todos modos el proveedor no aceptará ninguna ulterior responsabilidad ni el cliente tendrá derecho a indemnizaciones de ningún tipo.

9) Validez y derogaciones de las Condiciones Generales de Venta

Cualquier tipo de derogación o modificación de las condiciones generales de venta aquí expuestas, se deberá acordar entre las partes en forma escrita.

10) Domicilio del Cliente

El domicilio del Cliente será aquel en el cual el cliente tiene su sede legal, a menos que el mismo comunique por escrito otro domicilio. El proveedor por lo tanto efectuará todas las comunicaciones y envíos de productos a dicha sede.

11) Tribunal competente

Para toda eventual controversia entre las partes resultará competente el tribunal donde se encuentra la sede legal del proveedor.

8) Special and/or custom-made products

If the Supplier accepts orders for special products or those made to the Customer's own technical specifications, it must always receive a detailed technical drawing before proceeding with production. After accepting the order and further to consignment of the technical drawing, the Supplier shall send the Customer a sample lot of the product. After viewing the sample lot, the Customer shall send the Supplier written confirmation for production of the entire ordered amount. If, due to circumstances beyond the Supplier's control, the Customer refuses delivery of all or part of the goods, the Supplier shall be entitled to reimbursement of the expenses for production of the sample lot, and for compensation for loss of earnings and for any damages incurred, since these products are not marketable.

The Supplier shall collect and replace non-conforming material if the Customer clearly demonstrates that the characteristics of the product supplied differ from those of the samples consigned, without any liability on the part of the Supplier and with waiver on the part of the Customer of any request for compensation on any grounds.

9) Validity and waivers of the General Conditions of Sale

Any waivers or modifications of the aforesaid general conditions of sale must be agreed between the parties in writing.

10) Customer's Domicile

The Customer shall be domiciled in the place where it has its registered office, unless otherwise notified in writing. The Supplier shall therefore send all communications and shipments of products to the relevant address.

11) Legal jurisdiction

The law court of the Supplier's registered office shall have jurisdiction over all disputes of any kind.

ISB®



©Copyright ISB®

Está prohibida la reproducción, incluso parcial, del contenido de este Catálogo Técnico. No se acepta ningún tipo de responsabilidad en caso de errores u omisiones. Las medidas no son vinculantes. Marca registrada Italia-EU.

The reproduction, even partial, of the contained concerning this Technical Catalogue, is forbidden. Liability for possible errors and/or omissions are not accepted. Sizes are not binding.™ Registered in Italy-EU.



RODAMIENTOS Y COMPONENTES
BEARINGS AND COMPONENTS

1.03.15 ©Copyright **ISB**®



79991012

